

COMe-cTL6 (E2)

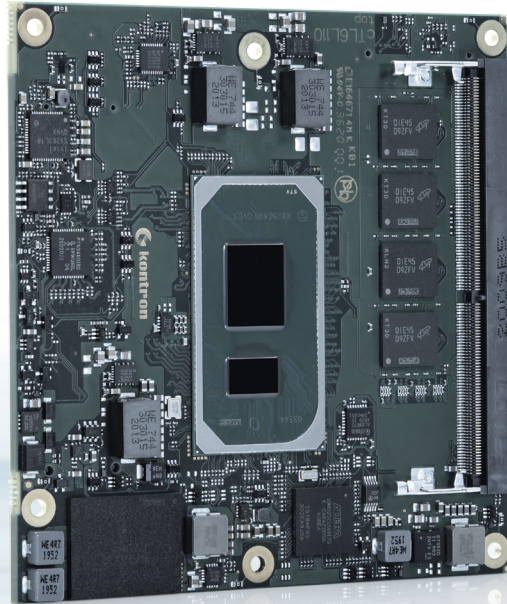

COM Express® Compact Type 6 with 11th Generation Intel® Core™/Celeron® Processors

- ▶ Up to 48 GByte DDR4 memory (16 GByte DDR4 memory down)
- ▶ Up to 2.5 Gb Ethernet with TSN support
- ▶ Optional NVMe SSD onboard
- ▶ Industrial grade versions

POSSIBILITIES START HERE

► TECHNICAL INFORMATION

COMPLIANCE	COM Express® Compact Pin-out Type 6
DIMENSIONS (H x W x D)	95 x 95 mm
CPU	Intel® 11th Generation Core™/ Celeron® family For details see table (CPU variants) given below
CHIPSET	Integrated SoC
MAIN MEMORY	1x DDR4 SO-DIMM up to 32 GByte, 2nd channel DDR4 memory down up to 16 GByte
GRAPHICS CONTROLLER	Intel® Iris®Xe Graphics on i7/i5 processors Intel® UHD Graphics on i3/Celeron® processors
ETHERNET CONTROLLER	Intel® I225LM/I225IT
ETHERNET	Up to 2.5Gb Ethernet with TSN support (depending on SKU)
STORAGE	2x SATA 6Gb/s
FLASH ONBOARD	Up to 1 TByte NVMe SSD (on request)
PCI EXPRESS®	5x PCIe 3.0 (On request: 6x without Ethernet, up to 8x without Ethernet & SATA) 1x4 PCIe 4.0 on PEG Lanes #0-3
DISPLAY	DDI1: DP++, DDI2: DP++, DDI3: DP++, VGA: -, LVDS: Dual Channel 18/24bit
USB	4x USB 3.1 (incl. USB 2.0) + 4x USB 2.0
SERIAL	2x serial interface (RX/TX only)
AUDIO	High Definition Audio interface
OTHER FEATURES	(G)SPI, LPC, SMB, Fast I ² C, Staged Watchdog, RTC
SPECIAL FEATURES	POSCAP capacitors, Trusted Platform Module TPM 2.0
FEATURES ON REQUEST	vPRO (AMT/TXT/AES Support), eDP instead of LVDS, VGA, up to 3x PCIe x1 additional w/o Ethernet & SATA, NVMe SSD, Fail Safe via 2nd SPI Flash
POWER MANAGEMENT	ACPI 6.0
POWER SUPPLY	8.5 V – 20 V Wide Range, Single Supply Power
BIOS	AMI Aptio V
OPERATING SYSTEM	Windows®10, Linux, VxWorks
TEMPERATURE	Commercial temperature: 0 °C to +60 °C operating, -30 °C to +85 °C non-operating Extended temperature: -25 °C to +75 °C operating, -30 °C to +85 °C non-operating Industrial temperature: -40 °C to +85 °C operating, -40 °C to +85 °C non-operating
HUMIDITY	93 % relative Humidity at 40 °C, non-condensing (according to IEC 60068-2-78)

► CPU VARIANTS

	11th GENERATION						
CPU	i7-1185G7E	i5-1145G7E	i3-1115G4E	6305E	i7-1185GRE	i5-1145GRE	i3-1115GRE
CORES	4	4	2	2	4	4	2
FREQUENCY BASE/TURBO	1.8/4.4 GHz	1.5/4.1 GHz	2.2/3.9 GHz	1.8/- GHz	1.8/4.4 GHz	1.5/4.1 GHz	2.2/3.9 GHz
TDP	28/15/12 W	28/15/12 W	28/15/12 W	15 W	28/15/12 W	28/15/12 W	28/15/12 W
CACHE	12 MByte	8 MByte	6 MByte	4 MByte	12 MByte	8 MByte	6 MByte
IBEC	no	no	no	no	yes	yes	yes
TCC/TSN	no	no	no	no	yes	yes	yes

BLOCK DIAGRAM

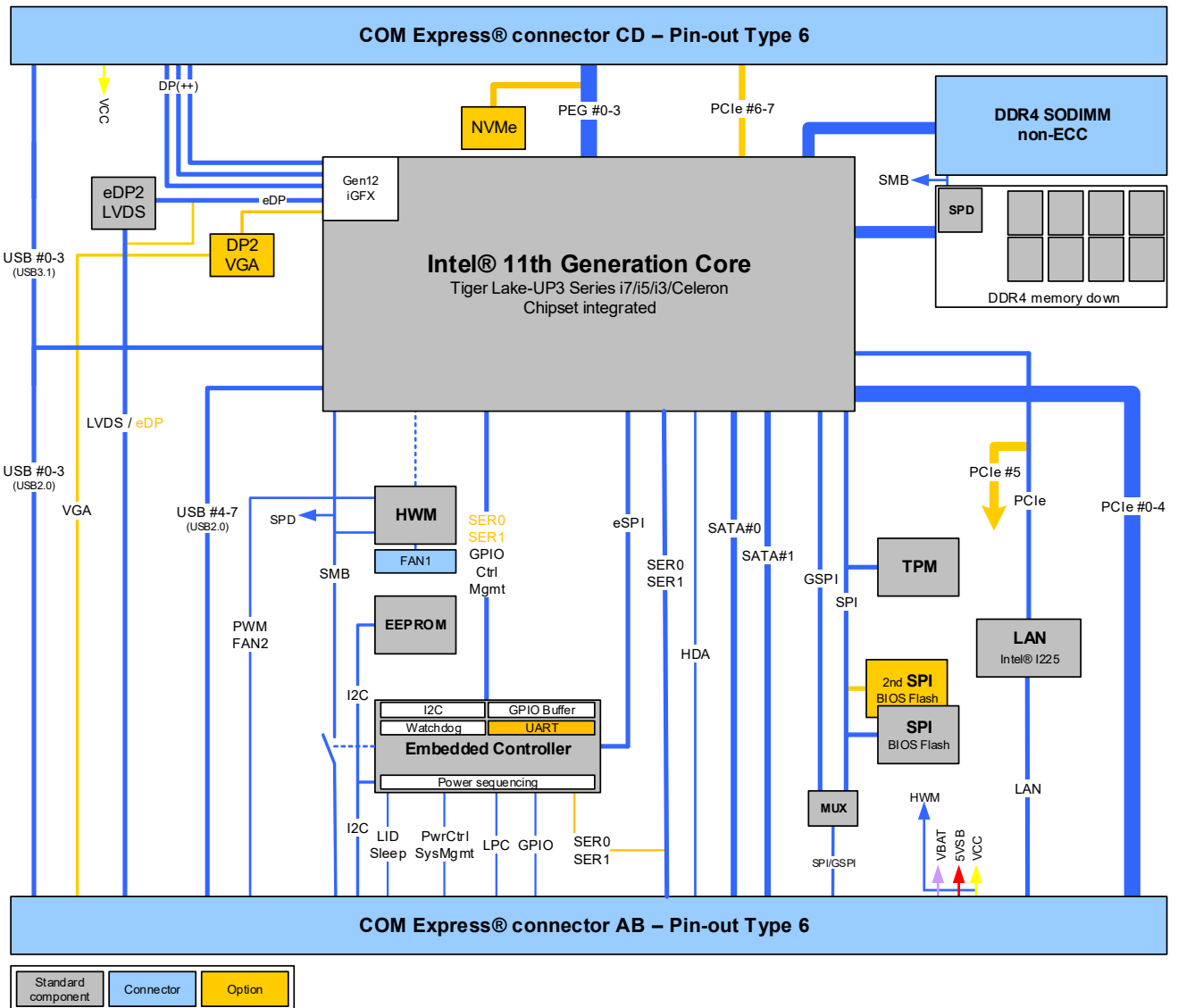

VARIANTS

PART NO.	CPU	PCH	MEM. DOWN	SO-DIMM	FLASH	OP. TEMPERATURE
36030-1610-18-7	i7-1185G7E	integrated	16 GByte	non-ECC	1 TByte	0 °C - 60 °C
36030-1600-18-7	i7-1185G7E	integrated	16 GByte	non-ECC	-	0 °C - 60 °C
36030-0000-18-7	i7-1185G7E	integrated	-	non-ECC	-	0 °C - 60 °C
36030-8000-15-5	i5-1145G7E	integrated	8 GByte	non-ECC	-	0 °C - 60 °C
36030-0000-15-5	i5-1145G7E	integrated	-	non-ECC	-	0 °C - 60 °C
36030-0000-22-3	i3-1115G4E	integrated	-	non-ECC	-	0 °C - 60 °C
36030-0000-18-2	6305E	integrated	-	non-ECC	-	0 °C - 60 °C
36031-1600-18-7	i7-1185GRE	integrated	16 GByte	non-ECC	-	-40 °C - 85 °C
36031-8000-15-5	i5-1145GRE	integrated	8 GByte	non-ECC	-	-40 °C - 85 °C
36031-0000-22-3	i3-1115GRE	integrated	-	non-ECC	-	-40 °C - 85 °C