



377-014
Composite Backshell
for Fiber Optic MIL-DTL-38999 Series III & IV Connectors

D38999
Series III

B

MIL-DTL-38999 series III & IV backshell



How To Order

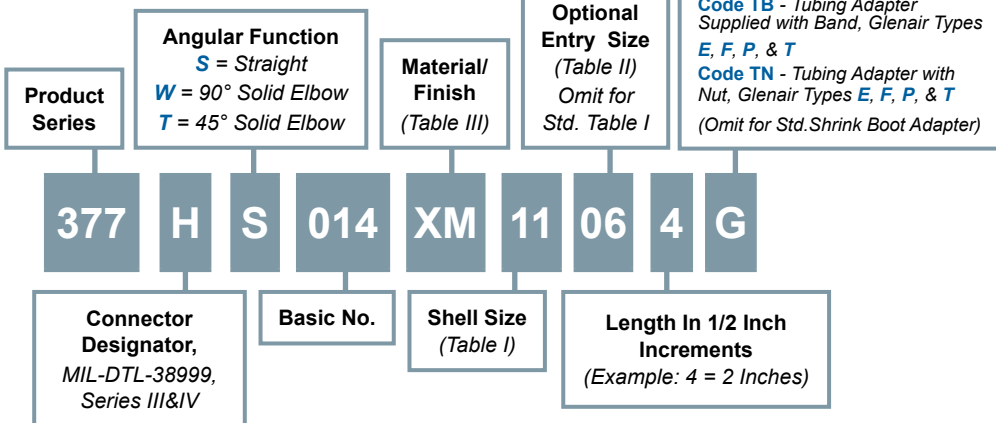

Code G - Gland Nut;
Code T - Tubing Adapter, Glenair Types E, F, P, & T
Code K - Tubing Adapter with Nut, Glenair Peek
Code TB - Tubing Adapter Supplied with Band, Glenair Types E, F, P, & T
Code TN - Tubing Adapter with Nut, Glenair Types E, F, P, & T (Omit for Std. Shrink Boot Adapter)

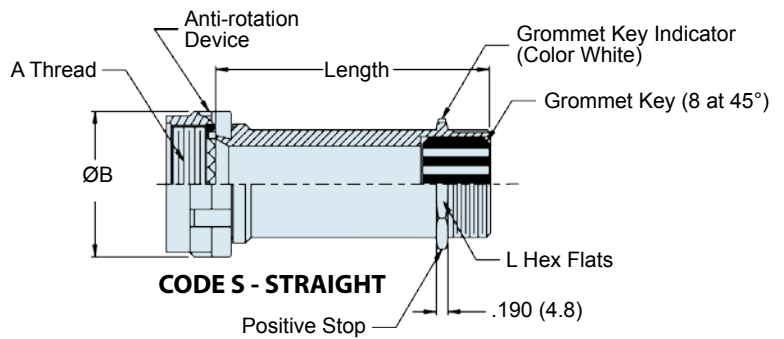
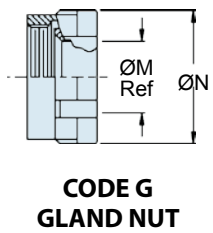
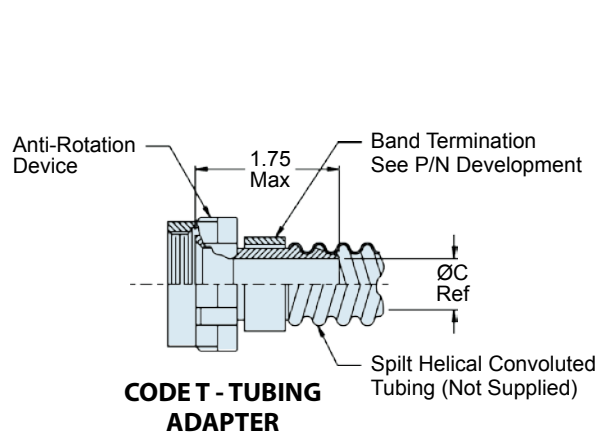

Material and Finish

Adapters, Elbows, Coupling Nut, Nut: Hi-grade engineering thermoplastic/see table III
Grommet, O-Ring: Fluorosilicone
Anti-Rotation Device: Corrosion resistant material

Notes

Glenair 600 Series Backshell assembly tools are recommended for assembly and installation.
Standard minimum length: 1.5 inches, for shorter length consult factory.
For Sealing Plugs, see Glenair drawing 687-142.

377-014
Composite Backshell
 for Fiber Optic MIL-DTL-38999 Series III & IV Connectors



MIL-DTL-38999
 Series III Type

B

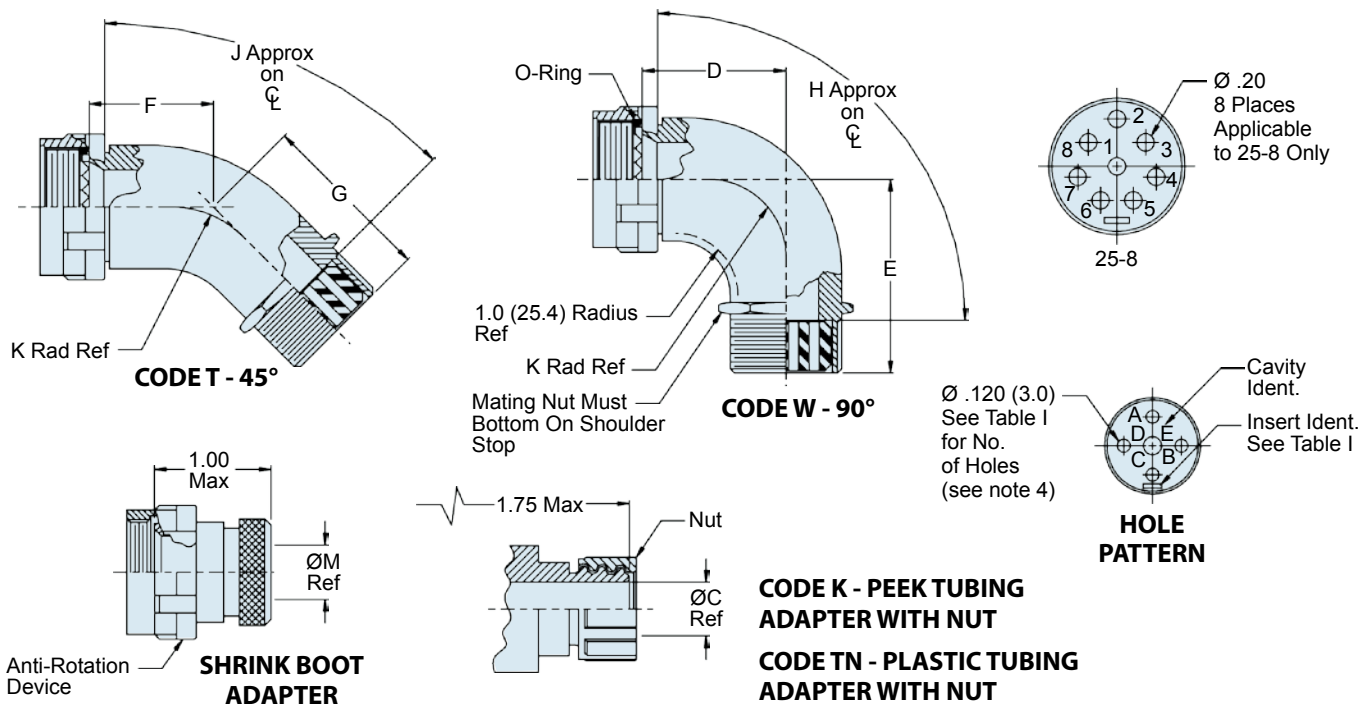

Table I

Shell Size	A Thread	ϕ B Max	Std. Conduit Size Ref.	D Max	E Max	F Max	G Max	H Approx	J Approx	K Ref	L Hex	ϕ M Ref	ϕ N Max	Insert Arrangement	No. Of Holes
11	M15 X 1 - 6H	1.00	3/8	1.78	1.93	1.33	1.56	2.23	2.09	1.20	.938	.32	1.38	11-2	2
13	M18 X 1 - 6H	1.12	7/16	1.84	1.98	1.39	1.62	2.28	2.21	1.26	.938	.54	1.38	13-4	4
15	M22 X 1 - 6H	1.25	1/2	1.90	2.08	1.45	1.68	2.45	2.33	1.32	.938	.54	1.38	15-5	5
17	M25 X 1 - 6H	1.38	5/8	1.97	2.14	1.51	1.74	2.47	2.44	1.38	1.250	.76	1.56	17-8	8
19	M28 X 1 - 6H	1.50	3/4	2.11	2.18	1.54	1.77	2.54	2.50	1.43	1.250	.76	1.56	19-11	11
21	M31 X 1 - 6H	1.62	7/8	2.07	2.25	1.61	1.84	2.64	2.64	1.49	1.500	1.00	1.81	21-16	16
23	M34 X 1 - 6H	1.75	1	2.14	2.31	1.67	1.89	2.76	2.75	1.55	1.500	1.00	1.81	23-21	21
25	M37 X 1 - 6H	1.88	1	2.19	2.19	1.73	1.96	2.84	2.87	1.62	1.812	1.27	2.12	25-29	29
25-8	M37 X 1 - 6H	1.88	1 1/4	2.19	2.19	1.73	1.96	2.84	2.87	1.62	1.812	1.27	2.12	25-8	8
25-37	M37 X 1 - 6H	1.88	1 1/4	2.19	2.19	1.73	1.96	2.84	2.87	1.62	1.812	1.27	2.12	25-37	37

Table II

Entry Size	ϕ C Ref Code T & TN	ϕ C Ref Code K	Optional Conduit Size Ref.
03	.188	.188	9/32
04	.236	-	5/32
05	.250	.265	3/8
06	.338	.330	7/16
07	.398	.390	1/2
08	.523	.515	5/8
10	.648	.640	3/4
11	.648	.640	3/4
13	.778	.765	7/8
15	.875	.869	1
17	1.078	1.125	1 1/4

Table III: Material and Finish

Code	Material	Finish Description
-		Dash (-) For No Plating, Amber Color
XB		No Plating - Black Color
XM	Composite	Electroless Nickel
XW		Cadmium Olive Drab Over Electroless Nickel
XMT		Nickel-PTFE, Grey

Refer to Appendix for material/finish details