



3L09-1

SNAP DISC FIXED TEMPERATURE BOARD MOUNT LIMITS

1/2" Automatic reset snap disc thermostats with ranges for all your system needs.

FEATURES

- Proven reliability in a compact, versatile, cost-effective design
- Provides high-speed contact separation

SPECIFICATIONS

Switch ActionSPST Open on Rise
 Electrical RatingsResistive 15A @ 120 VAC, 13A @ 240 VAC,
Inductive 5.8 FLA, 34.8LRA @ 120 VAC; 2.9FLA, 13.0 LRA @ 240 VAC
 Pilot Duty 125 VAC
 Dimensions37"H X 1.32"W X 1.23"L
 Weight 0.2 oz.
 UR/CUR File NumberE19279
 CSA/CUS Certificate Number..... LR77886/LR109556
 VDE Lic. 118631

SNAP DISC FIXED TEMPERATURE BOARD MOUNT LIMITS

APPLICATIONS	CUT-IN	CUT-OUT	SWITCH ACTION	TOD TYPE	TOD STYLE	LENGTH (IN)	MODEL NUMBER	ITEM NUMBER
Snap Disc Board Mount Limit - Automatic Reset	100°F (38°C)	140°F (60°C)	Open on Rise	36T01B2	612700	1.87	3L09-1	03L09 001S1
	130°F (54°C)	170°F (77°C)	Open on Rise	36T01B2	612708	1.87	3L09-2	03L09 002S1
	110°F (43°C)	140°F (60°C)	Open on Rise	36T01B3	612701	3.12	3L09-3	03L09 003S1
	130°F (54°C)	150°F (66°C)	Open on Rise	36T01B3	612703	3.12	3L09-4	03L09 004S1
	140°F (60°C)	160°F (71°C)	Open on Rise	36T01B3	612706	3.12	3L09-5	03L09 005S1
	130°F (54°C)	170°F (77°C)	Open on Rise	36T01B3	612710	3.12	3L09-6	03L09 006S1
	145°F (63°C)	175°F (79°C)	Open on Rise	36T01B3	612711	3.12	3L09-7	03L09 007S1
	140°F (60°C)	180°F (82°C)	Open on Rise	36T01B3	612714	3.12	3L09-8	03L09 008S1
	170°F (77°C)	190°F (88°C)	Open on Rise	36T01B3	612715	3.12	3L09-9	03L09 009S1
	160°F (71°C)	200°F (93°C)	Open on Rise	36T01B3	612718	3.12	3L09-10	03L09 010S1
	170°F (77°C)	210°F (99°C)	Open on Rise	36T01B3	612719	3.12	3L09-11	03L09 011S1
	180°F (82°C)	220°F (104°C)	Open on Rise	36T01B3	612722	3.12	3L09-12	03L09 012S1
	210°F (99°C)	240°F (116°C)	Open on Rise	36T01B3	612723	3.12	3L09-13	03L09 013S1
	210°F (99°C)	250°F (121°C)	Open on Rise	36T01B3	612725	3.12	3L09-14	03L09 014S1
	230°F (110°C)	260°F (127°C)	Open on Rise	36T01B3	612727	3.12	3L09-15	03L09 015S1
	130°F (54°C)	150°F (66°C)	Open on Rise	36T01B3	612704	3.12	3L09-16	03L09 016S1
	225°F (107°C)	250°F (121°C)	Open on Rise	36T01B3	612726	3.12	3L09-17	03L09 017S1
	125°F (62°C)	155°F (68°C)	Open on Rise	36T01B3	612705	7.12	3L09-18	03L09 018S1
	145°F (63°C)	175°F (79°C)	Open on Rise	36T01B3	612712	7.12	3L09-19	03L09 019S1
	210°F (99°C)	240°F (116°C)	Open on Rise	36T01B3	612724	7.12	3L09-20	03L09 020S1
	140°F (60°C)	160°F (71°C)	Open on Rise	36T01B3	612707	3.12	3L09-22	03L09 022S1
	150°F (66°C)	170°F (77°C)	Open on Rise	36T01B3	612709	3.12	3L09-23	03L09 023S1
	170°F (77°C)	190°F (88°C)	Open on Rise	36T01B3	612716	3.12	3L09-24	03L09 024S1
	180°F (82°C)	200°F (93°C)	Open on Rise	36T01B3	612717	3.12	3L09-25	03L09 025S1
	160°F (71°C)	180°F (82°C)	Open on Rise	36T01B3	612713	1.87	3L09-26	03L09 026S1
	200°F (93°C)	220°F (104°C)	Open on Rise	36T01B3	612721	1.87	3L09-27	03L09 027S1
	180°F (82°C)	210°F (99°C)	Open on Rise	36T01B3	612720	3.12	3L09-28	03L09 028S1

FIG. 1

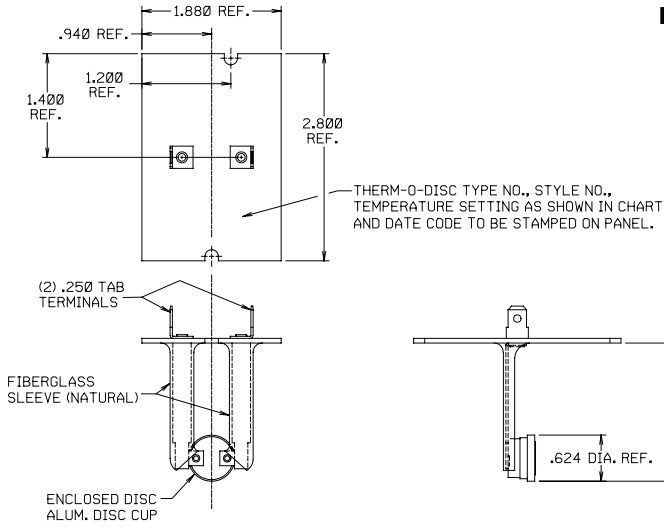

MODEL NUMBER	TEMP. SETTING ON PANEL	OPEN TEMP.	CLOSE TEMP.
3L09-1	L140-40	140°F±5°	100°F±8°
3L09-2	L170-40	170°F±5°	130°F±8°

CONSTRUCTION "A"

FIG. 2

CONSTRUCTION "B"

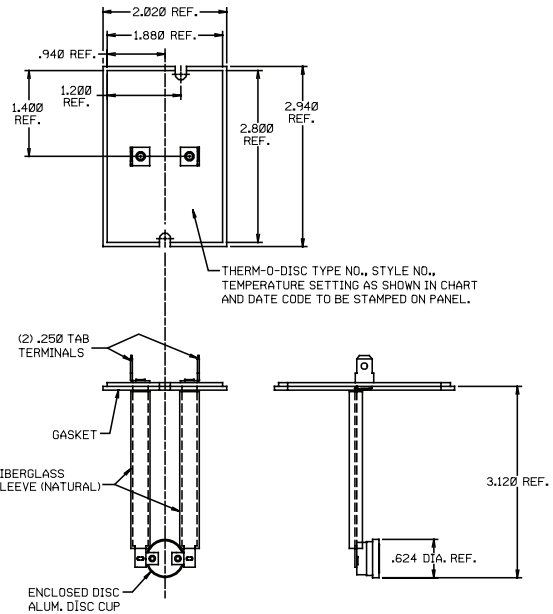
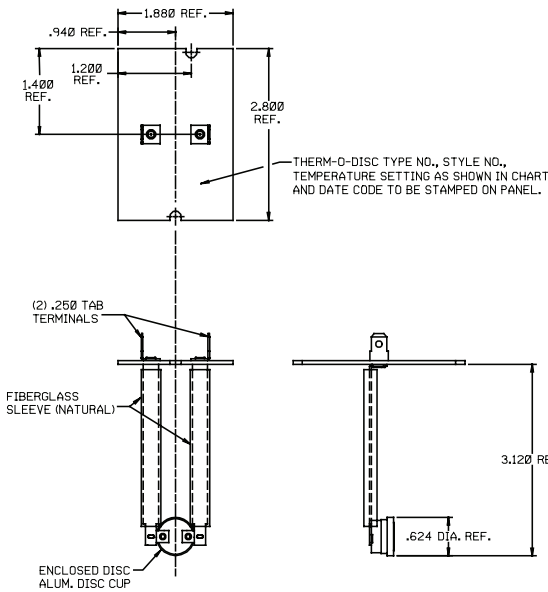

CONSTRUCTION "C"

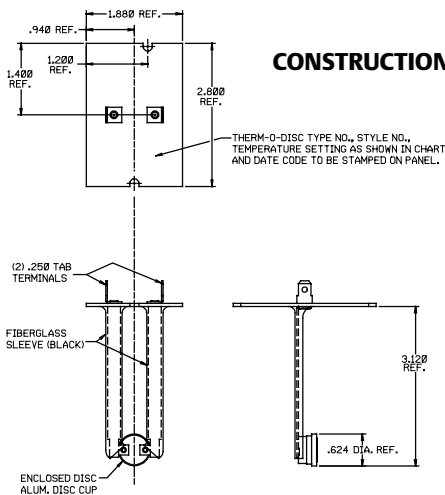

MODEL NUMBER	CONSTRUCTION	TEMP. SETTING ON PANEL	OPEN TEMP.	CLOSE TEMP.
3L09-3	A	L140-30F	140°F±5°	110°F±8°
3L09-4	C	L150-20F	150°F±5°	130°F±8°
3L09-5	C	L160-20F	160°F±5°	140°F±8°
3L09-6	B	L170-40F	170°F±5°	130°F±8°
3L09-7	A	L175-30F	175°F±5°	145°F±8°
3L09-8	B	L180-40F	180°F±6°	140°F±9°
3L09-9	C	L190-20F	190°F±5°	170°F±8°
3L09-10	B	L200-40F	200°F±6°	160°F±9°
3L09-11	B	L210-40F	210°F±6°	170°F±9°
3L09-12	B	L220-40F	220°F±6°	180°F±9°
3L09-13	A	L240-30F	240°F±6°	210°F±10°
3L09-14	B	L250-40F	250°F±7°	210°F±11°
3L09-15	A	L260-30F	260°F±6°	230°F±10°

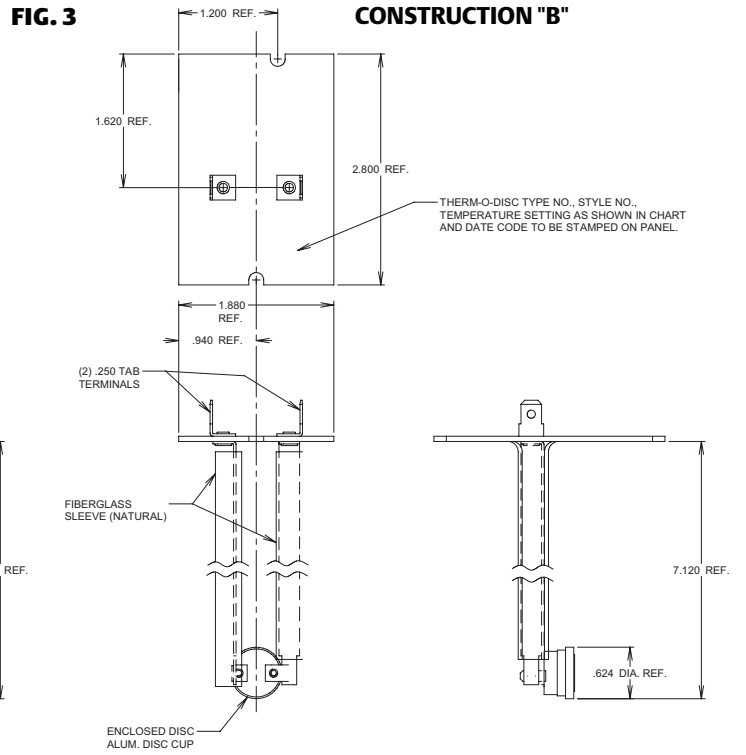
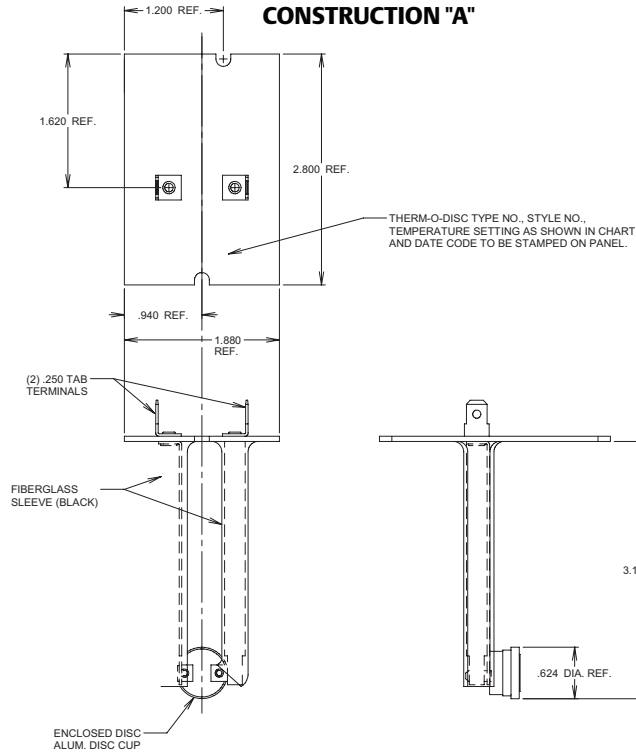

MODEL NUMBER	CONSTRUCTION	TEMP. SETTING ON PANEL	OPEN TEMP.	CLOSE TEMP.
3L09-16	A	L150-20F	150°F±5°	130°F±8°
3L09-17	A	L250-25F	250°F±6°	225°F±9°
3L09-18	B	L155-30F	155°F±5°	125°F±8°
3L09-19	B	L175-30F	175°F±5°	145°F±8°
3L09-20	B	L240-30F	240°F±6°	210°F±10°

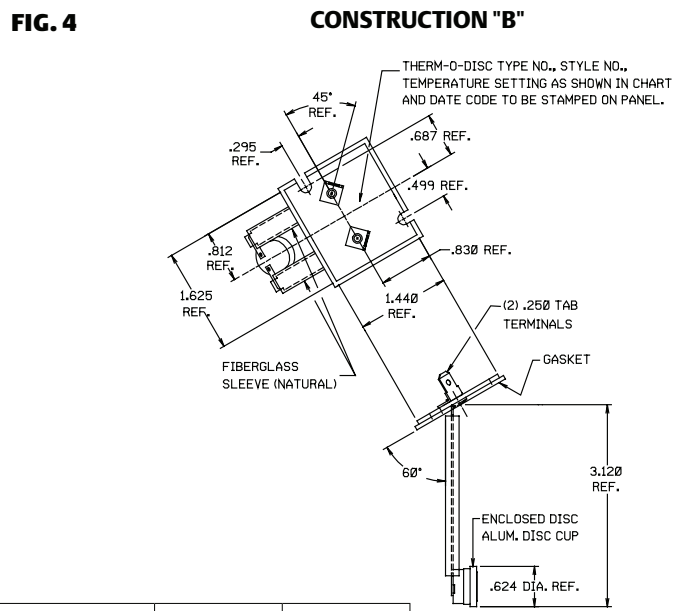
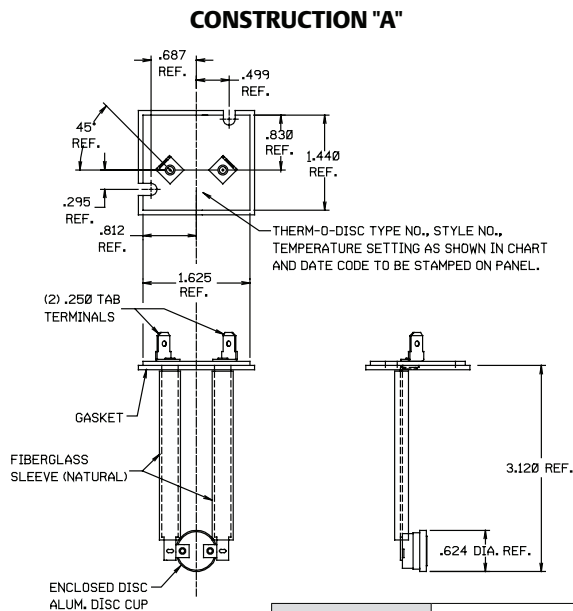

MODEL NUMBER	CONSTRUCTION	TEMP. SETTING ON PANEL	OPEN TEMP.	CLOSE TEMP.
3L09-22	A	L160-20F	160°F±5°	140°F±8°
3L09-23	A	L170-20F	170°F±5°	150°F±8°
3L09-24	B	L190-20F	190°F±5°	170°F±8°
3L09-25	B	L200-20F	200°F±5°	180°F±8°