

| REVISIONS |                 |          |          |
|-----------|-----------------|----------|----------|
| REV.      | DESCRIPTION     | DATE     | APPROVED |
| A         | INITIAL RELEASE | 03/02/10 | M.J.     |

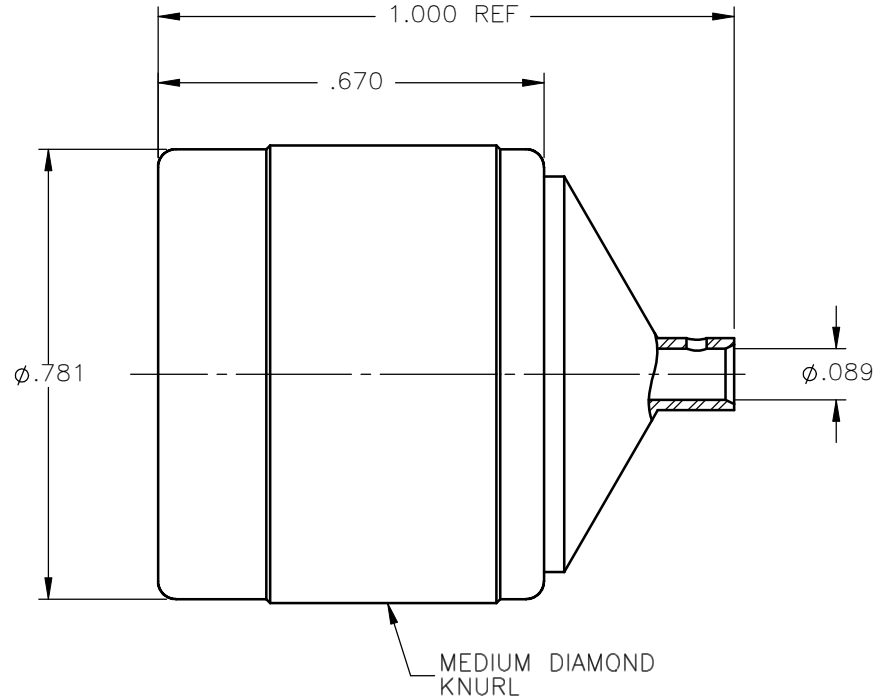

NOTES:

MATERIALS:

1. BODY & COUPLING NUT = STAINLESS STEEL PER ASTM A582, ALLOY 303, CONDITION "A".
2. INSULATOR = VIRGIN WHITE TEFLON PER ASTM D1710, GRADE 1, TYPE I, CLASS "B".
3. CONTACT & CONTACT SLEEVE = BERYLLIUM COPPER PER ASTM B196, ALLOY C17300, TEMPER TD04.
4. GASKET = DOW CORNING SILASTIC 250 SILICONE RUBBER 45-55 DUROMETER.
5. WASHER = PHOSPHOR BRONZE PER ASTM B139, COPPER ALLOY C53400, TEMPER H04.

FINISHES:

1. BODY = GOLD PLATE PER MIL-G-45204, TYPE II, CLASS 0, GRADE C, OVER .000050 TO .00010 STRESS FREE NICKEL PER QQ-N-290.
2. COUPLING NUT = PASSIVATE PER QQ-P-35, TYPE VI.
3. CONTACT & CONTACT SLEEVE = GOLD PLATE PER MIL-G-45204, TYPE II, CLASS 1, GRADE C, OVER .00010 TO .00020 STRESS FREE SULFAMATE NICKEL PER QQ-N-290.

Property of Radiall Incorporated  
 This document cannot be reproduced or communicated to a third party without prior written permission of RADIALL Incorporated.

|   |                                 |                |  |  |  |                |
|---|---------------------------------|----------------|--|--|--|----------------|
| UNLESS OTHERWISE SPECIFIED DIMENSIONS ARE IN INCHES TOLERANCES ON | DWN: M.J.                       | DATE: 03/02/10 |  <b>APPLIED ENGINEERING PRODUCTS</b><br>104 John W. Murphy Dr.<br>New Haven, CT 06513<br><b>a RADIALL company</b> | <b>TYPE "N" STRAIGHT PLUG</b><br><b>DIRECT SOLDER TYPE</b><br><b>FOR .086 S/R &amp; SIMILAR CABLES</b> |  |                |
|   | DECIMAL                         | ANGLE          |  |  |  | CHKD: D.N.     |
|   |                                 | APVD: J.M.     |  |  |  | DATE: 03/02/10 |
| REFERENCE:  | MATERIALS & FINISHES: SEE NOTES |                |  |  |  | SIZE: A        |
| ORIGINATED: M.J.<br>DATE: 03/02/10                                |                                 |                | SCALE: 3:1   | THIRD ANGLE PROJECTION   |  | SHEET 1 OF 1   |

4000-1563-010