

REVISIONS			
REV.	DESCRIPTION	DATE	APPROVED
A	INITIAL RELEASE	12/05/14	N.D.

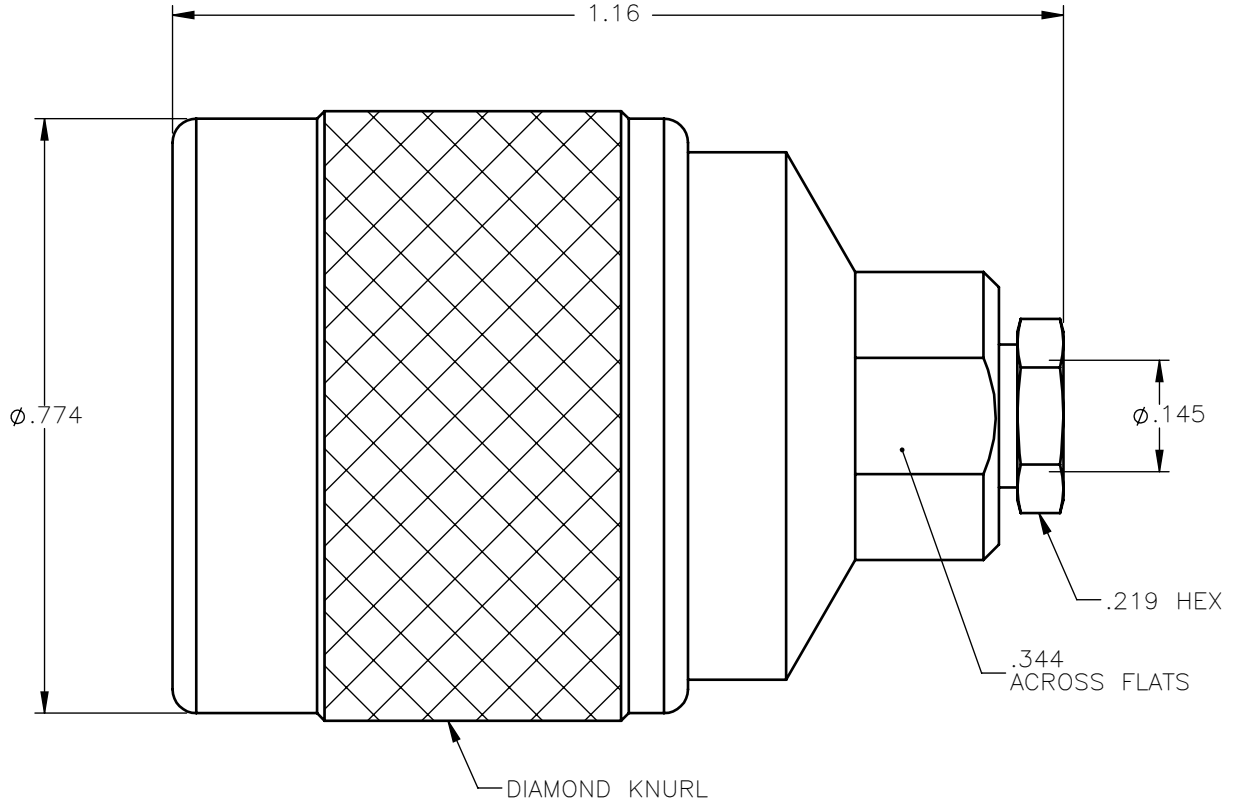



NOTES:

MATERIALS:

1. INSULATORS = VIRGIN WHITE TEFLON PER ASTM D1710, GRADE 1, TYPE I, CLASS "B".
2. WASHER = PHOSPHOR BRONZE PER ASTM B139, COPPER ALLOY C53400, TEMPER H04.
3. GASKET = DOW CORNING SILASTIC 250, SILICONE RUBBER 45-55 DUROMETER.
4. ALL OTHER METAL PARTS = BRASS PER ASTM B16, ALLOY C36000, TEMPER H02.

FINISHES:

1. CENTER CONTACT = GOLD PLATE PER ASTM B488-01, TYPE II, 50 μ in MIN, GRADE C, OVER 100 TO 200 μ in STRESS FREE SULFAMATE NICKEL PER QQ-N-290.
2. SOLDER FITTING = GOLD PLATE PER ASTM B488-01, TYPE II, 30 μ in MIN, GRADE C OVER 100 TO 200 μ in COPPER STRIKE PER MIL-C-14550.
3. ALL OTHER METAL PARTS = NICKEL PLATE PER QQ-N-290, 50 μ in MIN, GRADE G, EXCEPT 100 TO 200 μ in THICK OVER 50 TO 100 μ in THICK COPPER PER MIL-C-14550.

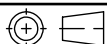
UNLESS OTHERWISE SPECIFIED DIMENSIONS ARE IN INCHES TOLERANCES ON	DWN:	DATE	 Property of Radiall This document cannot be reproduced or communicated to a third party without prior written permission of RADIALL.	
	N.D.	12/05/14		
DECIMAL	ANGLE	CHKD:	DATE	TYPE "N" STRAIGHT PLUG SOLDER CLAMP FOR .141 S/R & SIMILAR CABLES
		D.N.	12/05/14	
		APVD:	DATE	
		J.M.	12/05/14	SIZE A FSCM NO. 19505 DWG NO. 4000-7041-009 REV A
REFERENCE:	MATERIALS & FINISHES:	SEE NOTES		SCALE 4:1 THIRD ANGLE PROJECTION 
ORIGINATED: N.D. DATE: 12/05/14				SHEET 1 OF 1

4000-7041-009