

Description

Single pole, miniaturised thermal circuit breaker with trip-free mechanism and push/pull on/off manual actuation (M-type TO CBE to EN 60934). Threadneck panel mounted, temperature-compensated, with optional auxiliary contacts. Fully approved for commercial aircraft and similar requirements.

Various dummies are available without protective function, allowing connection of pre-installed wiring without loads.

US patent number: US 6,490,141 B2 (4120-G4 moulded threadneck)

Typical applications

Extra low voltage wiring systems on all types of vehicles for land, sea and air.

Ordering information

Type No.

4120 single pole, with temperature compensation

Mounting

G threadneck panel mounting

Threadneck design

1 M12x1x6.3 (aluminium)

2 7/16-32 UNx6.3 (aluminium)

Number of poles

1 1-pole, thermally protected

Hardware for threadneck

0 without hardware

1 hex nut M12x1, corrugated washer 12/15, fitted

3 hex nut M12x1 (aluminium), serrated lock washer 12.1/17.2, bulk shipped

4 hex nut 7/16-32UN (aluminium), serrated lock washer 11.3/14.9, fitted

Terminal design (main terminals)

K1 screw terminals with metric thread K14 (M4)

J1 screw terminals with inch thread J14 (8-32UNC-2B)

J2 screw terminals with inch thread J17 (8-32UNC-2B)

J3 screw terminals with inch thread J25 (6-32UNC-2B)

P1 blade terminals 6.3x0.8, DIN 46244, silver-plated

Characteristic curve

M1 thermal, 1.15 - 1.4 I_N

Terminal screws

A Phillips screw M4x6, fitted

B Phillips screw 8-32UNC-2Ax6, fitted

C Phillips screw 6-32UNC-2Ax6 (MS 51957-26)

K hex screw with Phillips head 8-32UNC-3Ax7.6, fitted

M hex screw with Phillips head 8-32UNC-3Ax7.6, bulk shipped

Z without terminal hardware

Terminal washers

0 without lock washer

1 wave washer A4, fitted

2 lock washer 4.3, fitted

4 lock washer 3.7 (MS 35338-136)

5 lock washer 4.3/9, fitted

6 lock washer 4.3/9, bulk shipped

Auxiliary contact

S0 without auxiliary contact

S1 with auxiliary contact (connector EN 3155-016M2018) (NC)

S5 with polarized auxiliary contact (NC)

Barrier

Z without barrier

Colour of the push button

G green to EN (e. g. 2 1/2)

N black to EN (e. g. 2 1/2)

Current ratings

1...25 A

4120 - G 1 1 1 - 1 - K1 M1 - A 1 S0 Z N - 10 A ordering example



4120-...

Technical data

Voltage rating	AC 115 V (300 Hz to 800 Hz); DC 28 V		
Current rating range	1...25 A (0.5 A upon request)		
Auxiliary circuit	1 A, DC 28 V (0.5 A upon request)		
Typical life	20,000 operations mechanical, or 5,000 operations at 1 x I _N		
Ambient temperature	-55°C ...+125°C (-67...+257 °F)		
Insulation co-ordination (IEC 60664 and 60664A)	rated impulse withstand voltage	pollution degree 3	
Dielectric strength (IEC 60664 and 60664A)	test voltage	operating area AC 1,500 V	
	main to aux. circuit	AC 1,500 V	
Insulation resistance	> 100 MΩ (DC 500 V)		
Interrupting capacity I _{cn}	AC 115 V (400 Hz):	1...4 A	1,000 A
		5...25 A	2,000 A
	DC 28 V:	1...25 A	6,000 A
Degree of protection (IEC 60529/DIN 40050)	operating area IP40 terminal area IP00		
Vibration (sinusoidal)	10 g (57-2000 Hz), ± 0.76 mm (5-57 Hz) to ISO 7137, EN 2350 para. 5.3.1		
Vibration	1...2.5 A: 0.04 g ² /Hz ± 1.5 dB; 7.3 g eff 3...20 A: 0.06 g ² /Hz ± 1.5 dB; 9 g eff to ISO 7137, EN 2350 para. 5.3.1		
Acceleration	17 g, to ISO 2669, EN 2350 para. 5.3.3		
Shock	50 g (11 ms), to ISO 7137, EN 2350 para. 5.3.2		
Corrosion	48 hours at 5 % salt mist to ISO 7137, EN 2350 para. 5.4.2		
Humidity	240 hours at 95 % RH, to ISO 7137, EN 2350 para. 5.4.3		
Explosion	to VG 95210, sheet 10		
Altitude	≤ 22,000 m above sea level		
Mass	approx. 20.6 g with terminal screws, without -Si approx. 24.6 g with terminal screws, with -Si		

Preferred types

Preferred types	Standard current ratings (A)								
	1	2	3	5	7.5	10	15	20	25
4120-G214-J1M1-B2S0ZN (MS3320)	x	x	x	x	x	x	x	x	x
4120-G111-K1M1-A1S0ZN (EN 2495/VG93345 T06)	x	x	x	x	x	x	x	x	x

Standard current ratings and typical volt drop values

Current rating (A)	Volt drop (mV)	Current rating (A)	Volt drop (mV)
1	1100	7.5	250
2	550	10	230
2.5	460	15	200
3	440	20	190
4	380	25	190
5	260		

Approvals (configurations)

Authority	Standard	Voltage ratings	Current ratings
UL	UL 1077	DC 50 V	0.5 A...25 A
Bw	VG 95345, part 6	AC 115 V, 400 Hz DC 28 V	1 A...25 A 1 A...25 A
Bw	EN 2495-...U / -...M	AC 115 V, 400 Hz DC 28 V	1 A...25 A 1 A...25 A
Bw	LN 29887	AC 115 V, 400 Hz DC 28 V	5 A...25 A 5 A...25 A
Bw	EN 3773-004	AC 115 V, 400 Hz DC 28 V	1 A...25 A 1 A...25 A
Dep. of the Navy	MS 3320	AC 115 V, 400 Hz DC 28 V	1 A...20 A 1 A...20 A
Airbus	EN 2995-004	AC 115 V, 400 Hz DC 28 V	1 A...25 A 1 A...25 A
Airbus	EN 2995-005	AC 115 V, 400 Hz DC 28 V	1 A...25 A 1 A...25 A

Dimensions 4120-...

4120-G214-J1M1-B2S0ZN (MS 3320)

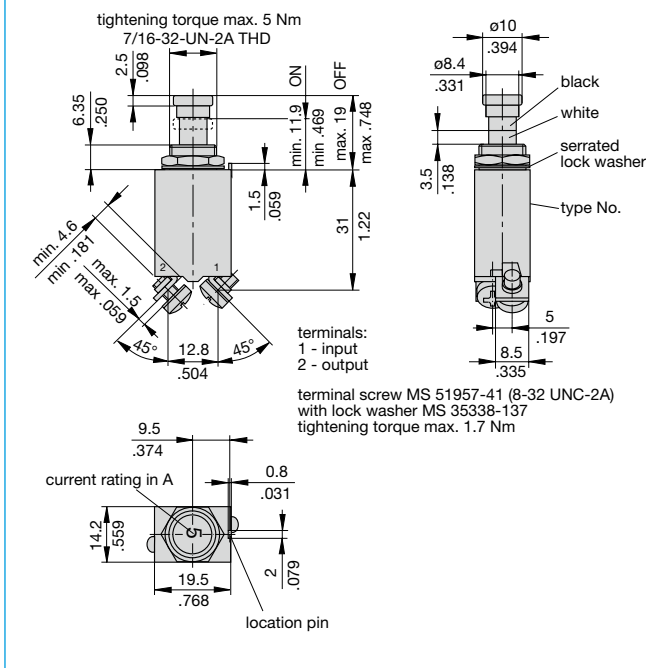

Dimensions 4120-G1..

4120-G111-K1M1-A1S0ZN (EN2495-...M) (VG95345 T06)

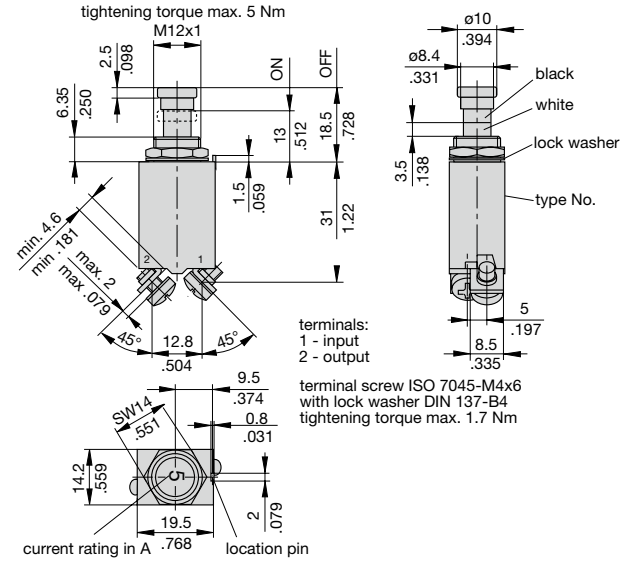

4120-G11-J2M1-K5S0ZN (EN2495-...U, EN3773-004 D...)

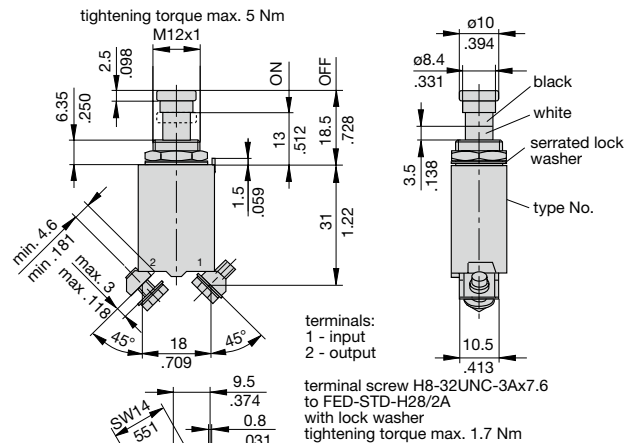

4120-G112-J2M1-K5S1ZG - 4120-G112-J2M1-K5S5ZG (EN2995-004)

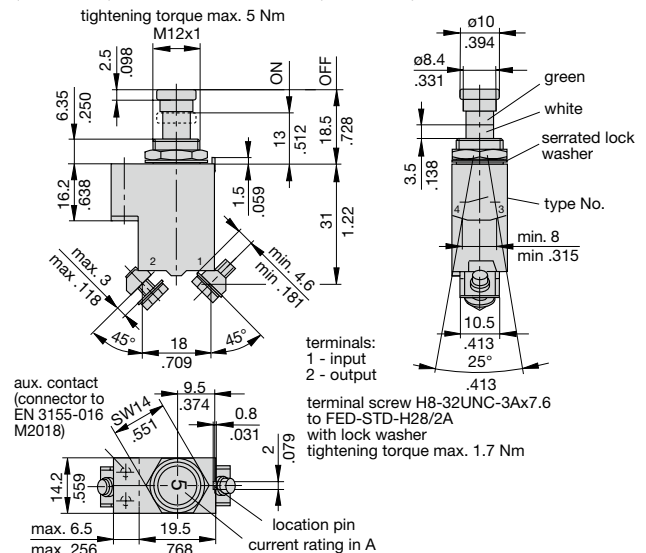

This is a metric design and millimeter dimensions take precedence (mm/inch)

Mounting holes

4120-G2...

mounting holes S0

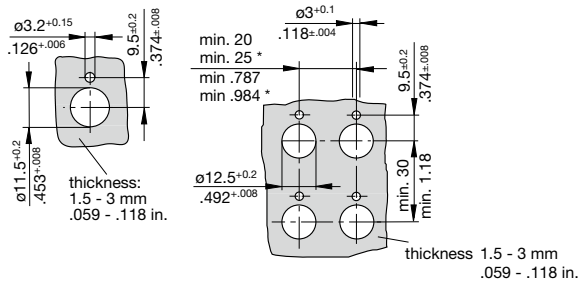

4120-G1...

mounting holes S1 or S5

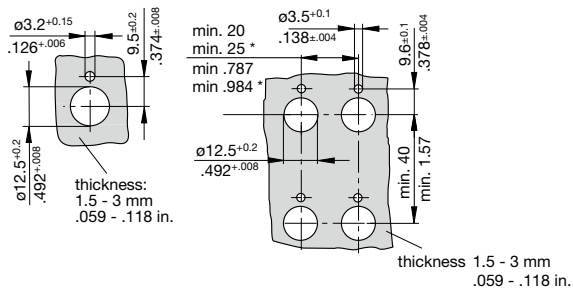

* min. 25 mm / .984 in. when fitted with splash cover

Internal connection diagram

with auxiliary contact VG 95345 T06

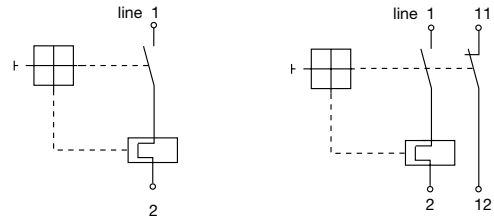

with auxiliary contact EN 2995-004

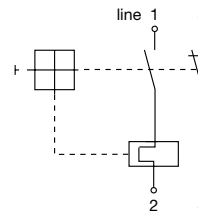

with polarized auxiliary contact EN 2995-005

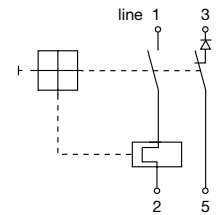

Other terminal designs

Terminal design -J2

Terminal distances to:
MS 14 105 (a, b)
MS 14 153 (a, b)
MS 22 073 (a)
MS 22 074 (a)
MS 25 244 (a)
MS 25 373 (a, b)

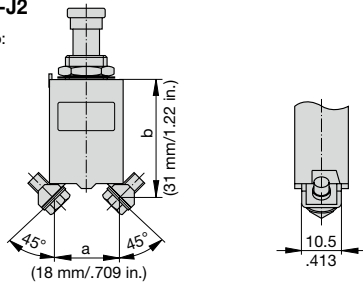

Terminal design -J3

Terminal distances to:
MS 26 574 (a, b)

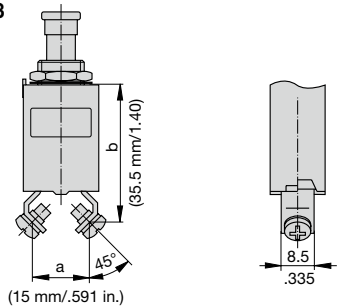

Terminal design -P1

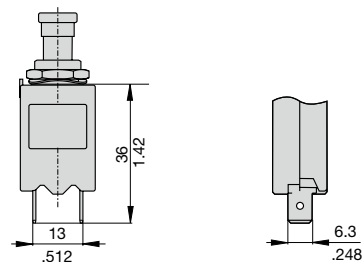

Typical time/current characteristics

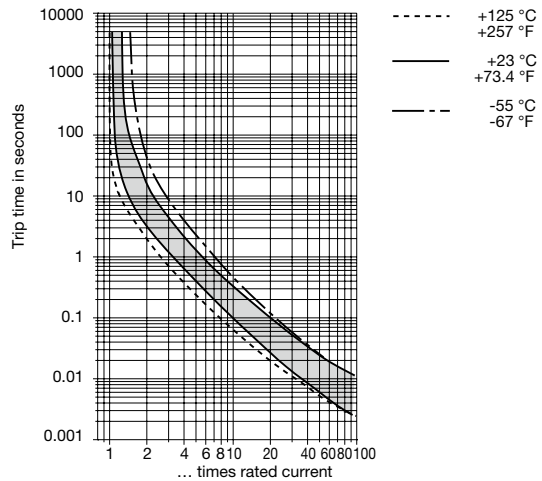

This is a metric design and millimeter dimensions take precedence ($\frac{\text{mm}}{\text{inch}}$)