

承認書

SPECIFICATION FOR APPROVAL

客戶(Customer): _____
客戶料號(Customer P/N): _____
機種編號(Files No.): _____
機種型號(Model No.): RB-2030008G-046LR-E
品名(Description): 喇叭
規格(Specification): 8Ω 1.0W

客戶承認欄 (Customer Authorization Signature)	供應商 (Supplier Audit)		
	Approver	Checker	Author
			謝淑芬
	日期: 2019 年 03 月 05 日		

Revision History

Version	Date	Description	Author
A0	2019-03-05	初始版本	謝淑芬

DONGGUAN FUXIN ELECTRONIC CO., L.T.D.

S P E C I F I C A T I O N

Above Measuring condition under temperature : 25~35℃ R.H. 25 ~75%. According to standard GB/T9396-1996

DONGGUAN FUXIN ELECTRONIC CO., L.T.D.

S P E C I F I C A T I O N

	Model	RB-2030008G-046LR-E		
1	Type	Dynamic Speaker		
2	Dimension	Outline Dimension Shall Be As Shown In Fig(1).		
3	Weight	Approx 3.0 Grams.		
4	Magnet	Material	Nd-Fe-B	
5	Impedance	8 ± 15% Ohm at 1000Hz. 1V		
6	Power Rating	Normal	1.0W	Maximum 1.5W
7	FO	670±20% Hz		
8	S.P.L.	96±3dB/1.0Watt 0.1Meter. Average At1000,1200,1500,2000 Hz.		
		Measurement Method Shown In Fig(2).		
9	Frequency Range	F0~20,000Hz.Average SPL-10dB. Frequency Response Fig (3).		
10	Distortion	10% Maximum At 1000Hz. 1.0W.		
11	Abnormal Sound Test	Must be Normal Tested by 2.83 Volts. Sine wave for50~5kHz		
12	Polarity	Diaphragm Shall Move Forward When Apply a Positive DC.		
		Red “+” or“ Marked” Terminal		
13	Operating Temperature	-20°C to +55 °C		
14	Storage Temperature	-25 °C to +65 °C		
15	Reliable Test			
After any following test leave speakers at room temperature for 1 hour, SPL shall not deviate by ±3 db from initial value				
15-1	Load Test	white noise for 96 hours at 1.0W input power.		
15-2	High Temperature Test	+65±2 °C 96hours		
15-3	Low Temperature Test	-25±2 °C 96hours		
15-4	Humidity Test	+40±2 °C relative humidity 90~95%R.H 96hours		
15-5	Vibration Test	Frequency 30 ±15 Hz, Amplitude 1.5 mm for 2 Hours per axis(x. y. z axis)		
15-6	Temperature Cycle test	- 25~ +65 °C 5 Cycles Temperature test.		
DATE		SPEC.NO		Version
2019-03-05		SCM		A0
				Page
				2/5
Model : RB-2030008G-046LR-E				

DONGGUAN FUXIN ELECTRONIC CO., L.T.D.

SPECIFICATION

16: Drawing(Fig1) Unit: mm Tolerance:±0.3mm

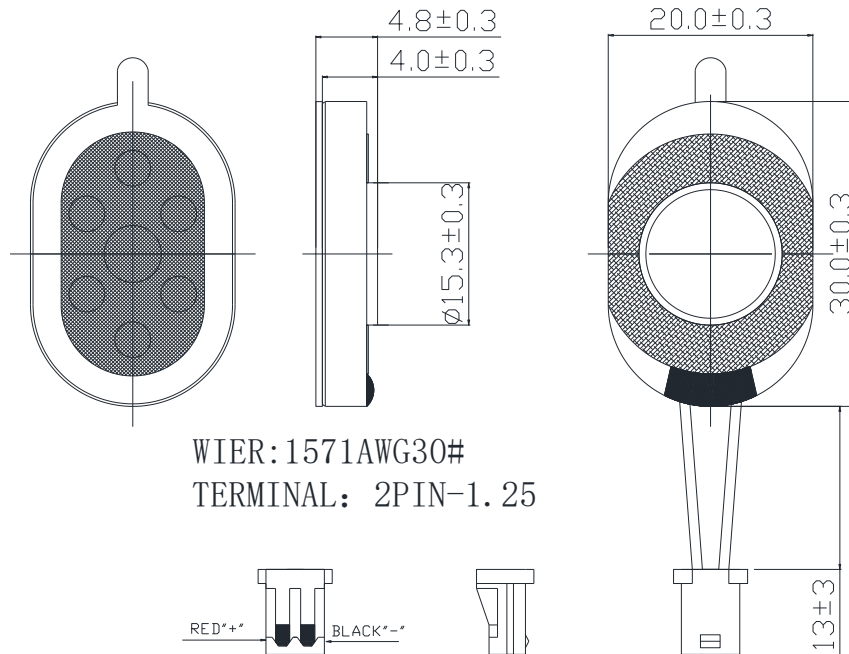

17. Speaker Construction

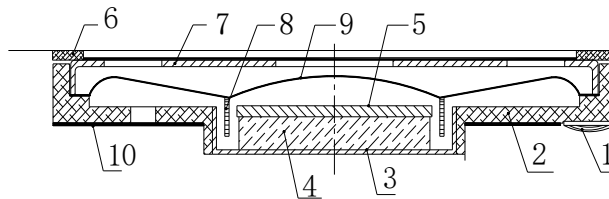

NO	PART NAME	MATERIAL	Q'TY
1	TERMINAL	FR-4	1
2	FRAME	PBT	1
3	YOKE	SPCC	1
4	MAGNET	Nd-Fe-B	1
5	WASHER	SPCC	1
6	EVA	EVA	1
7	COVER	SPCC	1
8	VOICE COIL	COPPER	1
9	DIAPHRAGM	PEN	1
10	CLOTH	CLOTH	1

DATE	SPEC.NO	Version	Page
2019-03-05	SCM	A0	3/5

18.Measurement Method Fig(2).

SPECIFICATION

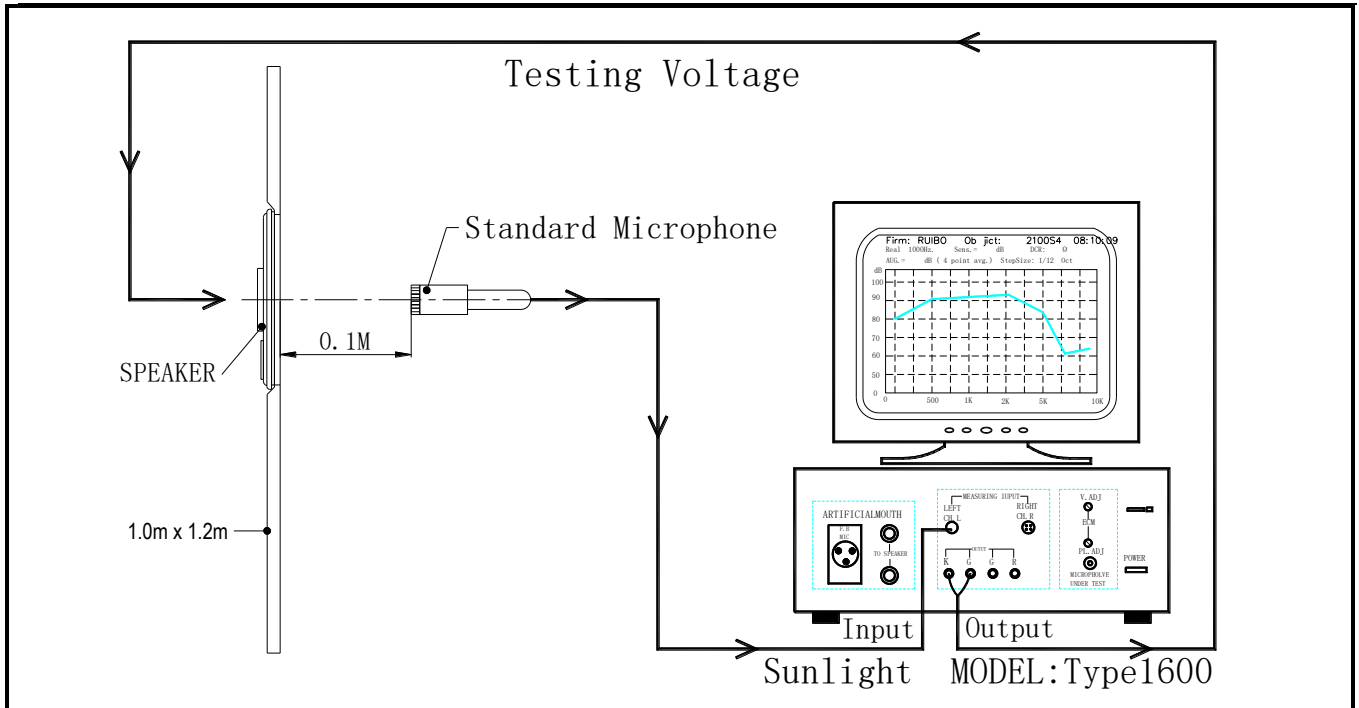

19. Test baffle Diagram

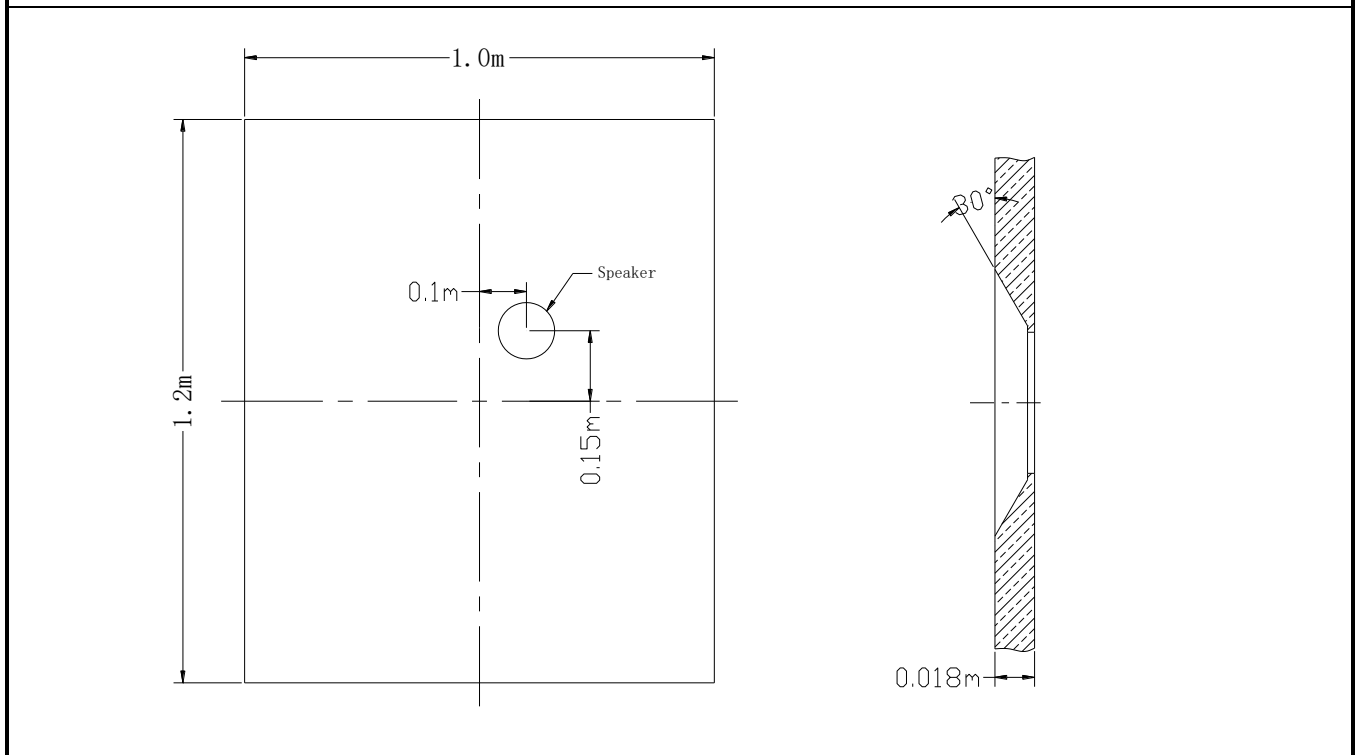

DATE	SPEC.NO	Version	Page
2019-03-05	SCM	A0	4/5

20. Frequency Resonance Fig (3).