

PART NUMBER CODE

426C7-1037F

SERIES PART NO

CUSTOM PART NO

FINISH SEE FINISH TABLE

[F] FINISH TABLE	
DASH NO	DESCRIPTION
A	NONE
C	CHEM FILM PER MIL-DTL-5541, CLASS 1A, TYPE I (CLEAR)
G	CHEM FILM PER MIL-DTL-5541, CLASS 1A, TYPE I (GOLD)
B	BLACK ANODIZE PER MIL-A-8625, TYPE II, CLASS 2
H	HARD BLACK ANODIZE PER MIL-A-8625, TYPE III, CLASS 2
N	NICKEL PLATE PER QQ-N-290, CLASS 1, GRADE G, BRIGHT
E	ELECTROLESS NICKEL PER MIL-C-26074, CLASS 4, GRADE B, BRIGHT
T	TRIVALENT CHEM FILM PER MIL-DTL-5541, CLASS 1A, TYPE II (CLEAR), RoHS COMPLIANT

REVISION HISTORY			
REV.	DESCRIPTION	DATE	DRAWN
00	INITIAL RELEASE	18 FEB 2014	RSB

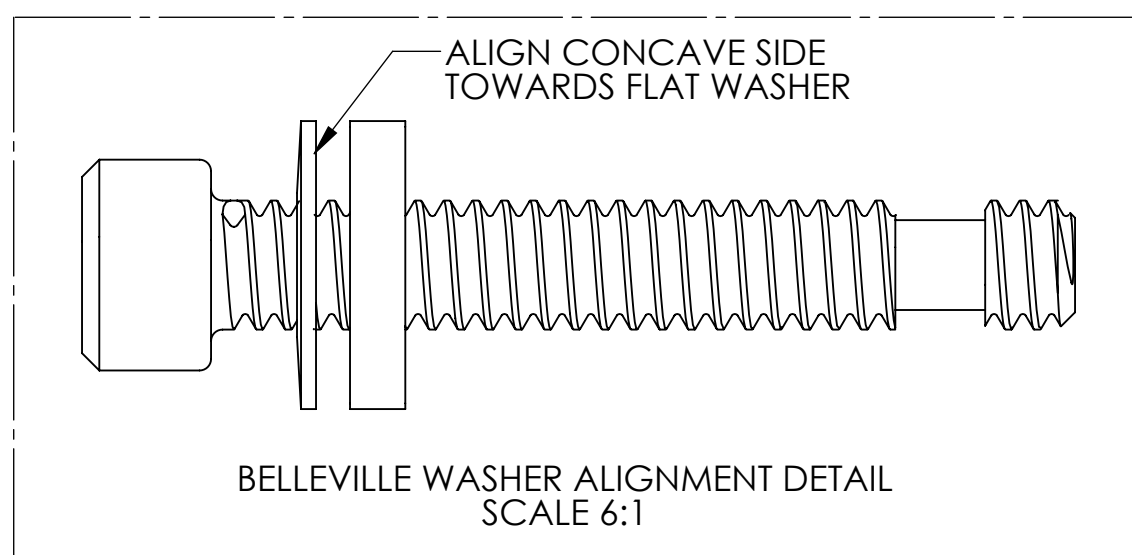
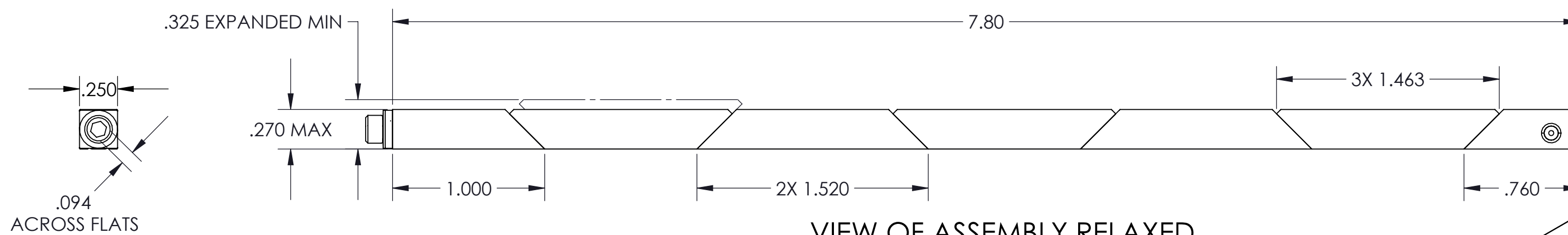
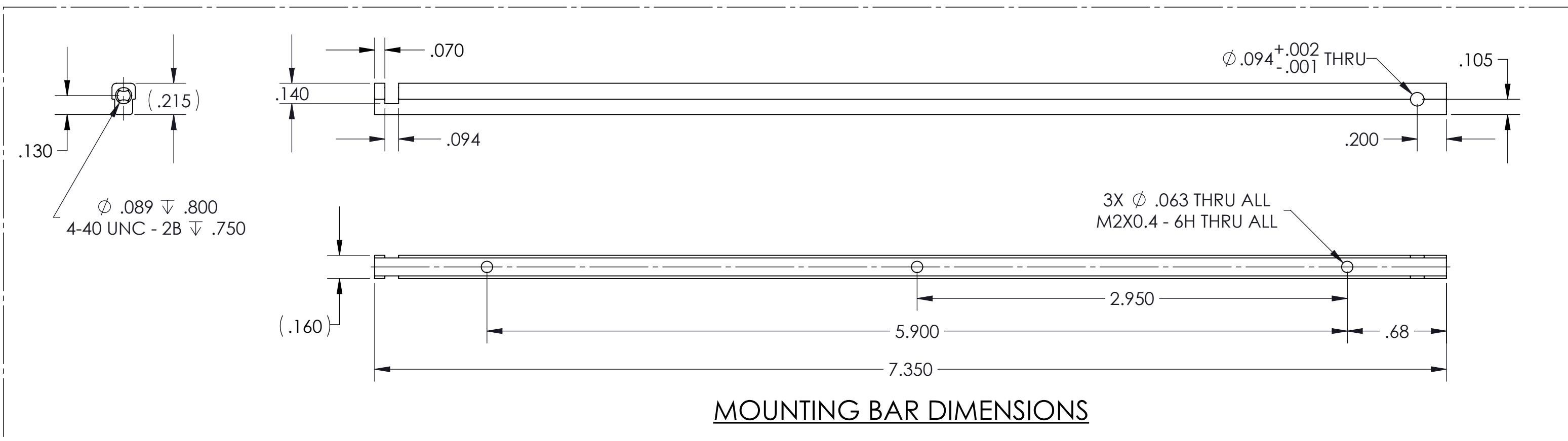

WASHERS MUST BE ASSEMBLED IN SEQUENCE SHOWN. SCREW INTO BAR SO THAT WEDGES REMAIN FLAT IN RELAXED POSITION.

PIN MUST NOT EXTEND PAST WEDGE SIDE WALLS

6	1220018-00	ROLL PIN .093D x .250L	1
5	4260006-00	FLAT WASHER	1
4	1040089-00	BELLEVILLE WASHER .25 OD x .013 THK	1
3	1020256KP-00	4-40 DRIVE SCREW, CAPTIVE, PATCH	1
2	4260080-780-00	WEDGE LENGTHS	1
1	4260079-735US-CK-00	MOUNTING BAR	1
ITEM	PART NO	DESCRIPTION	QTY

NOTES

- SEE PART NUMBER CODE FOR FINISH OPTION.
- IDENTIFY WITH WAKEFIELD-VETTE, PART NUMBER, AND DATE CODE PER MIL-STD-130.
- SHIP AS COMPLETE ASSEMBLY IN RELAXED STATE.

PROPRIETARY AND CONFIDENTIAL
THE INFORMATION CONTAINED IN THIS DRAWING IS THE SOLE PROPERTY OF WAKEFIELD-VETTE. ANY REPRODUCTION IN PART OR AS A WHOLE WITHOUT THE WRITTEN PERMISSION OF WAKEFIELD-VETTE IS PROHIBITED.

UNLESS OTHERWISE SPECIFIED:
DIMENSIONS ARE IN INCHES
TOLERANCES:
MACHINED SURFACES $\pm .005$
ANGULAR $\pm 1^\circ$
TWO PLACE DECIMAL $\pm .02$
THREE PLACE DECIMAL $\pm .005$
INTERPRET GEOMETRIC TOLERANCING PER: ASME Y-14.5M
DO NOT SCALE DRAWING

NAME: RSB
DATE: 18 FEB 2014
DRAWN: RSB
CHECKED:
APPR.:
THIRD ANGLE PROJECTION
CAGE CODE: 3E7UB

wakefield-vette
TITLE: WEDGELOCK, .260 x .250, 7.80" LENGTH
SIZE: C
DWG. NO.: 426C7-1037F
REV: 00
SCALE: 3:2
SHEET 1 OF 1