

NOTES (UNLESS OTHERWISE SPECIFIED):

1. ALL DIMENSIONS SHOWN IN () ARE REFERENCE ONLY.
2. THIS DRAWING ESTABLISHES GENERAL AND INSPECTION DIMENSIONS ONLY. ELECTRONIC FILE 430211B_REV_A IS TO BE USED AS THE GOVERNING DOCUMENT.
3. PART TO COME WITH TWO SET SCREWS, #6-32.
4. MATERIAL
 KNOB: MOLDED ABS, COLOR BLACK
 INLAY: ALUMINUM
 THREADED INSERT: BRASS

REVISIONS TABLE

REV	DESCRIPTION	DATE	ECN	INITIALS
A	INITIAL RELEASE	01/11/2023	----	SS

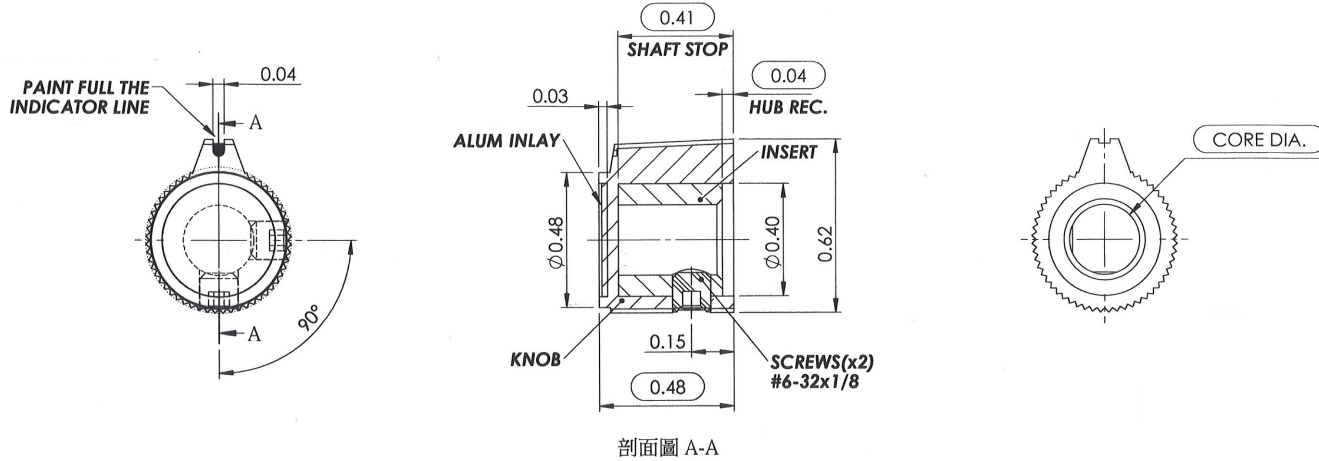

P/N	COLOR	CORE DIA.	INDICATOR COLOR
430211B14	BLACK	0.250 ^{+0.003} ₋₀	WHITE
430211B18		0.125 ^{+0.003} ₋₀	

UNLESS OTHERWISE SPECIFIED: DIMENSIONS ARE IN MILLIMETERS TOLERANCES : .X: ±0.25 ANGULAR: ±1° .XX: ±0.15		NAME	DATE
3rd ANGLE PROJECTION <input checked="" type="checkbox"/> : CRITICAL DIMENSIONS		DRAWN BY: SSasaki	01/11/2023
COMMENTS:		CHECKED: CMurua	01/11/2023
FORM NO. EF-310, Rev_B 10/11/17		EngAPRVL: SLamadrid	01/11/2023
		MATERIAL:	
		FINISH:	

<p>an IDEC company</p> <p>MANUFACTURERS OF MAN-MACHINE INTERFACE PRODUCTS. 970 PARK CENTER DR., VISTA, CA 92081 TEL: (760) 598-2518 FAX: (760) 598-2524</p>		<p>THIS DOCUMENT CONTAINS PROPRIETARY INFORMATION OF APEM, INC. AND IS TENTED SUBJECT TO THE CONDITIONS THAT THE INFORMATION (A) BE RETAINED CONFIDENCE, (B) NOT REPRODUCED OR COPIED IN WHOLE OR PART, (C) NOT BE LEASED TO THIRD PARTY AND, (D) NOT BE USED OR INCORPORATED IN ANY PRODUCT EXCEPT UNDER EXPRESSED WRITTEN AGREEMENT WITH APEM, INC.</p>	
TITLE: KNOB, STRAIGHT KNURL, LINE INDICATOR			
SIZE: A	PRJCT/ACCT NO. --- FILE NO. ---	DWG NO. 430211B	REV. A
SCALE: NONE	DO NOT SCALE DRAWING	SHEET 1 OF 1	