

DATA SHEET

GAS DISCHARGE TUBES
TELEPHONE INTERFACE

4532 series

RoHS compliant & free



Product specification— July 12, 2023 V.1



Gas Discharge Tube (GDT) Data Sheet

Features

- High insulation resistance
- Low capacitance ($\leq 0.5\text{pF}$)
- 2KA 8/20 μs maximum surge current capacity in accordance with IEC 61000-4-5& IEC 61643-311
- 4KV 10/700 μs maximum surge rating in accordance with ITU-TK.21
- Surface mounted gas arrester
- Micro-Gap Design
- Size 4532(1812)
- Storage and operating temperature: $-40^{\circ}\text{C} \sim +90^{\circ}\text{C}$
- Meets MSL level 1, per J-STD-020
- Safety certification: UL & TUV



Applications

- Repeaters, Modems
- Telephone Interface, Line cards
- Data communication equipment
- Line test equipment

Part Number Code and Marking

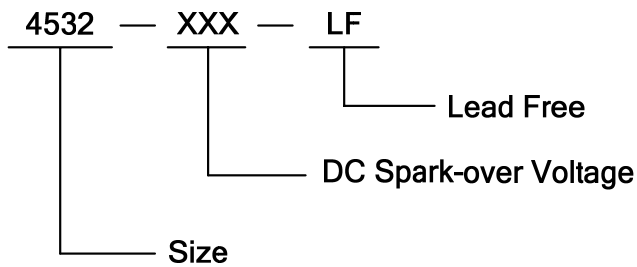

090: Device Marking Code

Dimensions

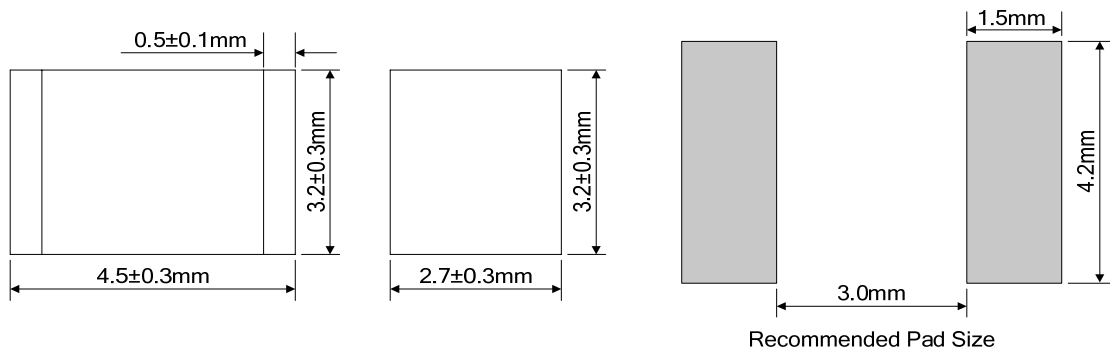

Electrical Characteristics

Part Number	DC Spark-over Voltage	Maximum Impulse Spark-over Voltage	Nominal Impulse Discharge Current	Impulse Withstanding Voltage Capacity	Minimum Insulation Resistance		Maximum Capacitance	Device Marking Code
	100V/s	1000V/ μ s	8/20 μ s 10times	10/700 μ s 10times	Test Voltage	(G Ω)	(1MHz 1V)	
	(V)	(V)	(KA)	(KV)	DC(V)		(pF)	
4532-075-LF	75 \pm 30%	600	2	4	50	1	0.5	075
4532-091-LF	90 \pm 30%	700	2	4	50	1	0.5	090
4532-121-LF	120 \pm 30%	700	2	4	50	1	0.5	120
4532-151-LF	150 \pm 30%	700	2	4	50	1	0.5	150
4532-201-LF	200 \pm 30%	750	2	4	100	1	0.5	200
4532-231-LF	230 \pm 30%	750	2	4	100	1	0.5	230
4532-301-LF	300 \pm 30%	900	2	4	100	1	0.5	300
4532-351-LF	350 \pm 30%	900	2	4	100	1	0.5	350
4532-401-LF	400 \pm 30%	1000	2	4	100	1	0.5	400
4532-421-LF	420 \pm 30%	1000	2	4	100	1	0.5	420
4532-471-LF	470 \pm 30%	1000	2	4	100	1	0.5	470
4532-501-LF	500 \pm 30%	1100	2	4	100	1	0.5	500
4532-601-LF	600 \pm 30%	1200	1	4	100	1	0.5	600
4532-801-LF	800 \pm 30%	1600	1	4	100	1	0.5	800
4532-1000-LF	1000 \pm 20%	2400	1	4	100	1	0.5	102
4532-1200-LF	1200 \pm 20%	2600	1	4	100	1	0.5	122
4532-1500-LF	1500 \pm 20%	2800	1	4	100	1	0.5	152

Electrical Ratings

Items	Test Condition/Description	Requirement
DC Spark-over Voltage	The voltage is measured with voltage ramp dv/dt=100V/s.	To meet the specified value
Maximum Impulse Spark-over Voltage	The maximum impulse spark-over voltage is measured with voltage ramp dv/dt=1000V/ μ s.	
Insulation Resistance	The resistance of gas tube shall be measured between two electrodes.	
Capacitance	The capacitance of gas tube shall be measured between two electrodes. Test frequency: 1MHz	
Impulse Discharge Current	Maximum 8/20 μ s surge current that can be applied between two electrodes, 5 positive and 5 negative surges, with 3 minutes interval time.	
Impulse Withstanding Voltage	The maximum 10/700 μ s surge that can be applied to the Gas Tube, 5 positive and 5 negative surges, with 1 minute interval time.	

Recommended Soldering Conditions

Reflow Soldering

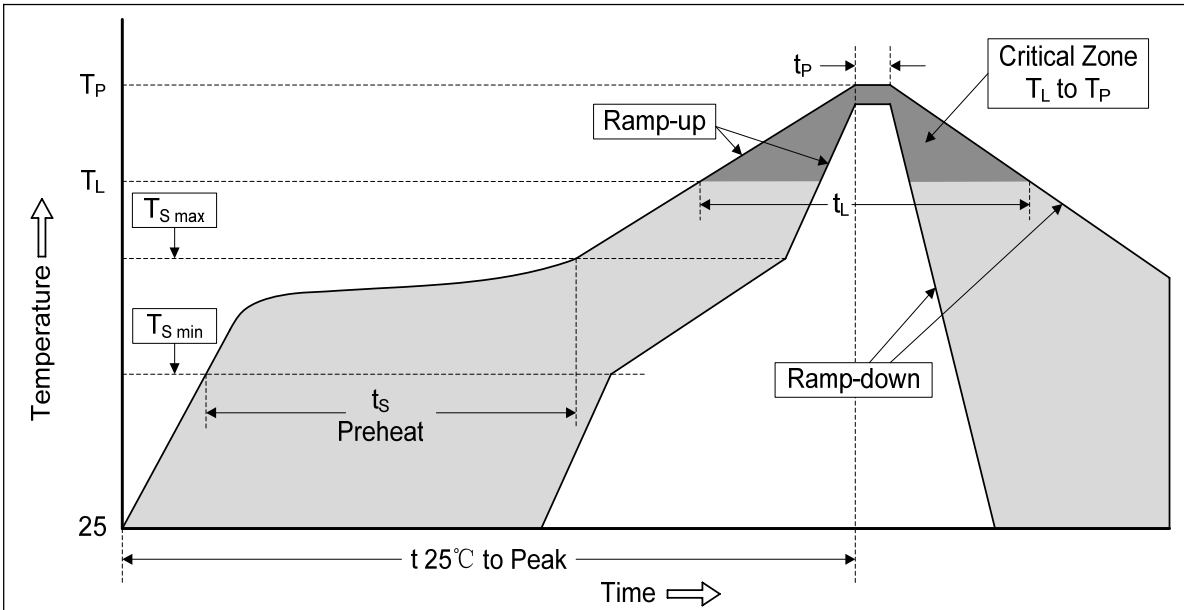

Profile Feature	Pb-Free Assembly
Average ramp-up rate (T _L to T _P)	3°C/second max.
Preheat -Temperature Min (T _{S min}) -Temperature Max (T _{S max}) -Time (min to max) (t _s)	150°C 200°C 60-180 seconds
T _{S max} to T _L -Ramp-up Rate	3°C/second max.
Time maintained above: -Temperature (T _L) -Time (t _L)	217°C 60-150 seconds
Peak Temperature (T _P)	260°C
Time within 5°C of actual Peak Temperature (t _P)	20-40 seconds
Ramp-down Rate	6°C/second max.
Time 25°C to Peak Temperature	8 minutes max.

Packaging

Tape

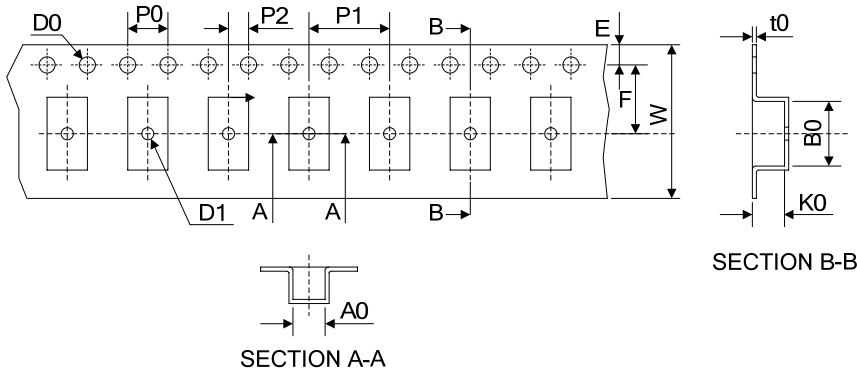

Items	Dimension (mm)	
	Spec.	Tolerance
W	12.00	±0.20
P0	4.00	±0.10
P1	8.00	±0.20
P2	2.00	±0.10
D0	1.55	±0.10
D1	1.00	±0.10
E	1.75	±0.10
F	5.50	±0.10
A0	3.80	±0.10
K0	3.20	±0.10
B0	4.90	±0.10
t0	0.40	±0.10
D	330.00	±2.00
d	13.00	±0.50
L	16.00	±2.00
t	2.00	±0.20
Quantity: 2500pcs		

Reel

