

# User Guide

## External Temperature Sensor

*Version 1.1*

---

## REVISION HISTORY

Version	Date	Notes	Contributors	Approver
1.0	07 Jan 2019	Initial Release	Robert Gosewehr	Chris Hofmeister
1.1	28 Aug 2019	Reflect new part numbers and modified probe specification	Chris Boorman	Jonathan Kaye

## CONTENTS

1	Introduction.....	4
2	Part Numbers .....	4
3	Installation .....	5
3.1	Illustrations .....	6
3.1.1	Stainless Steel Temperature Probe with RJ45 Cable Assembly .....	6
3.1.2	RJ45 Cable Gland .....	7
4	Connection Status .....	8
5	Data Visualization.....	9
5.1	Sentrius Sensor Mobile App.....	9
6	Battery Consumption .....	10
7	Sanitation and Cleanliness .....	10

## 1 INTRODUCTION

This User Guide explains how to properly install the Laird External Temperature Probe kit for the Sentrius Sensor series and view sampled data using the Sentrius Sensor Mobile App.

This variant of the Sentrius RS1xx series of LoRa / BLE Sensors enables use of an external cabled temperature probe, in place of the integrated temperature sensor. The kit includes an IP67 rated cabled temperature probe that is 200mm in length and 6.35mm in diameter at the stainless-steel probe end. The external temperature probe utilizes a One Wire digital interface and supports a general temperature range of -55° to +125°C (+/-0.9°C). The cabled probe connects into the main body of the Sentrius Sensor via a CAT5 IP67 rated RJ45 connector.

**Note:** This guide only contains a brief walkthrough. Refer to the RS1xx Guide for further details on sensor functionality and the mobile app capabilities. To access the RS1xx Guide, navigate to the [RS1xx product page](#), click Documentation, and select the *Sentrius RS1xx User Guide*.

## 2 PART NUMBERS



Figure 1: Sentrius sensor with external temperature probe

Reference	Description
Left	IP67-rated, 1520 mm overall length, 213 mm probe length, 6.0 mm diameter stainless steel temperature probe CAT5 RJ45 connector
Right	Sentrius™ RS1xx LoRaWAN Ext Port Temp Sensor

The external temperature probe is ordered separately from the Sensor body, in single or bulk. See the Laird [RS1xx product page](#) for ordering information.

### 3 INSTALLATION

To install the external temperature sensor, refer to [Figure 2](#) and follow these steps:

1. Unscrew the Ethernet cap (1) from the Sentries Sensor.
2. Connect the RJ45 connector from the cable assembly into the external port of the Sentries Sensor.
3. Screw on (by hand) the top portion of the cable gland – the screw nut (3) – until tight.
4. Visually check to ensure the lower portion of the cable gland – the pressing screw (2) – is also tight.



**Figure 2: Installing the external temperature sensor**

---

**Note:** Ensure that references (2) and (3) in [Figure 2](#) are tight when installing the external temperature probe into the Sentries Sensor. If these areas are not sufficiently tightened, this could lead to a potential leak and cause damage to the sensor's external port connector or to the temperature probe cable assembly.

---

### 3.1 Illustrations

#### 3.1.1 Stainless Steel Temperature Probe with RJ45 Cable Assembly

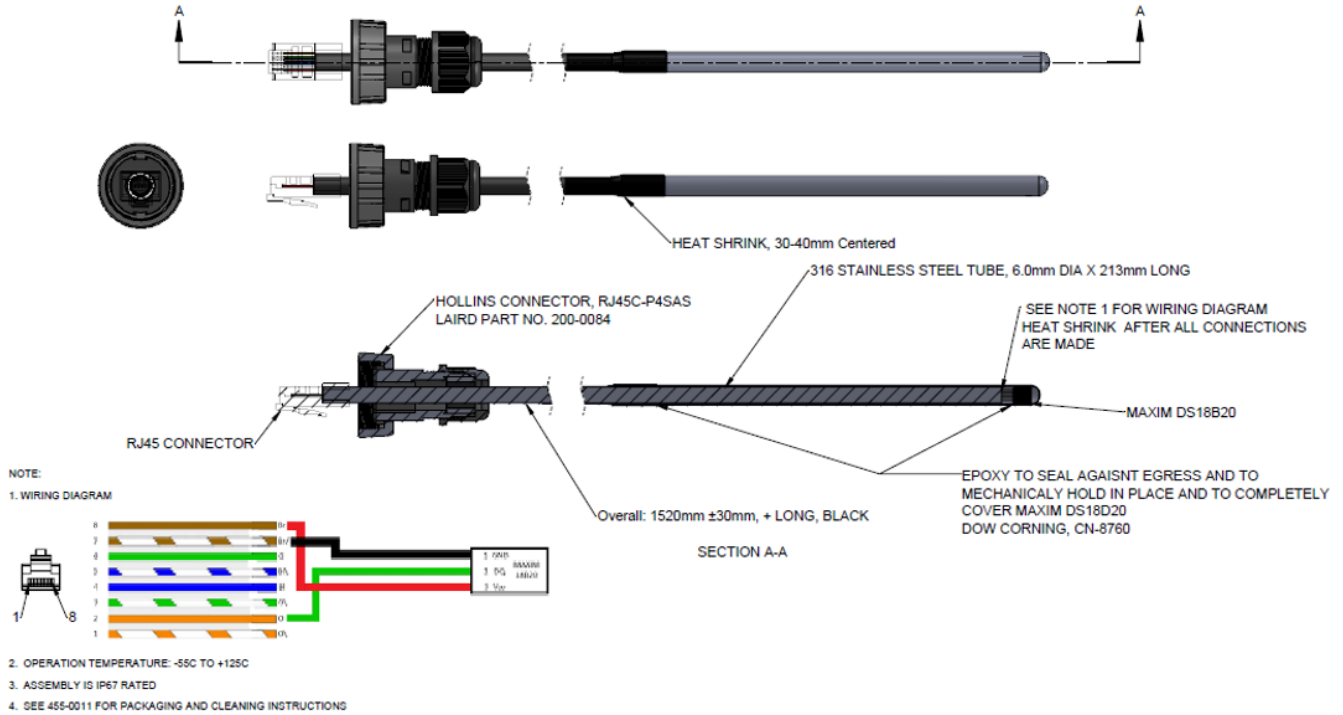
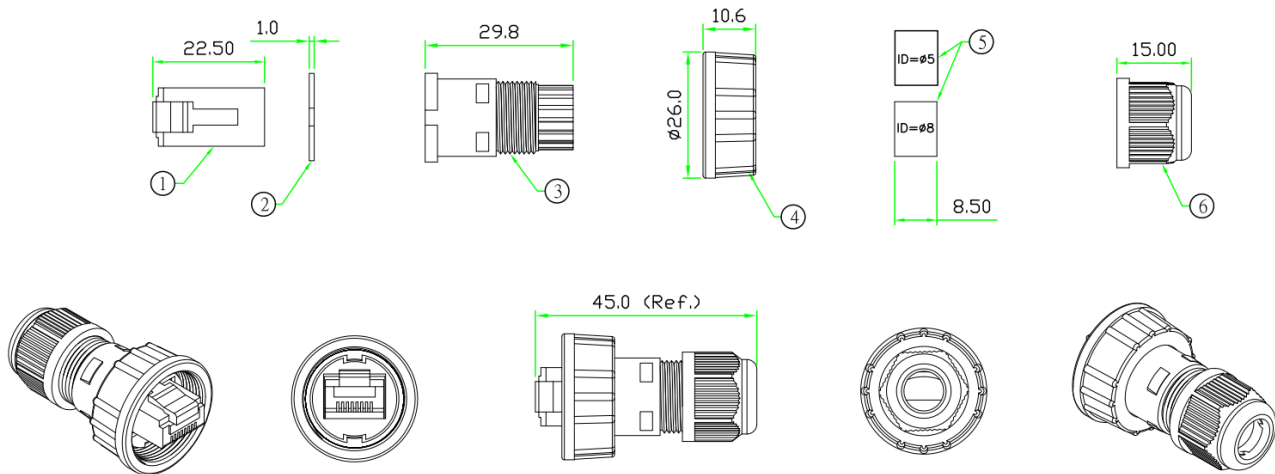

Figure 3: Stainless steel temperature probe with RJ45 cable assembly

### 3.1.2 RJ45 Cable Gland

(DIM in millimeters)



6	SCREW	PRESSING SCREW, NYLON.	BLACK	1
5	SEAL	SANTOPRENE. for cable OD: 3~5mm & 5~8mm.	BLACK	2
4	SCREW NUT	SCREW NUT, NYLON+GF.	BLACK	1
3	SLEEVE	CABLE SLEEVE, NYLON.	BLACK	1
2	GASKET	RUBBER	BLACK	1
1	RJ-45 PLUG	RJ-45 8P8C SHIELDED PLUG.		1

Figure 4: RJ45 cable gland

## 4 CONNECTION STATUS

When the external probe is connected properly to the sensor, the sensor will operate “normally” once powered up. Normal operation of the sensor is indicated by the left LED will flashing either “orange” or “green” color to indicate the connection status to a network.

A connection problem at power up is indicated by both LEDs on the front panel both being constantly on. This is a visual indicator to the user that there is a communication issue between the sensor and the probe. If the sensor cannot detect the external probe it will not function properly.

To remedy this, follow these steps:

1. Retry the steps from the [Installation](#) section. Make sure the sensor has the latest firmware installed to ensure the sensor has all the latest capabilities. The firmware can be updated using the mobile app. Reference the RS1xx guide for more details [RS1xx product page](#) on this process.
2. The time it takes for the sensor to detect a probe depends on the sensor’s settings, in particular, the read period and aggregate count. This means that the time to auto detect a probe can fluctuate between 30 seconds or likely much longer.

To speed up the auto detect process of the sensor, press and hold the Bluetooth button  on the top of the sensor for five seconds after reconnecting the external probe. This will restart the sensor, and on startup the Sentries sensor will check for the sensor.

The sensor monitors the status of the external probe on each temperature measurement. If the external probe is damaged or disconnected it will be shown by the LoRa status LED. The LoRa status LED flashes at the heartbeat interval to indicate a network connection. If the external probe becomes disconnected, the LoRa status LED will quickly flash orange three times immediately after the heartbeat indication. When the external probe is reconnected, the heartbeat LED will return to normal operation.

3. If you continue to experience an issue, contact [Laird Support](#). There could be damage to the Sentries sensor or probe.



Figure 5: Front panel LEDs are lit



## 5 DATA VISUALIZATION



### 5.1 Sentrius Sensor Mobile App

The Sentrius mobile application allows a user to configure a device, troubleshoot a device, see real-time sensor data, and update firmware. Search the appropriate app store ([Google Play Store](#), [Apple Store](#), or the [Microsoft Store](#)) for the Sentrius Sensor App and install it on your device.

**Note:** This guide only contains a brief walkthrough. Refer to the RS1xx Guide for further details on sensor functionality and the mobile app capabilities. To access the RS1xx Guide, navigate to the [RS1xx product page](#), click Documentation, and select the **Sentrius RS1xx User Guide**.

The Sentrius sensor mobile app displays real-time sensor data from the external temperature probe and sensor once a good cable connection is established.

To view real-time sensor data, follow these steps:

1. Press and hold the BLE button  on the front panel of the sensor to start BLE advertising on the device.
2. Select the corresponding DEV EUI on the connection screen of the mobile app. The DEV EUI of the sensor can be found on the back label of the sensor.
3. Once connected to the mobile app, click the Temperature Reading icon  under the Temperature/Humidity section to see real-time sensor data from the temperature probe.

From this screen, the temperature probe can be validated by confirming the temperature measurements are accurate. Place your hand on the probe to fluctuate the temperature.

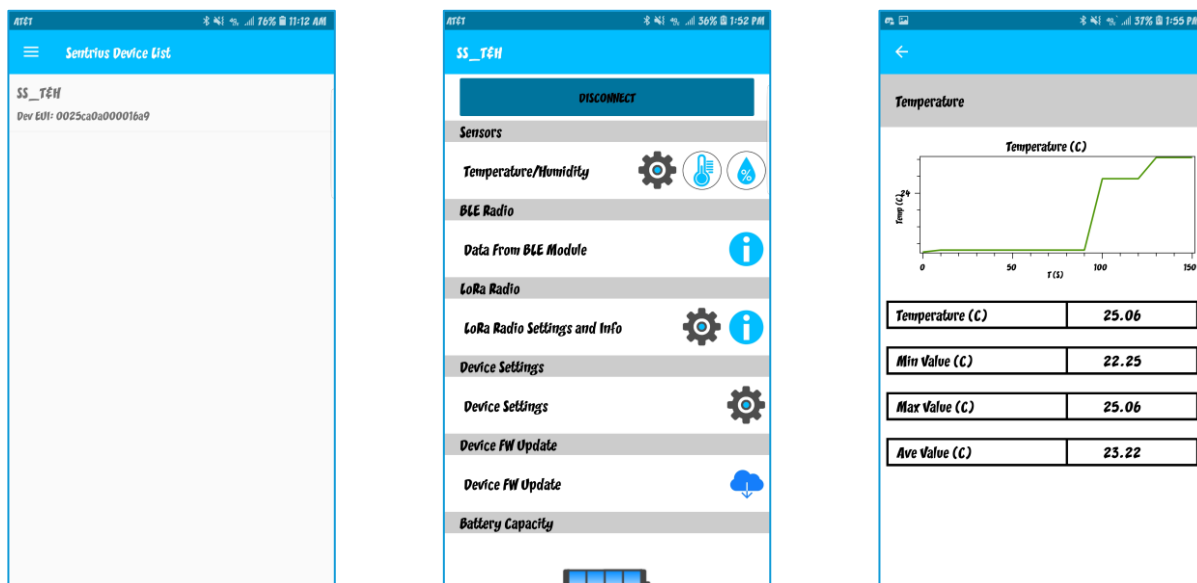



Figure 6: Sentrius sensor mobile app displays

Update the sensor settings on the main screen  to get a faster reading period if the temperature readings are taking too long to update on the graph. The fastest read period a sensor can have is thirty seconds.