



## VCNL4000



### Integrated Proximity / Ambient Light Sensor

Industry's First Optical Sensor Combining an IR Emitter, PIN Photodiode, and Ambient Light Detector with 16-bit Resolution and I<sup>2</sup>C Interface

#### FEATURES AND BENEFITS

- Low profile surface-mount package: 3.95 mm x 3.95 mm x 0.75 H mm
- Integrated module with infrared emitter, ambient light sensor, proximity sensor, and signal conditioning IC
- Greatly simplifies window optics and PCB layout
- Communication via I<sup>2</sup>C interface
- Low standby current consumption: 1.5  $\mu$ A

#### PROXIMITY FUNCTION

- 16-bit effective resolution
- Excellent crosstalk immunity
- Programmable LED drive current from 10 mA to 200 mA in 10 mA steps
- Programmable measurement rate from 1 Hz to 250 Hz
- Proximity distance up to 20 cm (8 in)

#### AMBIENT LIGHT FUNCTION

- Built-in ambient light PIN photodiode with close to human eye sensitivity characteristic
- 16-bit dynamic range for ambient light detection from 0.33 lx to 13 klx
- 100 Hz and 120 Hz flicker noise rejection

#### APPLICATIONS

- Proximity sensor for mobile devices: smart phones, digital cameras, tablet PCs
- Ambient light sensors for any display or keypad backlight to reduce power consumption and optimize visibility of the screen based on lighting conditions
- Industrial controls where action is driven based on proximity of an object or ambient light conditions
- Gaming, entertainment

Datasheet and application note available on our website at <http://www.vishay.com/doc283798>

## NO MECHANICAL BARRIER NEEDED

Designing a discrete IR emitter, proximity sensor, and ambient light sensor into a smart phone and avoiding optical crosstalk is next to impossible. Combining the proximity and ambient light sensor into a single package is one step in the right direction but it still leaves the difficulty of isolating the emitter from these detectors.

The VCNL4000 takes that next step by integrating a proximity and ambient light sensor with the infrared emitter. This stand-alone, single component greatly simplifies design by making the mechanical barriers unnecessary. The VCNL4000 is the industry's first optical sensor to offer proximity and ambient light sensing with 16-bit resolution and I<sup>2</sup>C interface. It has the industry's best range of up to 20 cm (8 in).

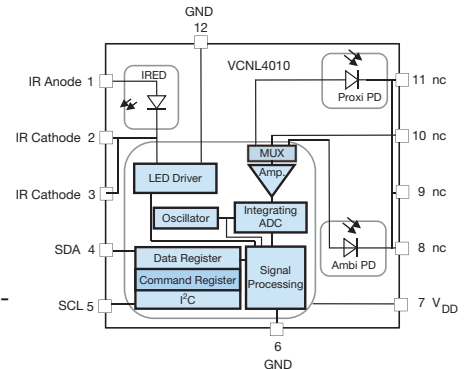

## MODULATION ELIMINATES DC LIGHT NOISE

The integrated **infrared emitter** has a peak wavelength of 890 nm. It emits light that reflects off an object within 20 cm of the sensor. The infrared light emitted is modulated at one of four user defined carrier frequencies: 390.625 kHz, 781.25 kHz, 1.5625 MHz, or 3.125 MHz.

The **PIN photodiode** receives the light that is reflected off the object and converts it to a current. It has a peak sensitivity of 890 nm, matching the peak wavelength of the emitter. It is insensitive to ambient light. It ignores the DC component of light and 'looks for' the pulsed light at one of the four frequencies used by the emitter. **Using a modulated signal for proximity provides distinct advantages over other sensors on the market.**

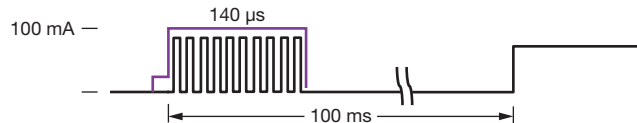

## 16-BIT RESOLUTION YIELDS CLEAR SIGNAL

Even with a dirty, scratched or poor IR transparent window, the 16-bit resolution compensates and delivers excellent range and response. The proximity sensor will work well in all lighting conditions and with any transparent cover.

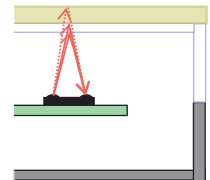

Application Schematic Examples

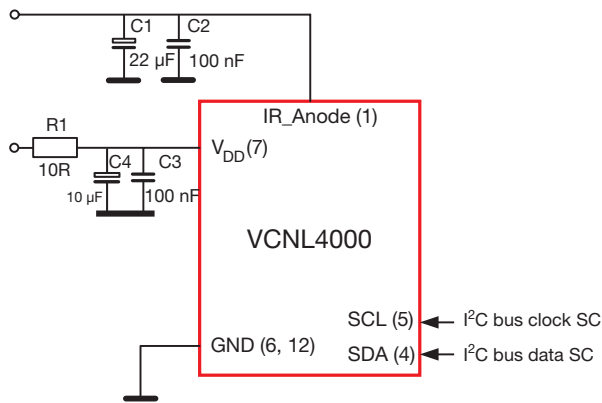

Ambient Light Sensor Performance

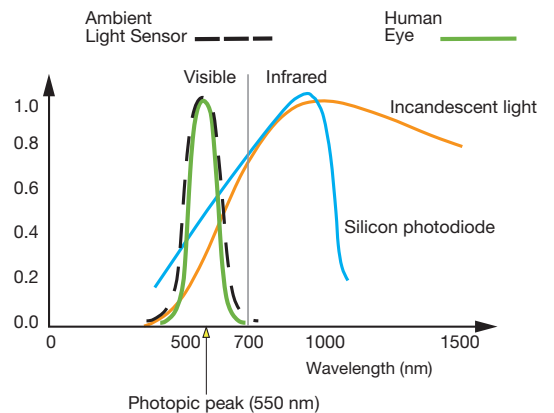

Build **Vishay** into your **Design**