

SMART BATTERY ISOLATOR

Prevents Loads On Auxiliary Battery From Draining The Starting Battery

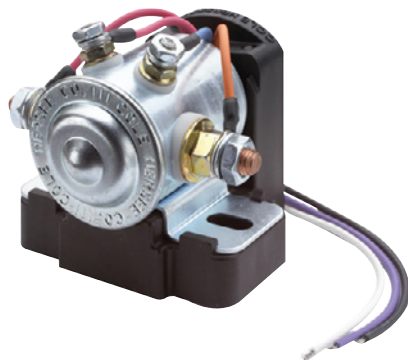

Description

More flexible than traditional Isolators and works with all alternator types. The Smart Battery Isolators are smaller, lighter, less heat generated. No diode efficiency losses and reduces charging system workload by not connecting auxiliary battery until primary battery is charged to 13.2V. Lower strain on expensive charging components extends their useful life. Allows bi-directional charging from alternator or from shore/campground power charger/converter when available.

Features and Benefits

- Simple installation - Connect to starting battery, auxiliary battery, and ground.
- LED status indicator.
- Optional Start Assist – Momentary switch allows the auxiliary battery to assist the starting battery.

Specifications Overview

Max Input Voltage:	16V
Continuous Current:	48525 – 85A 48530 – 200A
Ingress Protection:	IP65
Vibration:	10-500Hz
Operating Temperature Range:	-40 to +85 °C

Web Resources

Download technical resources at:
littelfuse.com/SmartBatteryIsolator

Ordering Information

PART NUMBER	AMPERAGE
48525	85A
48530	200A

Dimensions

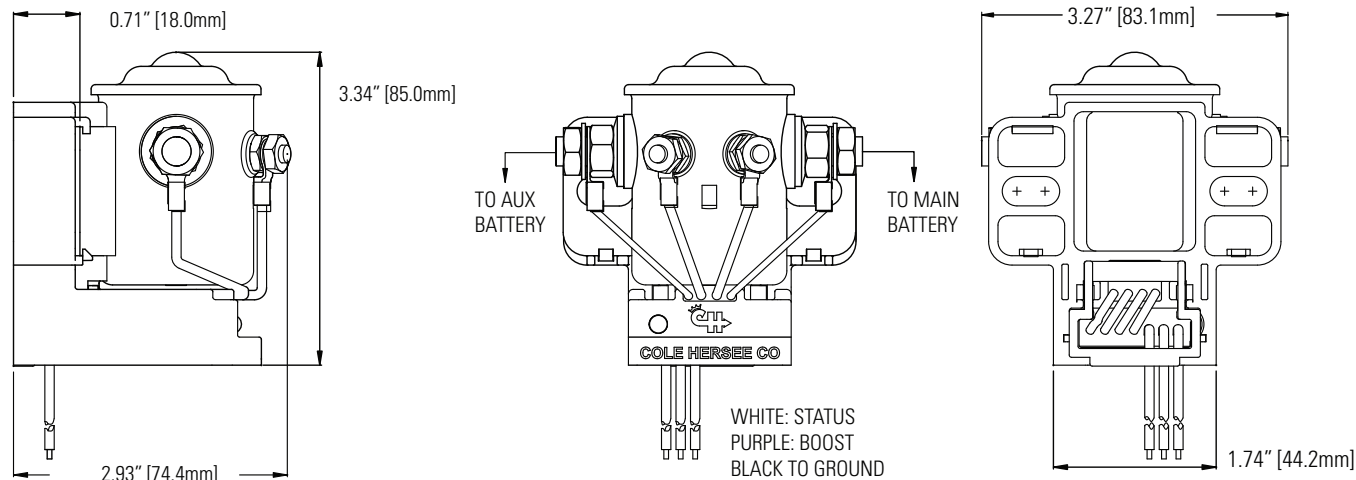

Datasheet Replaces Hotfeed Number D-617

SMART BATTERY ISOLATOR

Electrical Characteristics

CHARACTERISTIC	MIN	TYPICAL	MAX	NOTES
Normal Input Voltage	9V		16V	Voltage range unit is guaranteed to function within specification.
Continuous Current 48525 48530		85A 200 A		
Connect Voltage		13.2V		After 2 minutes at this level
Disconnect Voltage		12.7V		After 1 minute at this level
Quiescent Current		5mA	8mA	Relay off, start signal input open or grounded

Environmental Specifications

PER SAE J1455	PARAMETER	NOTES
Operating Temperature Range	-40 to +85 °C	Operating condition
Ingress Protection	IP65	Per IEC
Humidity	0 to 90% RH	
Vibration	10-500Hz	per SAE J1455
Shock		per SAE J1455
Thermal Shock		per SAE J1455
EMI/RF		per SAE J1455 & J1113

Terminal Torque Specifications

Battery Terminals	5/16-24	50 in-lbs (5.78 Nm)
--------------------------	---------	---------------------



Visit Littelfuse.com for the most up-to-date product information. Littelfuse products are designed for specific applications and should not be used for any purpose (including, without limitation, automotive applications) not expressly set forth in applicable Littelfuse product documentation. Warranties granted by Littelfuse shall be deemed void for products used for any purpose not expressly set forth in applicable Littelfuse product documentation. Littelfuse shall not be liable for any claims or damages arising out of products used in applications not expressly intended by Littelfuse as set forth in applicable Littelfuse product documentation.

Datasheet Replaces Hotfeed Number D-617

HOW A SMART BATTERY ISOLATOR WORKS

Normal Operation Sequence

1 When the vehicle has been running, the alternator charges both battery banks through the Smart Isolator.

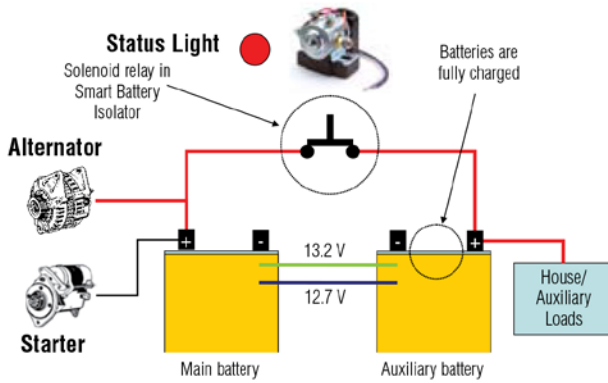

2 When the engine is turned off, the alternator no longer supplies a charge to the batteries, and the loads on the batteries begin to deplete them.

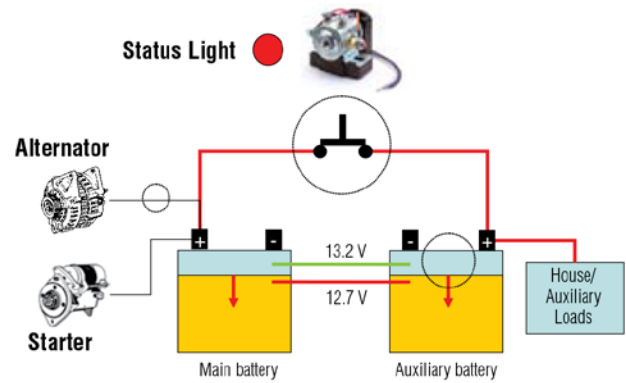

3 When batteries reach 12.7V, the Smart Battery Isolator senses it, opens the solenoid relay to separate the battery banks, and turns off the status light. This protects the starting battery while allowing the auxiliary battery to continue to power the auxiliary loads.

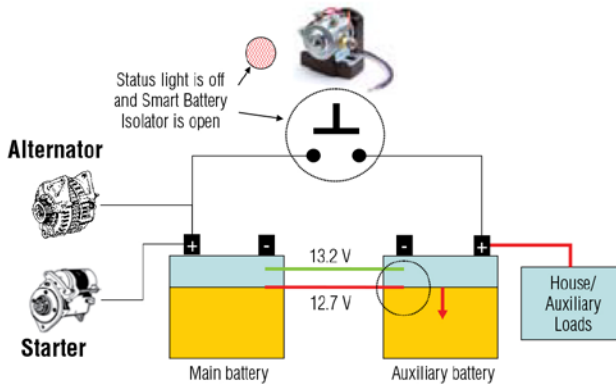

4 When the vehicle is restarted, the starting battery has enough power to crank the engine, but the auxiliary battery is significantly depleted. The Smart Battery Isolator is open and the battery banks are separated.

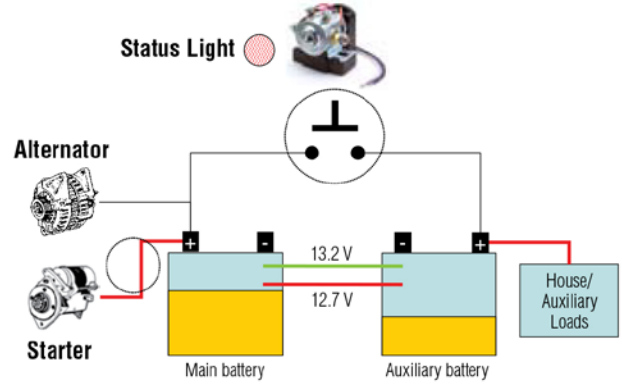

5 The engine is powering the alternator, and the starting battery has reached 13.2V. Only now does the Smart Battery Isolator reconnect, enabling the depleted auxiliary battery to be charged. By not reconnecting until the main battery is charged, the alternator is protected from excessive loads.

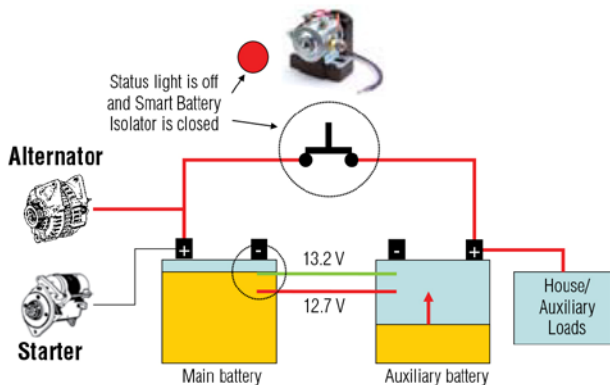

6 Now both batteries are charged again.

