

# 4DCAPE-43 Series

4DCAPE-43 (4.3" Non-Touch)  
4DCAPE-43T (4.3" Resistive Touch)

## Datasheet

Revision 1.5

Copyright © 2023 4D Systems

Content may change at any time. Please refer to the resource centre for latest documentation.

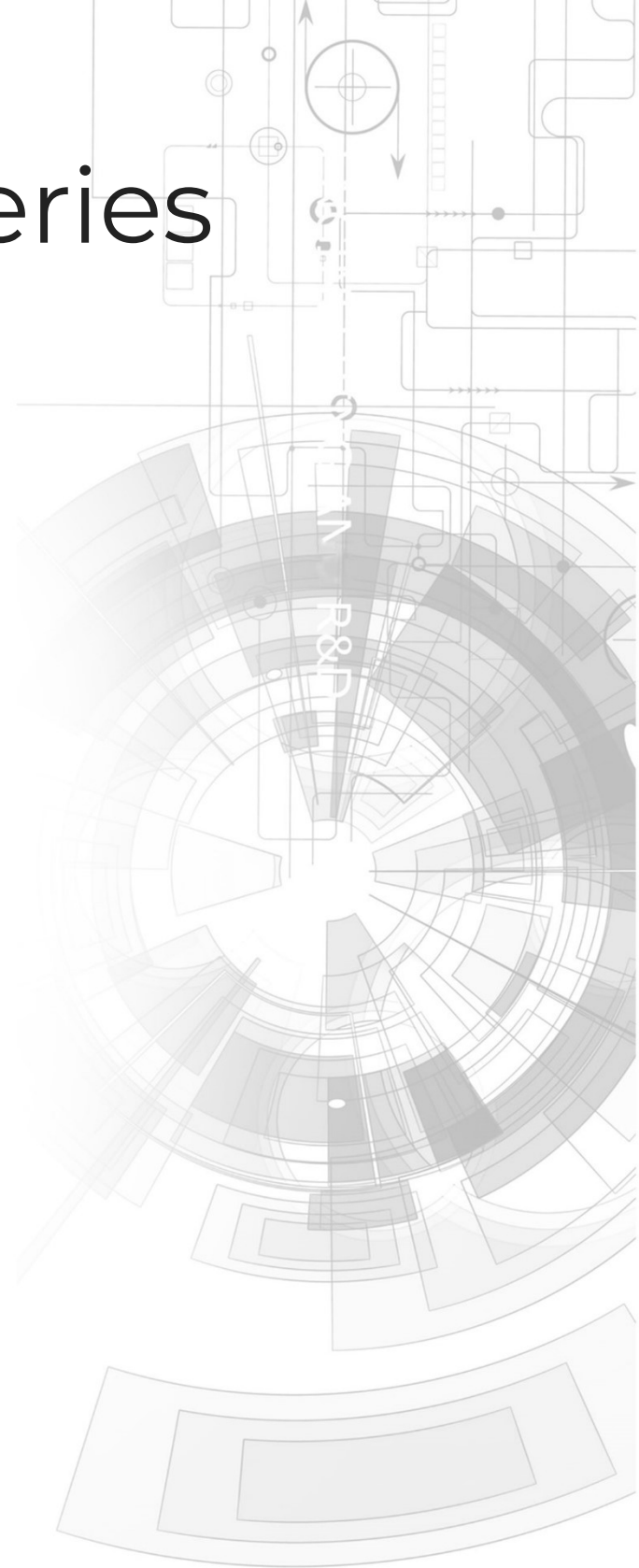

# Contents

---

1. Description	3
2. Features	4
3. Getting Started	5
3.1. Requirements	5
3.2. How to Use the 4DCAPE	5
3.3. Changing the Brightness (Debian)	6
3.4. Changing the Brightness (Android)	6
3.5. Android Information	6
3.6. Calibrating Resistive Touch (Debian)	6
4. EEPROM Details	8
5. Display Precautions	9
6. Software / Driver Disclaimer	10
7. Schematic Diagram 1.1	11
8. Schematic Diagram 1.3	12
9. Schematic Diagram 1.4	13
10. Mechanical Details	14
11. Specifications	15
12. Ordering Information	17
13. Revision History	18

# 1. Description

The 4D 4.3" LCD CAPE is a cape specifically designed for the Beagle Bone Black (BBB), and provides a 4.3" primary display for the BBB for direct user interaction and information display.

Available in both Resistive Touch (4DCAPE-43T) and non-touch (4DCAPE-43) via a special request - the non-touch version may be subject to MOQ.

The 4DCAPE is **not** compatible with the previous Beagle Bone (Beagle Bone White) and can only be used with the Beagle Bone Black.

The 4D 4.3" LCD CAPE features a 4.3" TFT LCD 480x272 resolution display.

The 4DCAPE uses the drivers developed for existing LCD CAPES, where drivers are built into the Kernel of the OS. 4D Systems does not provide drivers.

The Beagle Bone Black connects directly to the back of the 4DCAPE and provides everything the CAPE requires such as power and display signals.

The 4D 4.3" LCD CAPE features 7 push buttons below the screen, LEFT, RIGHT, UP, DOWN, ENTER, RESET and POWER, along with 2 LEDs to indicate Power and User Status (normally heartbeat).

Mounting of the 4DCAPE is achieved with the 4x 3.5mm mounting holes present on the CAPE, enabling standard M3 or #6-32 screws to fasten the 4DCAPE-43 as required.



## 2. Features

- 4.3" TFT LCD CAPE for the Beagle Bone Black
- Available in 2 models, Resistive Touch (4DCAPE-43T) and non-Touch (43CAPE-43)
- 7 push buttons including LEFT, RIGHT, UP, DOWN, ENTER, RESET and POWER
- 2 LED Lights for Power and User
- 2x2 Jumper with shunts for EEPROM CAPE ID selection
- Module dimensions: 120.4 x 80.0 x 24.8mm
- Module dimensions with Beagle Bone Black connected: Approx 120.4 x 80.0 x 32.0mm
- 4x 3.5mm Mounting holes.
- RoHS and CE Compliant.

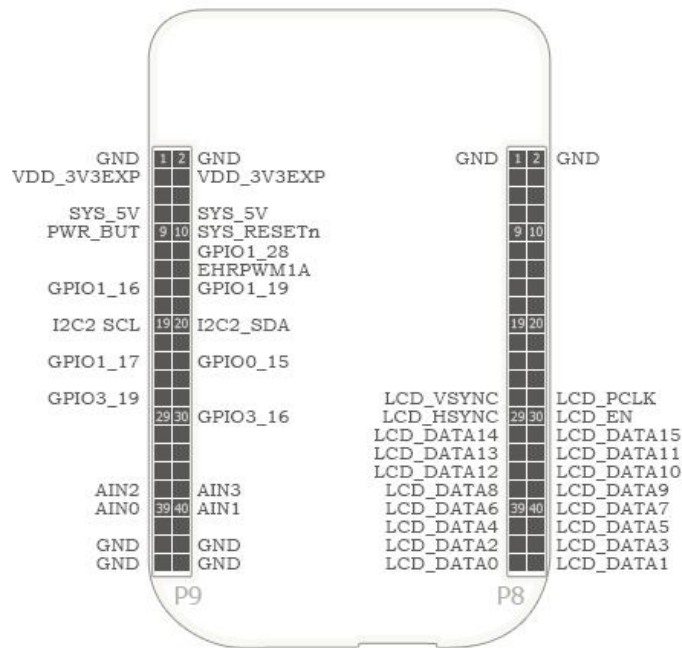
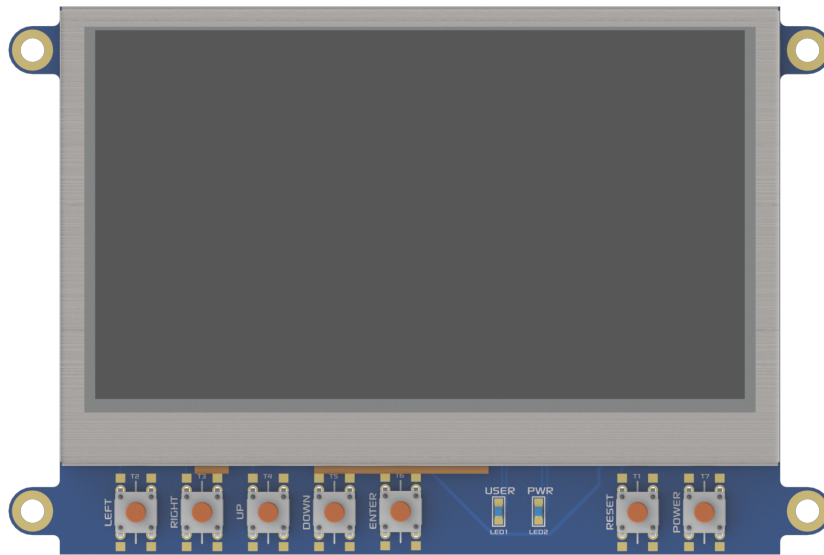

## 3. Getting Started

### 3.1. Requirements

The 4D 4.3" LCD CAPE is designed to work with existing software and drivers already developed for LCD CAPES for the Beagle Bone Black.

The Requirements for use are:

- 4DCAPE-43 or 4DCAPE-43T
- Beagle Bone Black (BBB) with suitable distribution loaded.
- 5V DC Supply suitable for the Beagle Bone Black, recommended 2A @ 5V.
- A Stylus is recommended for accurate touch, however, is not required.

### 3.2. How to Use the 4DCAPE

The following steps should be all that is required to use the 4DCAPE:

1. Connect the 4DCAPE to the Beagle Bone Black while the Beagle Bone Black is not powered. The outline of the BBB is printed on the back of the 4DCAPE as a guide for orientation.
2. If using with other capes, ensure the 4DCAPE-43 is not conflicting pin-wise with any other cape installed.
3. Ensure the EEPROM ID Jumper on the CAPE is set to a different EEPROM ID than any other capes. See the [EEPROM Details](#) section.
4. Ensure your Beagle Bone Black is loaded with a suitable Linux distribution that is compatible with LCD CAPES or 4D Systems 4DCAPEs - See the [Display Precautions](#) section. Debian is the distribution shipping with current BBB boards now and can be installed onto older BBBs. Many distributions exist, both Linux and Android. Select one that suits your needs.
5. Connect a 5V Supply to the DC Jack of the Beagle Bone Black. It is recommended to use a 2A supply to ensure sufficient supply.
6. Once power is connected, something should be displayed on the 4DCAPE as it is booted. Each distribution will behave differently and require different input from the User. It is recommended to have a keyboard attached while setting the system up, as login details etc may be required. Some distributions may prompt for LCD calibration, while others may prompt for Username/ Password.

For support of the BBB and various distributions, please seek support from the respective websites associated with the BBB itself or the distributions.

A good place to start for information and support regarding the BBB and various distributions available is <https://www.beagleboard.org>

This website details the latest firmware images for the BBB: <https://beagleboard.org/latest-images>

This website details how to get started with the BBB: <https://beagleboard.org/getting-started>

For support regarding the 4DCAPE hardware itself, please go to the 4D Systems website and either contact Support directly via a Ticket or use the [4D Systems Forum](#).

### 3.3. Changing the Brightness (Debian)

It is possible to change the backlight brightness as the backlight is PWM controlled.

Please note, these instructions may become obsolete as new versions of Debian are released, or if different distributions are used.

One method is to SSH into the Beaglebone Black from your PC and set the backlight value that way. Note this does not persist over restarts, so this would need to be entered into a start-up script if the setting is required to be set for each start-up.

At the command prompt, type the following:

```
$ sudo su
# cd /sys/class/backlight/backlight
# echo 50 > brightness
```

Where 50 represents 50%, this can be changed to any number from 0 to 100 as required.

The exact path may vary with distributions, so check the `/sys/class/backlight` path to see what backlight file exists.

### 3.4. Changing the Brightness (Android)

Changing the brightness on Android is simple. Navigate to the Settings menu, to the Display option, and then to Brightness. Slide the slider to the desired position.

### 3.5. Android Information

The 4DCAPE is compatible with Android 4.2.2 and has been tested with an image from TI.

It has been noticed however that the EEPROM Jumpers both need to be connected/closed otherwise the 4DCAPE may not be detected by the Android OS.

### 3.6. Calibrating Resistive Touch (Debian)

When a distribution is used for the first time with a 4DCAPE, often an LCD calibration application will start automatically. However, depending on the distribution in use, this may or may not happen. Some distributions may not even come with a calibration application loaded.

For ones that do have the calibration program loaded by default, and if the calibration is input incorrectly and it is required to be set again, it can generally be started from the 'Start' menu.

 **Note**

- This may change as newer distributions become available, or if different distributions are used, so these instructions may become obsolete or inaccurate.
- The Beaglebone, Beaglebone Black and Beagleboard remain the property of beaglebone.org. All references to the words Beaglebone, Beaglebone Black, and Beagleboard are licensed under a Creative Commons Attribution-Share Alike 3.0 license.
- All references to CircuitCo and LCD4 remain the property of CircuitCo and beagleboardtoys.org and are not affiliated with 4D Systems in any way.

## 4. EEPROM Details

On the 4D 4.3" LCD CAPE there is an EEPROM which is used to configure the Beagle Bone Black with the appropriate configuration to use the Cape.

Depending on if the board is a 4DCAPE-43 or a 4DCAPE-43T the EEPROM contents will vary slightly.

### • 4DCAPE-43 EEPROM

EEPROM Support: YES

Board Name: 4D 4.3 LCD CAPE - 4DCAPE-43

Manufacturer: 4D Systems

### • 4DCAPE-43T EEPROM

EEPROM Support: YES

Board Name: 4D 4.3 LCD CAPE - 4DCAPE-43T

Manufacturer: 4D Systems

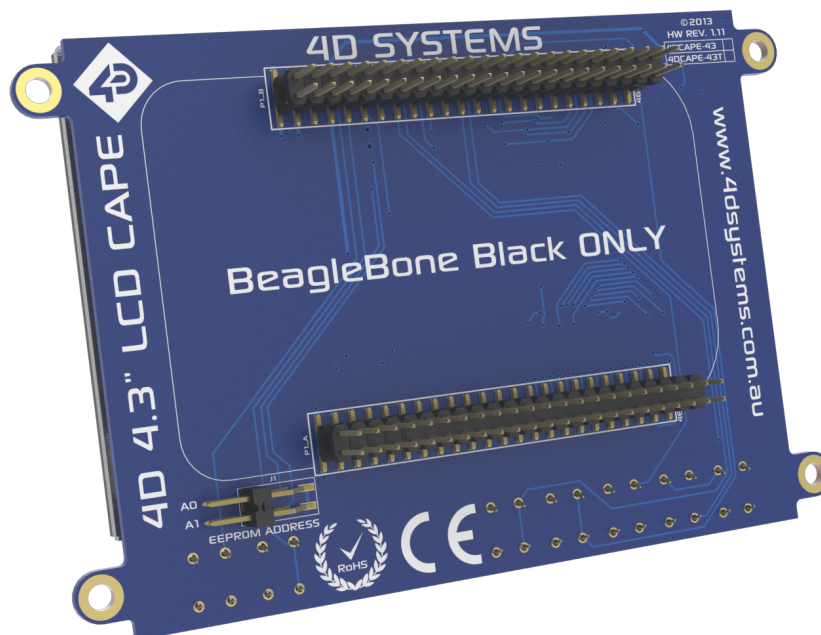

#### Note

Some EEPROM content refers to the LCD4 which is made by CircuitCo. This is the case due to how the BBB identifies the CAPE and what drivers to apply to it. Since the 4DCAPE-43T uses the LCD4 drivers, this must be the case.



## 5. Display Precautions

- Avoid having to display the same image/object on the screen for lengthy periods. This will cause a burn-in which is a common problem with all types of display technologies. Blank the screen after a while or dim it very low by adjusting the contrast. Better still, implement a screen saver feature.
- Moisture and water can damage the display. Moisture on the surface of a powered display will cause the electrodes to corrode. Wipe off any moisture gently or let the display dry before usage.
- Dirt from fingerprint oil and fat can easily stain the surface of the display. Gently wipe off any stains with a soft lint-free cloth.
- The performance of the display will degrade under high temperatures and humidity. Avoid such conditions when storing.
- Do not tamper with the display flex cable that is connected to the control board. This may affect the connection between the display and the driving circuitry and cause failure. Under no circumstances should the display flex be disconnected from the PCB and power applied to the PCB, as this could result in the instant failure of the CAPE.
- Displays are susceptible to mechanical shock and any force exerted on the module may result in deformed zebra stripes, a cracked display cell and broken backlight.
- Always use the mounting holes on the module to mount the display.
- Remove the BBB from the 4DCAPE carefully when required to remove the BBB, as the headers on the 4DCAPE are SMT and excessive force or rough removal could break solder joints and connections. Carefully wiggle the BBB off the 4DCAPE if you require to remove the BBB from the cape once installed.

## 6. Software / Driver Disclaimer

4D Systems has developed this 4DCAPE for the Beaglebone Black. 4D Systems does NOT support any software associated with the BBB itself, as 4D Systems is not involved with the development or support of the BBB Operating Systems. It is up to the user to determine which distributions are used on the BBB, and therefore which are compatible with this CAPE. 4D Systems will supply the source code for the 4DCAPE, which is installed on the Debian Distribution for the BBB by default, however, the source can be used if Users wish to use another operating system. It will however be up to the User to get this operational. Assistance can be provided on our [Forum](#)

4D Systems has been made aware that there may be touch-related issues with the Angstrom Distribution (Possibly others based on the same issue source) of Linux, and the mouse may appear to 'self-touch' or jump around the screen on touch, or generally behave erratically. Since 4D Systems has not developed nor supported anything to do with the software associated with this hardware, 4D Systems is unable to assist or offer support regarding this matter. **A Fixed Kernel is now available, 3.8.13-bone37 while solving this issue** This Kernel is available via the Debian download which is linked on our Product Page. This issue was fixed in 2013, so all current distributions should already contain this fix - however, this is not guaranteed.

The Android distribution listed in this document does not feature this erratic touch behaviour and effectively illustrates the issues are software or driver related, and not hardware.

If these issues are encountered, it is encouraged to try the Android distribution to verify it is not a hardware issue. If the issue remains, please contact 4D Systems Technical Support. If the issue is no longer present and the touch works correctly on Android, then please contact the [beaglebone.org](http://beaglebone.org) community.

The 4DCAPE-43T uses drivers which have been written for other devices on the market and the hardware is set up similarly. Drivers for the Circuitco LCD4 are used for this CAPE and therefore if fixes are made to improve compatibility with the LCD4, they should also function correctly for the 4DCAPE-43T.

4D Systems is not responsible for issues regarding software or drivers associated with the BBB and the compatibility with this product. Community Software support is available via resources at [www.beaglebone.org/discuss](http://www.beaglebone.org/discuss).

# 7. Schematic Diagram 1.1

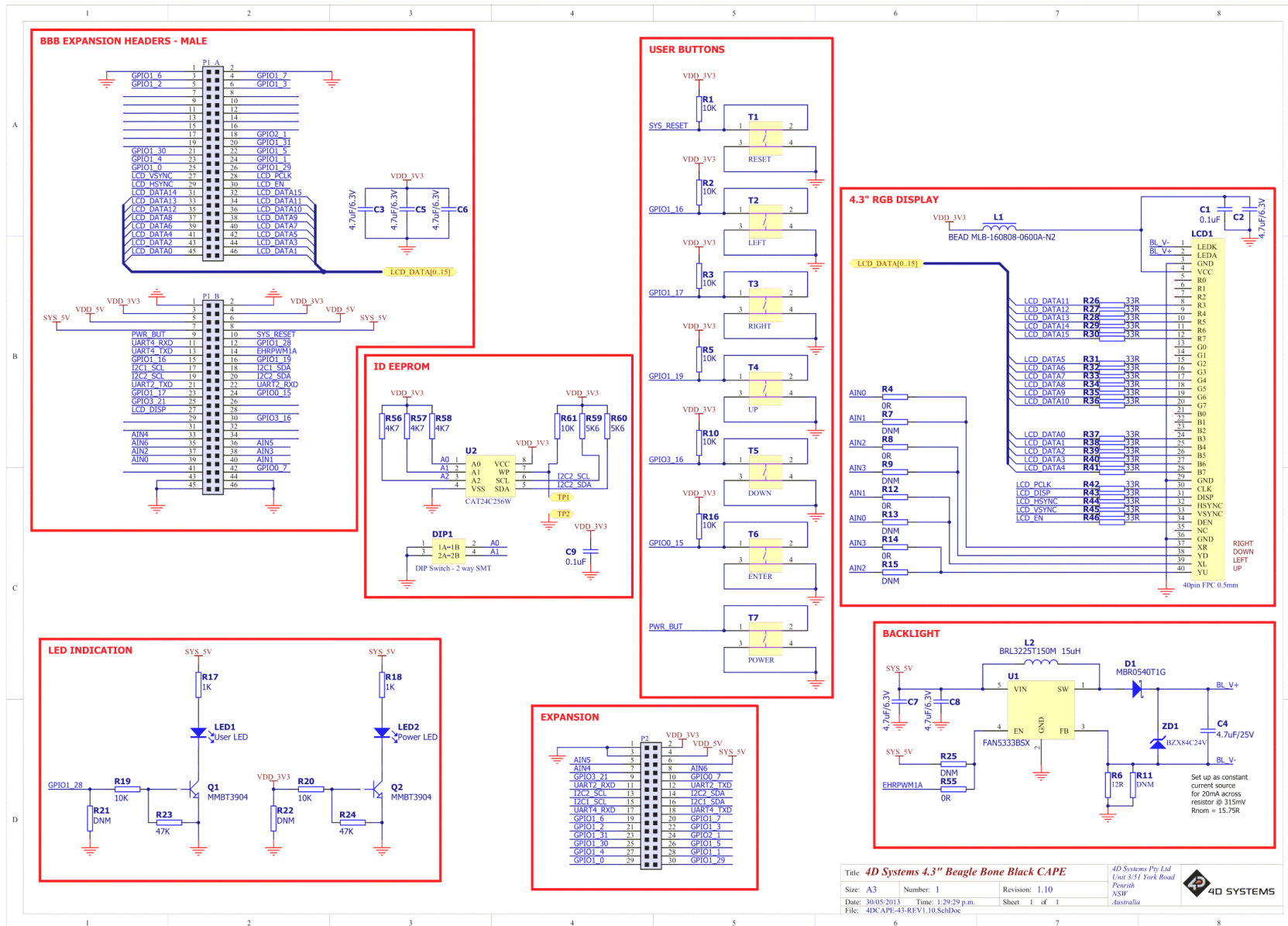

# 8. Schematic Diagram 1.3

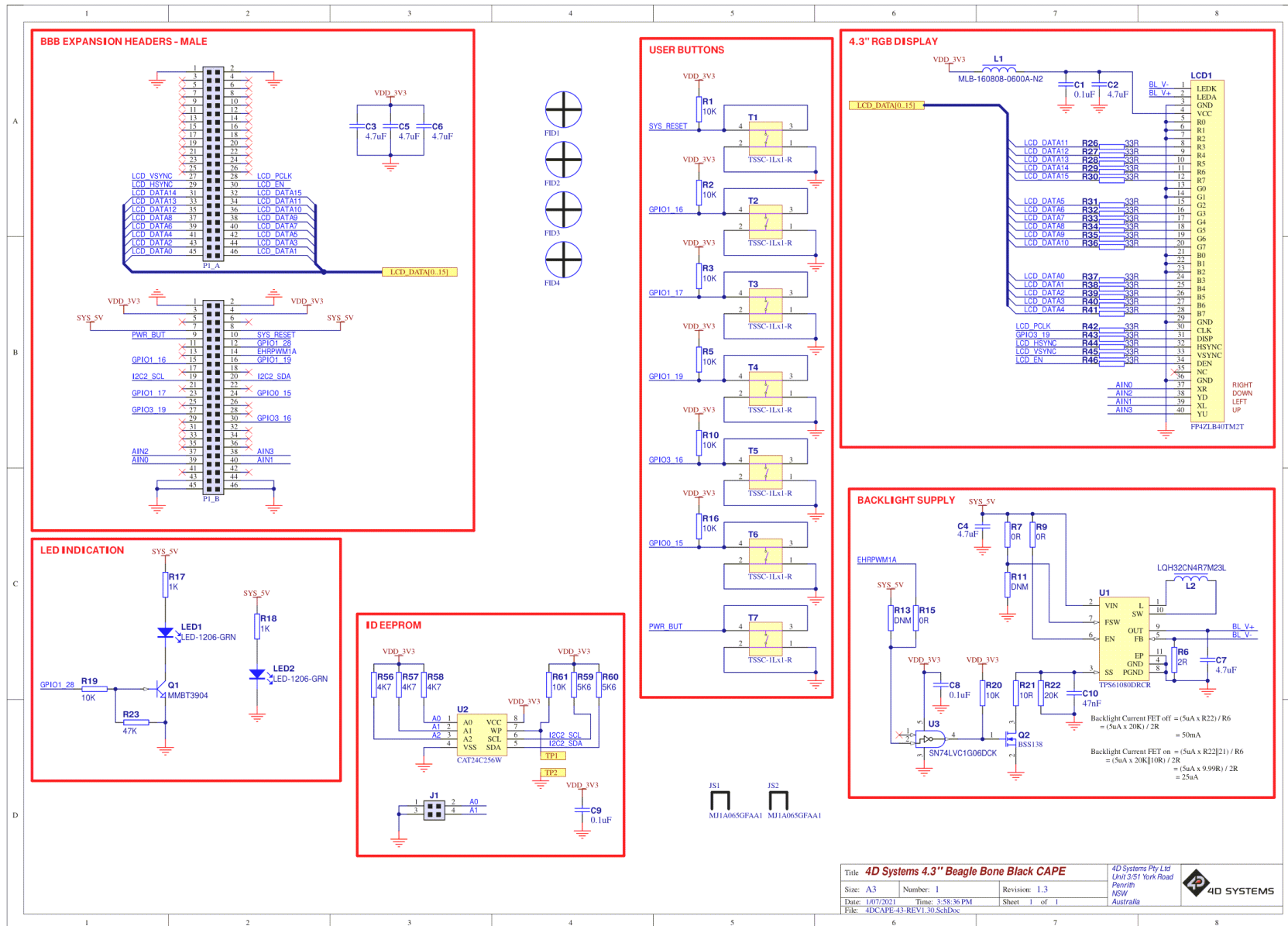

Title: <b>4D Systems 4.3" Beagle Bone Black CAPE</b>		4D Systems Pty Ltd Unit 5/21 York Road Penrith NSW Australia	
Size: A3	Number: 1	Revision: 1.3	
Date: 10/7/2021	Time: 3:58:36 PM	Sheet 1 of 1	
File: 4DCAPE-43-REV1.30.SchDoc			



# 10. Mechanical Details

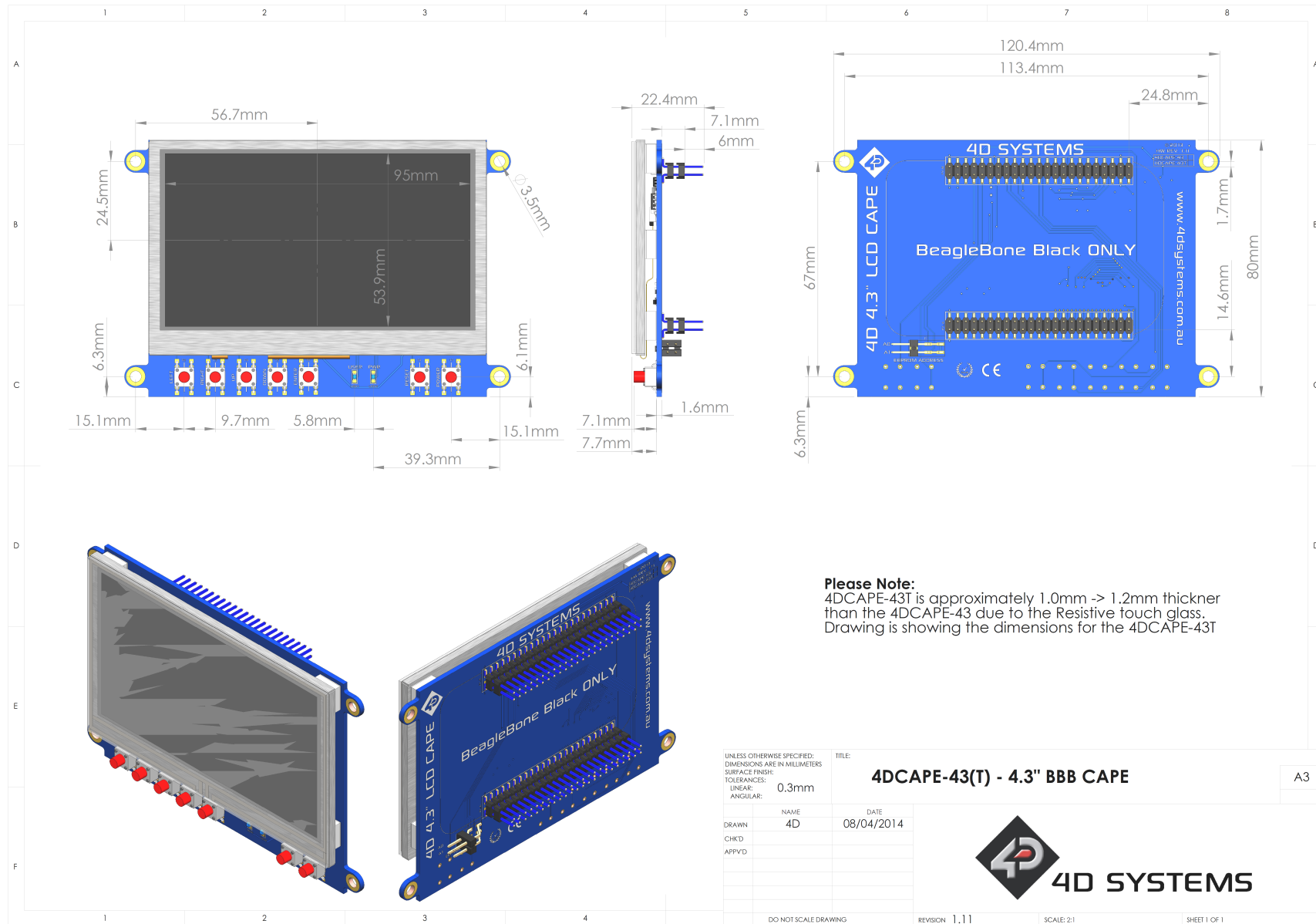

## 11. Specifications

### Absolute Maximum Ratings

Operating ambient temperature	-20°C to +70°C
Storage temperature	-30°C +80°C

### Note

Stresses above those listed here may cause permanent damage to the device. This is a stress rating only and functional operation of the device at those or any other conditions above those indicated in the recommended operation listings of this specification is not implied. Exposure to maximum rating conditions for extended periods may affect device reliability.

### Global Characteristics Based on Operating Conditions

Parameter	Conditions	Min	Typ	Max	Units
Supply Current (5V bus of BBB) <b>(INCLUDES POWER BBB USES ALSO)</b>	4DCAPE-43 (Max Brightness)	--	590	--	mA
Supply Current (5V bus of BBB) <b>(INCLUDES POWER BBB USES ALSO)</b>	4DCAPE-43T (Max Brightness)	--	600	--	mA
Display Endurance	Hours of operation, measured to when display is 50% original brightness	30000	--	--	H
Touch Screen Endurance (Resistive Touch)	Number of touches/hits with a 12.5mm tip at a rate of 2x per second with 250gf force	--	1M	--	Touches
Touch Screen Endurance (Resistive Touch)	Slide stylus on screen, 100gf force, 60mm/s speed with a 0.8mm polyacetal tip stylus pen	--	100K	--	Slides
Touch Screen Transparency	Resistive Touch	82	--	--	%
Touch Screen Operational Force (Resistive Touch)	Only use Finger or Stylus, do not use anything sharp or metal	20	--	100	Gf

 **LCD Display Information - TN**

Parameter	Conditions	Specification
Display Type	All displays produced before IPS release date in IPS table below, or any modules not specified are therefore TN type displays	<b>TN</b> - TFT Transmissive LCD
Display Sizes		4.3", 5.0" or 7.0" Diagonal
Display Resolution		480x272 (Landscape Viewing) 4.3" 800x480 (Landscape Viewing) 5" & 7"
Display Brightness	4DCAPE-43 (Max Brightness)	500 cd/m2
Display Brightness	4DCAPE-43T (Max Brightness)	400 cd/m2
Display Contrast Ratio	Typical	500:1
Display Viewing Angles	Above Centre	70 Degrees
	Below Centre	60 Degrees
	Left of Centre	70 Degrees
	Right of Centre	70 Degrees
Display Viewing Direction	TN Display (Landscape/Wide mode)	12 o'clock Display
Display Backlighting	4DCAPE-43xx Models	2x5 Parallel LEDs
Pixel Pitch	4.3"	0.198 x 0.198mm (Square pixels)
Pixel Density	4.3"	128 DPI/PPI



### LCD Display Information - IPS

Parameter	Conditions	Specification
Display Type	<b>4DCAPE-43</b> – Modules produced March 2021 onwards <b>4DCAPE-43T</b> – Modules produced March 2021 onwards	<b>IPS</b> - TFT Transmissive LCD
Display Sizes		4.3", 5.0" or 7.0" Diagonal
Display Resolution		480x272 (Landscape Viewing) 4.3" 800x480 (Landscape Viewing) 5" & 7"
Display Brightness	4DCAPE-43 (Max Brightness)	600 cd/m <sup>2</sup>
Display Brightness	4DCAPE-43T (Max Brightness)	510 cd/m <sup>2</sup>
Display Contrast Ratio	Typical	800:1
Display Viewing Angles	Above, Below, Left and Right of Centre	80 Degrees
Display Viewing Direction	IPS Displays	ALL (Viewing from all directions)
Display Backlighting	4DCAPE-43xx Models	2x5 Parallel LEDs
Pixel Pitch	4.3"	0.198 x 0.198mm (Square pixels)
Pixel Density	4.3"	128 DPI/PPI

## 12. Ordering Information

### ORDERING INFORMATION

#### Order Code:

4DCAPE-43 (Non-Touch)

4DCAPE-43T (Resistive Touch)

**Packaging:** Module sealed in antistatic foam padded 4D Systems Box