

# 4DLCD-28QA

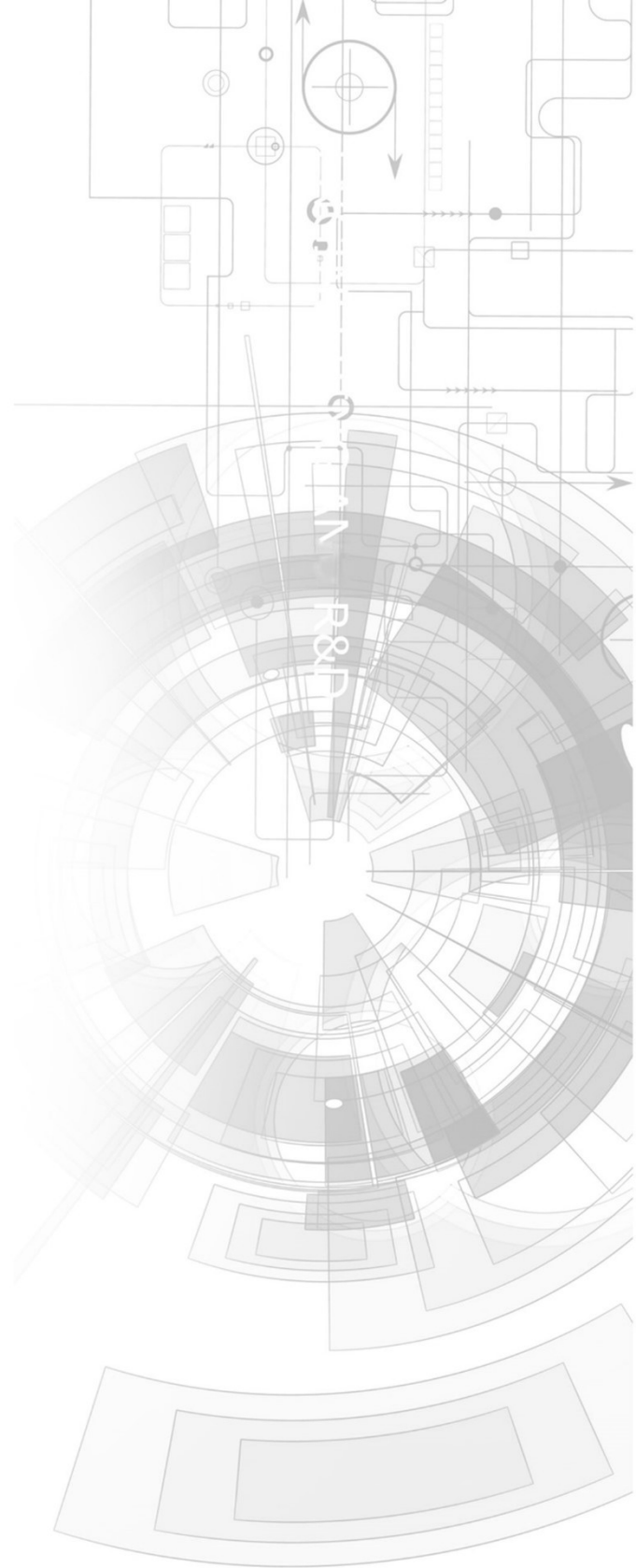

## Datasheet

Revision 1.1

Copyright © 2023 4D Systems

Content may change at any time. Please refer to the resource centre for latest documentation.

# Contents

---

|  |    |
|--|----|
| 1. Specifications                          | 3  |
| 1.1. Mechanical Specifications             | 4  |
| 1.2. Pin Descriptions                      | 5  |
| 2. Electrical Specifications               | 7  |
| 2.1. Absolute Maximum Ratings              | 7  |
| 2.2. DC Characteristics                    | 7  |
| 2.3. LED Backlight Maximum Ratings         | 8  |
| 2.4. LED Backlight Optical Characteristics | 8  |
| 3. Optical Characteristics                 | 9  |
| 4. Touch Characteristics                   | 11 |
| 5. Initialisation Codes                    | 12 |
| 5.1. Command Definitions                   | 12 |
| 5.2. Init Code                             | 13 |
| 6. Quality Testing                         | 14 |
| 6.1. Reliability Test                      | 14 |
| 7. Precautions for Using LCD Modules       | 16 |
| 7.1. Handling Precautions                  | 16 |
| 7.2. Storage Precautions                   | 18 |
| 8. Using LCD Modules                       | 19 |
| 8.1. Installing LCD Modules                | 19 |
| 8.2. Precautions for Operation             | 20 |
| 8.3. Safety                                | 20 |
| 8.4. Return LCM under Warranty             | 21 |
| 9. Revision History                        | 22 |

# 1. Specifications

|  General Specifications |                       |                                |
|--|-----------------------|--------------------------------|
| S.No.  | Items                 | Specifications                 |
| 1  | Screen size (inch)    | 2.8" Diagonal                  |
| 2  | LCD Type              | TFT, Positive, TRANSMISSIVE    |
| 3  | Colors                | 65K Color                      |
| 4  | Display Resolution    | 240 x RGB x 320                |
| 5  | Module Outline (mm)   | 50 x 69.2 x 3.6 (W x H x T)    |
| 6  | Active Area (mm)      | 43.2 x 57.6 (W x H)            |
| 7  | Touch Panel Dimension | 49.5 x 68.75 x 1.2 (W x H x T) |
| 8  | Viewing Direction     | 6:00 O' Clock                  |
| 9  | Pixel Arrangement     | RGB Vertical Stripe            |
| 10   | Interface             | 8080, 8/16 bit CPU Interface   |
| 11   | Assembly Type         | Connector type FPC             |
| 12   | Driver IC             | ILI9341                        |
| 13   | Backlight             | 4 x White LED                  |
| 14   | Pixel Arrangement     | RGB Vertical Stripe            |

### 1.1. Mechanical Specifications

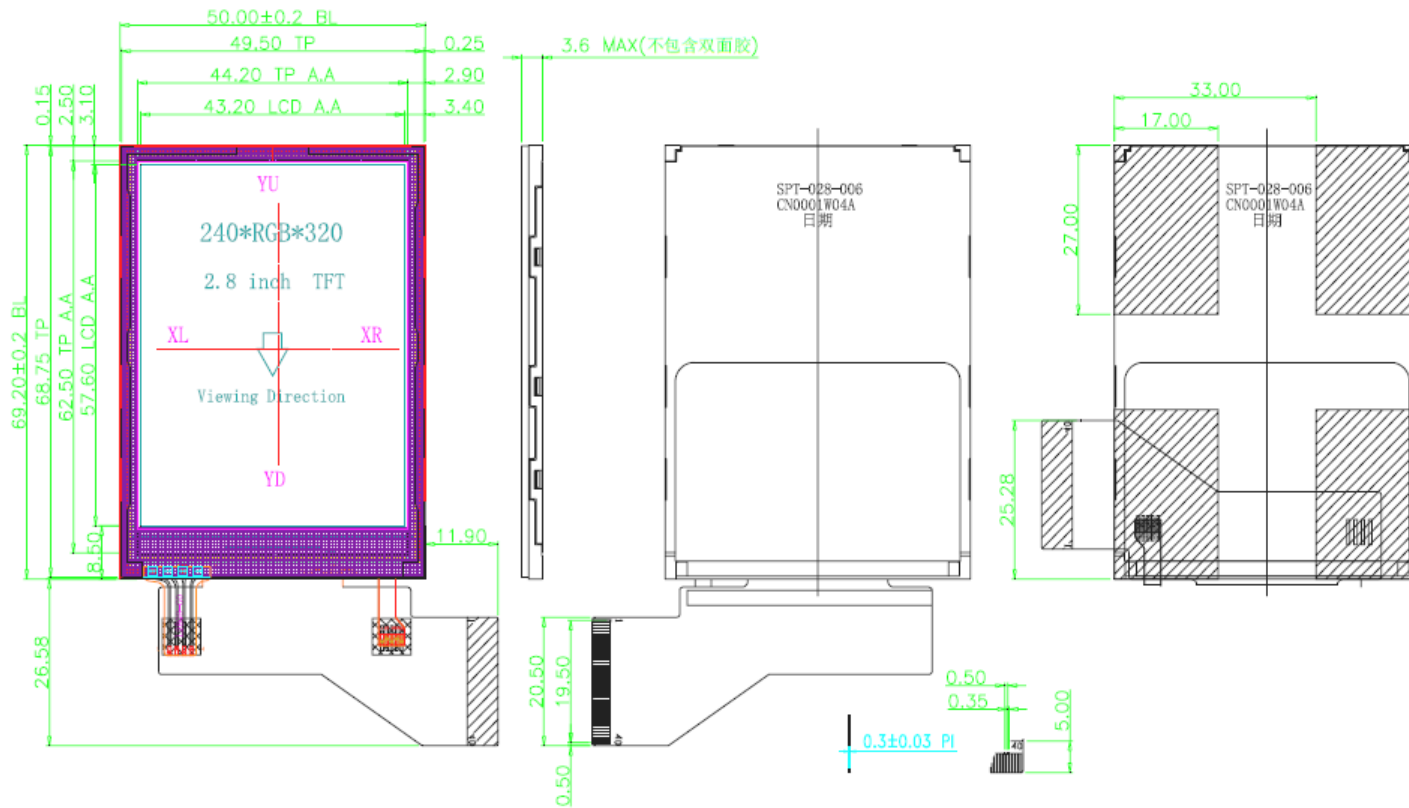

| PIN | ASSIGNMENT | PIN | ASSIGNMENT |
|-----|------------|-----|------------|
| 1   | GND        | 26  | DB1        |
| 2   | GND        | 27  | DB2        |
| 3   | IM0(B/16)  | 28  | DB3        |
| 4   | FMARK      | 29  | DB4        |
| 5   | YD         | 30  | DB5        |
| 6   | XL         | 31  | YU         |
| 7   | RESET      | 32  | XR         |
| 8   | RS         | 33  | LEDA       |
| 9   | CS         | 34  | LEDK1      |
| 10  | RD         | 35  | LEDK2      |
| 11  | WR         | 36  | LEDK3      |
| 12  | VCC=3.3V   | 37  | LEDK4      |
| 13  | NC         | 38  | NC         |
| 14  | GND        | 39  | NC         |
| 15  | DB15       | 40  | GND        |
| 16  | DB14       |     |            |
| 17  | DB13       |     |            |
| 18  | DB12       |     |            |
| 19  | DB11       |     |            |
| 20  | DB10       |     |            |
| 21  | DB9        |     |            |
| 22  | DB8        |     |            |
| 23  | DB7        |     |            |
| 24  | DB6        |     |            |
| 25  | DB0        |     |            |

## 1.2. Pin Descriptions

| Pin   | Symbol     | I/O     | Function  |
|-------|------------|---------|---|
| 1     | GND        | Power   | Ground  |
| 2     | GND        | Power   | Ground  |
| 3     | IMO(8/16)  | Control | Interface Mode<br>0: for 16bit Mode<br>1: for 8bit Mode |
| 4     | FMARK      | Control | Output a frame head pulse signal                        |
| 5     | Y- (YD)    | INPUT   | Touch Panel Y   |
| 6     | X+ (XL)    | INPUT   | Touch Panel X   |
| 7     | RESET      | INPUT   | A Reset Signal  |
| 8     | RS         | INPUT   | A Register select signal                                |
| 9     | CS         | INPUT   | A Chip select signal                                    |
| 10    | RD         | INPUT   | Read signal   |
| 11    | WR         | INPUT   | Write signal  |
| 12    | VCC        | Power   | 3.3V: Analog Power Supply                               |
| 13    | NC         | -       | Not Connected   |
| 14    | GND        | Power   | Ground  |
| 15~22 | DB15~ DB08 | I/O     | Parallel interface data bus                             |
| 23    | DB7        | I/O     | Parallel interface data bus                             |
| 24    | DB6        | I/O     | Parallel interface data bus                             |
| 25    | DB0        | I/O     | Parallel interface data bus                             |
| 26    | DB1        | I/O     | Parallel interface data bus                             |
| 27    | DB2        | I/O     | Parallel interface data bus                             |
| 28    | DB3        | I/O     | Parallel interface data bus                             |
| 29    | DB4        | I/O     | Parallel interface data bus                             |
| 30    | DB5        | I/O     | Parallel interface data bus                             |
| 31    | Y+(YU)     | INPUT   | Touch Panel Y   |
| 32    | X- (XR)    | INPUT   | Touch Panel X :   |
| 33    | LEDA       |         | LED Anode   |
| 34    | LEDK1      |         | LED cathode   |

---

| <b>Pin</b> | <b>Symbol</b> | <b>I/O</b> | <b>Function</b> |
|------------|---------------|------------|-----------------|
| 35         | LEDK2         |            | LED cathode     |
| 36         | LEDK3         |            | LED cathode     |
| 37         | LEDK4         |            | LED cathode     |
| 38         | NC            | -          | Not Connected   |
| 39         | NC            | -          | Not Connected   |
| 40         | GND           |            | Power Ground    |

## 2. Electrical Specifications

### 2.1. Absolute Maximum Ratings

| Absolute Maximum Ratings |               |                             |      |                |                    |
|--------------------------|---------------|-----------------------------|------|----------------|--------------------|
| Items                    | Symbol        | Condition                   | Min. | Max.           | Unit               |
| Power supply Voltage     | $V_{CI}$      | $T_a = +25^{\circ}\text{C}$ | -0.3 | +4.6           | V                  |
|                          | $V_{GH\_VSS}$ |                             | -0.3 | +18.5          | V                  |
|                          | $V_{SS\_VGL}$ |                             | -0.3 | +18.5          | V                  |
| Input Voltage            | $V_{in}$      |                             | -0.3 | $V_{CI} + 0.3$ | V                  |
| Operating Temperature    | $T_{OP}$      | -                           | -20  | +70            | $^{\circ}\text{C}$ |
| Storage Temperature      | $T_{ST}$      | -                           | -30  | +80            | $^{\circ}\text{C}$ |
| Storage Humidity         | $H_D$         | -                           | 20   | 90             | %RH                |

#### Caution

Any stresses exceeding the absolute Maximum Ratings may cause substantial damage to the device.

### 2.2. DC Characteristics

| DC Characteristics   |          |                             |             |      |             |
|----------------------|----------|-----------------------------|-------------|------|-------------|
| Items                | Symbol   | Conditions                  | Min.        | Typ. | Max.        |
| Power supply voltage | $V_{CI}$ | $T_a = +25^{\circ}\text{C}$ | 2.6         | 2.8  | 3.0         |
| Input High Voltage   | $V_{IH}$ |                             | $0.8V_{CI}$ | -    | $V_{CI}$    |
| Input Low Voltage    | $V_{IL}$ |                             | -0.3        | -    | $0.2V_{CI}$ |
| Output High Voltage  | $V_{OH}$ |                             | $0.8V_{CI}$ | -    | $V_{CI}$    |
| Output Low Voltage   | $V_{OL}$ |                             | -           | -    | $0.2V_{CI}$ |

## 2.3. LED Backlight Maximum Ratings

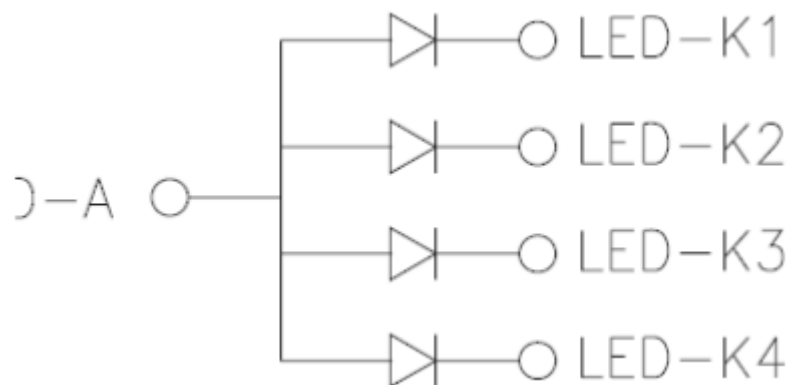

### LED Backlight Maximum Ratings

| Items             | Symbol | Conditions                | Min. | Typ. | Max. |
|-------------------|--------|---------------------------|------|------|------|
| Forward Current   | $I_F$  | $T_a = +25^\circ\text{C}$ | -    | -    | 60   |
| Forward Voltage   | $V_F$  |                           | -    | -    | 3.5  |
| Power Dissipation | $P_D$  |                           | -    | -    | 210  |

## 2.4. LED Backlight Optical Characteristics

### LED Backlight Optical Characteristics

| Items                            | Symbol | Conditions                | Min. | Typ. | Max. |
|----------------------------------|--------|---------------------------|------|------|------|
| Forward Voltage                  | $V_F$  | $I_F = 60\text{mA}$       | 2.8  | 3.2  | 3.5  |
| Average Brightness (without LCD) | $I_V$  | $V_F = 3.2\text{V}$       | 3500 | -    | -    |
| Chromaticity Coordinates         | X      | 4 x White LEDs            | 0.26 | -    | 0.31 |
|                                  | Y      | $T_a = +25^\circ\text{C}$ | 0.26 | -    | 0.31 |
| Color                            | White  |                           |      |      |      |



### 3. Optical Characteristics

Optical characteristics are determined after the unit has been 'ON' and stable for approximately 30min in a dark environment at 25°C.

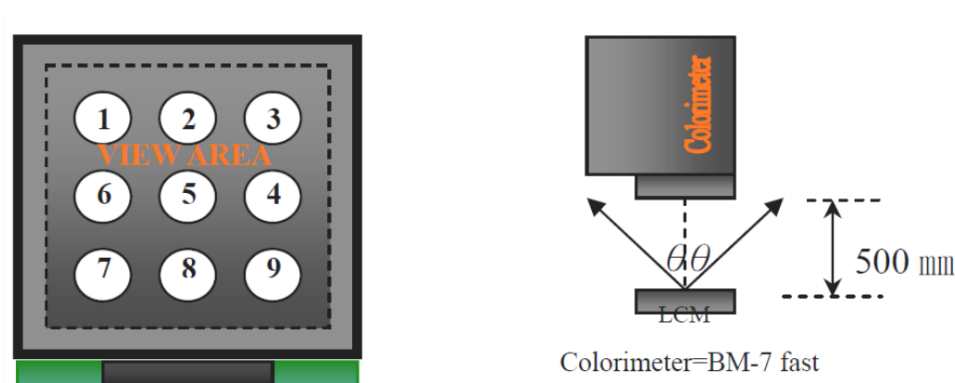

*Optical Characteristic Measurement and Method*

The values specified are at an approximate distance of 50cm from the TFT-LCD surface at a viewing angle of  $\theta = \Phi = 0^\circ$ . VCC = 2.8V

| Optical Characteristics                              |            |   |       |       |       |
|--|------------|---|-------|-------|-------|
| Item   | Symbol     | Condition                                     | Min   | Typ   | Max   |
| Contrast ratio                                       | Cr         |   | -     | 250   | -     |
| Response time  | Tr+Tf      | Ta = +25°C<br>$\theta_x = \theta_y = 0^\circ$ | -     | 30    | -     |
| Color Filter chromaticity                            | Red x      | Ta = +25°C<br>$\theta_x = \theta_y = 0^\circ$ | 0.606 | 0.626 | 0.646 |
|  | Red y      |   | 0.314 | 0.334 | 0.354 |
|  | Green x    |   | 0.257 | 0.277 | 0.297 |
|  | Green y    |   | 0.529 | 0.549 | 0.569 |
|  | Blue x     |   | 0.122 | 0.142 | 0.162 |
|  | Blue y     |   | 0.102 | 0.122 | 0.142 |
|  | White x    |   | 0.283 | 0.303 | 0.323 |
|  | White y    |   | 0.305 | 0.325 | 0.345 |
| Average Brightness<br>Pattern = white display (main) | Iv         | IF = 60mA                                     | -     | 150   | -     |
| Uniformity   | $\Delta B$ | IF = 60mA                                     | 80    | -     | -     |

**Note**

1.  $\Delta B = B(\text{min}) / B(\text{max}) \times 100\%$
2. Measurement Condition for Optical Characteristics:
  - a. Environment:  $25^{\circ}\text{C} \pm 5^{\circ}\text{C} / 60 \pm 20\% \text{R.H}$  no wind, dark room below 10 Lux with a typical lamp.
  - b. Current and typical operating frequency.
  - c. Measurement Distance:  $500 \pm 50\text{mm}$ , ( $\theta = 0^{\circ}$ ).
  - d. Equipment: TOPCON BM-7 fast, (field  $1^{\circ}$ ), after 10 minutes of operation.
  - e. The uncertainty of the C.I.E coordinate measurement  $\pm 0.01$ , Average Brightness  $\pm 4\%$

**Response time**

The output signals of the photodetector are measured when the input signals are changed from "black" to "white" (falling time) and from "white" to "black" (rising time), respectively. The response time is defined as the time interval between 10% and 90% of Amplitudes.

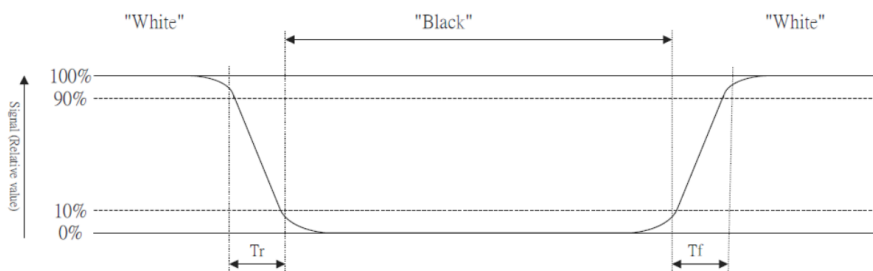
**Contrast ratio**

$$\text{Contrast Ratio (CR)} = \frac{\text{Photo detector output when LCD is at "White" state}}{\text{Photo detector output when LCD is at "Black" state}}$$

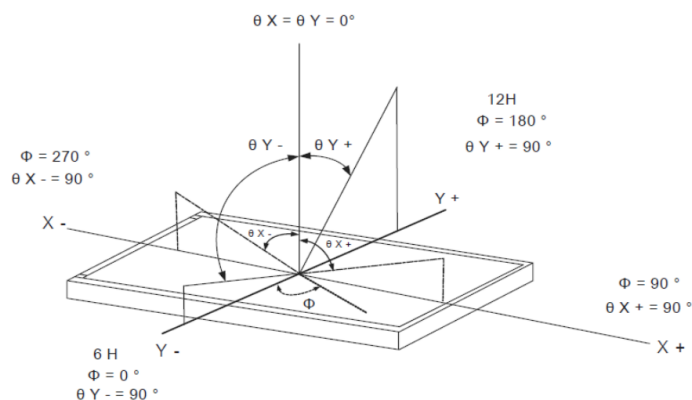
**Viewing angle****Note**

The Screens used are the highest rated '**Grade A**' Displays which allow for 0-4 defective pixels. A defective pixel could be solid Black (Dead), Red, Green or Blue. 4D Systems is not liable for a return/replacement for any Display that has 4 or fewer defective pixels.

## 4. Touch Characteristics

| Touch Parameters               |                            |      |     |     |         |
|--------------------------------|----------------------------|------|-----|-----|---------|
| Parameter                      | Conditions                 | Min  | Typ | Max | Units   |
| Operating Voltage              |                            | -    | 5   | -   | V       |
| Linearity                      |                            | ±1.5 |     |     | %       |
| Terminal Resistance X          | X film side                | 200  | 300 | 550 | Ohm     |
| Terminal Resistance Y          | Y film side                | 300  | 600 | 900 | Ohm     |
| Operating Temperature          |                            | -10  | -   | 60  | °C      |
| Storage Temperature            |                            | -20  | -   | 70  | °C      |
| Transmittance                  |                            | 80   | -   | -   | %       |
| Life Time – Tapping Durability |                            | 1    | -   | -   | Million |
| Life Time – Pen Durability     | Stylus Pen or Finger Press | 1    | -   | -   | Million |
| Response Time                  |                            |      |     | 10  | ms      |

- **ITO Film:** Single Layer/Clear Hard Coating
- **Tail Type:** FPC by Golden Plated
- **Connection:** FPC Connector
- **RoHS Compliant**

## 5. Initialisation Codes

### 5.1. Command Definitions

|  <b>Command Definitions</b> |      |
|--|------|
| READ_DISPLAY_PIXEL_FORMAT  | 0x0C |
| SLEEP_OUT  | 0x11 |
| GAMMA_SET  | 0x26 |
| DISPLAY_OFF  | 0x28 |
| DISPLAY_ON   | 0x29 |
| SET_COLUMN_ADDRESS   | 0x2A |
| SET_PAGE_ADDRESS   | 0x2B |
| WRITE_MEMORY   | 0x2C |
| READ_MEMORY  | 0x2E |
| MEMORY_ACCESS_CONTROL  | 0x36 |
| WRITE_MEMORY_CONTINUE  | 0x3C |
| READ_MEMORY_CONTINUE   | 0x3E |
| PIXEL_FORMAT_SET   | 0x3A |
| FRAME_RATE_CONTROL   | 0xB1 |
| DISPLAY_FUNCTION_CONTROL   | 0xB6 |
| POWER_CONTROL_1  | 0xC0 |
| POWER_CONTROL_2  | 0xC1 |
| VCOM_CONTROL_1   | 0xC5 |
| VCOM_CONTROL_2   | 0xC7 |
| POWER_CONTROL_A  | 0xCB |
| POWER_CONTROL_B  | 0xCF |
| POSITIVE_GAMMA_CORRECTION  | 0xE0 |
| NEGATIVE_GAMMA_CORRECTION  | 0xE1 |
| DRIVER_TIMING_CONTROL_A  | 0xE8 |
| DRIVER_TIMING_CONTROL_B  | 0xEA |
| POWER_ON_SEQUENCE_CONTROL  | 0xED |
| UNDOCUMENTED_0xEF  | 0xEF |
| ENABLE_3G  | 0xF2 |
| INTERFACE_CONTROL  | 0xF6 |
| PUMP_RATIO_CONTROL   | 0xF7 |

## 5.2. Init Code

**Format:** (Command, Data1, Data2...DataN)

```
INTERFACE_CONTROL, 0x01, 0x01, 0x00,  
POWER_CONTROL_B, 0x00, 0xC1, 0x30,  
POWER_ON_SEQUENCE_CONTROL, 0x64, 0x03, 0x12, 0x81,  
DRIVER_TIMING_CONTROL_A, 0x85, 0x00, 0x7A,  
POWER_CONTROL_A, 0x39, 0x2C, 0x00, 0x34, 0x02,  
PUMP_RATIO_CONTROL, 0x20,  
DRIVER_TIMING_CONTROL_B, 0x00, 0x00,  
POWER_CONTROL_1, 0x26,  
POWER_CONTROL_2, 0x11,  
VCOM_CONTROL_1, 0x39, 0x37,  
VCOM_CONTROL_2, 0xA6,  
MEMORY_ACCESS_CONTROL, 0x08,  
DISPLAY_FUNCTION_CONTROL, 0x0A, 0xA2,  
FRAME_RATE_CONTROL, 0x00, 0x1B,  
ENABLE_3G, 0x00,  
GAMMA_SET, 0x01,  
PIXEL_FORMAT_SET, 0x55,  
POSITIVE_GAMMA_CORRECTION, 0x0f, 0x2D, 0x0E, 0x08, 0x12, 0x0A, 0x3D, 0x95, 0x31, 0x04, 0x10,  
0x09, 0x09, 0x0D, 0x00,  
NEGATIVE_GAMMA_CORRECTION, 0x00, 0x12, 0x17, 0x03, 0x0d, 0x05, 0x2c, 0x44, 0x41, 0x05, 0x0F,  
0x0a, 0x30, 0x32, 0x0F,  
WRITE_MEMORY,  
SLEEP_OUT, 0x0006,  
DelayMS(120),  
DISPLAY_ON
```

## 6. Quality Testing

Result Evaluation Criterion:

- T = 25 ± 2°C, Indoors, Not exposed to sunlight, Humidity = 60 ± 5 % RH.
- Operating State: Samples subject to the test shall be in operating conditions.

### 6.1. Reliability Test

| No. | ITEM                                  | CONDITION   | Pass/Fail  | REMARK   |
|-----|---------------------------------------|---|--|--|
| 1   | High Temperature Storage              | 80°C ± 2°C, 96Hrs   | Pass   | Module without confirmation                        |
| 2   | Low Temperature Storage               | -30°C ± 2°C, 96Hrs  | Pass   |  |
| 3   | High Temperature Operation            | 60°C, 96Hrs   | Pass   |  |
| 4   | Low Temperature Operation             | -10°C, 96Hrs  | Pass   |  |
| 5   | High Temperature & Humidity Storage   | 60 °C, 90%RH, 96Hrs   | Pass   |  |
| 6   | High Temperature & Humidity Operation | 40 °C, 90%RH, 96Hrs   | Pass   |  |
| 7   | Thermal Shock                         | -20°C->25°C->70°C->25°C<br>30min→30min→30min→30min<br>10 cycles         | Pass   |  |
| 8   | Vibration Test (Packaged)             | 10Hz~55Hz (1min)<br>Amplitude: 1.5mm<br>Each direction (x,Y,Z) for 2hrs | Pass   |  |
| 9   | Drop Test (Packaged)                  | Packing Weight (Kg)   | Drop Height (cm)                                       | Drop Direction 1 corner 3 edges 6 slides Each time |
|     |                                       | 0 ~ 45.4  | 122  |  |
|     |                                       | 45.4 ~ 90.8   | 76   |  |
|     |                                       | 90.8 ~ 454  | 61   |  |
|     |                                       | Over 454  | 46   |  |
| 10  | Electrostatic Test                    | Air Discharge<br>Apply 2KV with 5 times discharge for each polarity +/- | Contact Discharge<br>Apply 250V with 5 times discharge | Pass   |

| No. | ITEM | CONDITION  | Pass/Fail             | REMARK |
|-----|------|--|-----------------------|--------|
|     |      | 1. Temperature ambience: 15°C ~ 35°C<br>2. Relative Humidity: 30% ~ 60%<br>3. Energy storage capacitance: CS + CD: 150pF + 10%<br>4. Discharge Resistance (Rd): 330Ω + 10%<br>5. Discharge, Mode of operation: Single discharge (time between successive discharges at least 1s) (Tolerance if the output voltage indication: + 5%.) | for each polarity +/- |        |

## 7. Precautions for Using LCD Modules

### 7.1. Handling Precautions

- The display panel is made of glass and a polarizer. The glass is fragile. It tends to be chipped during handling, especially on the edges. Please avoid dropping or jarring. Please be careful not subject it to a mechanical shock by dropping it on impact.
- If the display panel is damaged and the liquid crystal substance leaks out, be sure not to get any of it in your mouth. If the substance contacts your skin or clothes, wash it off using soap and water.
- Do not apply excessive force to the display surface or the adjoining areas since this may cause the color tone to vary. Do not touch the display with bare hands. This will stain the display area and degrade insulation between terminals (some cosmetics are determined by the polarizer).
- The polarizer covering the display surface of the LCD module is soft and easily scratched. Handle this polarizer carefully. Do not touch, push or rub the exposed polarizer with anything harder than an HB pencil lead (e.g., glass, tweezers, etc.). Do not put or attach anything to the display area to avoid leaving marks on it. Condensation on the surface and contact with terminals due to cold temperatures will damage, stain or contaminate the polarizer. After products are tested at low temperatures they must be warmed up in a container before coming into contact with room-temperature air.
- If the display surface becomes contaminated, breathe on the surface and gently wipe it with a soft dry cloth. If it is heavily contaminated, moisten the cloth with one of the following solvents
  - Isopropyl alcohol
  - Ethyl alcohol Do not scrub hard as it might damage the display surface.
- Solvents other than those mentioned above may damage the polarizer. Especially the following.
  - Water
  - Ketone
  - Aromatic solvents Wipe off saliva or water drops immediately, contact with water over a long period may cause deformation or color fading. Avoid contact with oil and fat.
- Take necessary precautions to minimize corrosion of the electrode. Corrosion of the electrodes is accelerated by water droplets, moisture condensation or current flow in a high-humidity environment.
- Install the LCD Module by using the mounting holes. When mounting the LCD module, make sure it is free of twisting, warping and distortion. In particular, do not forcibly pull or bend the I/O cable or the backlight cable.
- Do not attempt to disassemble or process the LCD module.
- NC terminal should be open. Do not connect anything to it.
- If the logic circuit power is off, do not apply input signals.



- Control Electro-Static Discharge. Since this module uses a CMOS LSI, the same careful attention should be paid to electrostatic discharge as for an ordinary CMOS IC. To prevent the destruction of the elements by static electricity, ensure that an optimum work environment is maintained.
  - Before removing the LCM from its packing case or incorporating it into a set, be sure that the module and your body have the same electric potential. Be sure to ground your body when handling the LCD modules.
  - To reduce the amount of static electricity generated, do not conduct assembly and other work under dry conditions. To reduce the generation of static electricity, please ensure that the air in the work environment is not too dry. Relative humidity of 50%-60% is recommended. As much as possible, make the electric potential of your work clothes and that of the workbench the ground potential.
  - The LCD module is coated with a film to protect the display surface. Be careful when peeling off this protective film since static electricity may be generated.
- Since the LCM has been assembled and adjusted with a high degree of precision, avoid applying excessive shocks to the module or making any alterations or modifications to it.
  - Do not alter, modify or change the shape of the tab on the metal frame.
  - Do not make extra holes on the printed circuit board, modify its shape or change the positions of the components to be attached.
  - Do not damage or modify the pattern writing on the printed circuit board.
  - Do not modify the zebra rubber strip (conductive rubber) or heat seal connector.
  - Do not drop, bend or twist the LCM.

## 7.2. Storage Precautions

When storing the LCD modules, the following precautions are necessary.

- Store them in a sealed polyethylene bag. If properly sealed, there is no need for the desiccant.
- Store them in a dark place. Do not expose to sunlight or fluorescent light, keep the temperature between 0°C and 35°C, and keep the relative humidity between 40%RH and 60%RH.
- The polarizer surface should not come in contact with any other objects. (We advise you to store them in an anti-static electricity container in which they were shipped. Some Liquid crystals solidify under low temperatures (below the storage temperature range) leading to defective orientation or the generation of air bubbles (black or white). Air bubbles may also be generated if the module is subjected to low temperatures.
- If the LCD modules have been operating for a long time showing the same display patterns, the display patterns may remain on the screen as ghost images and a slight contrast irregularity may also appear. A normal operating status can be regained by suspending use for some time. It should be noted that this phenomenon does not adversely affect performance reliability.
- To minimize the performance degradation of the LCD modules resulting from the destruction caused by static electricity etc., please avoid holding the following sections when handling the modules'
  - The exposed area of the printed circuit board
  - Terminal electrode sections

## 8. Using LCD Modules

### 8.1. Installing LCD Modules

The hole in the printed circuit board is used to fix LCM as shown in the picture below. Attend to the following items when installing the LCM.

1. Cover the surface with a transparent protective plate to protect the polarizer and LC cell.

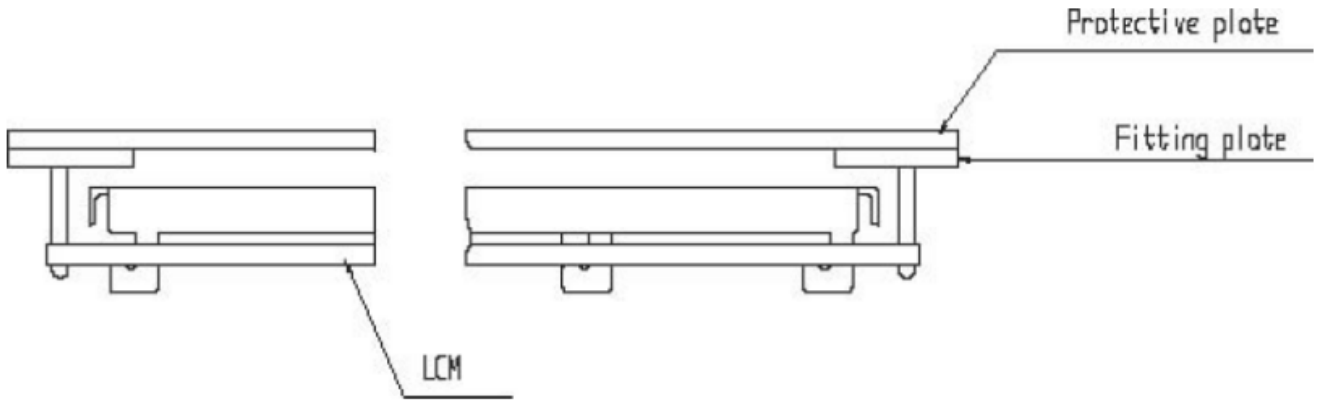

2. When assembling the LCM into other equipment, the spacer to the bit between the LCM and the fitting plate should have enough height to avoid causing stress to the module surface, refer to the individual specifications for measurements. The measurement tolerance should be  $\pm 0.1\text{mm}$ . Precaution for assembling the module with BTB connector:

Please note the position of the male and female connector position, don't assemble or assemble like the method that the following picture shows.

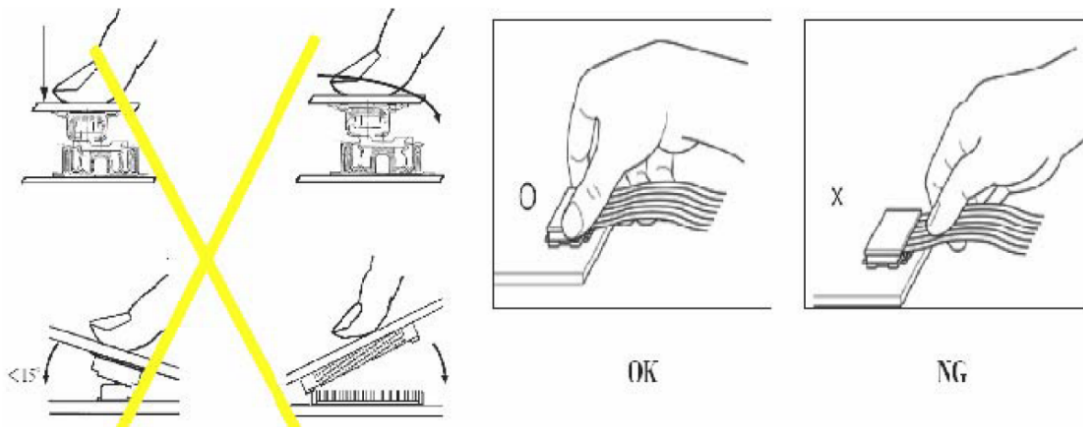

## 8.2. Precautions for Operation

1. The viewing angle varies with the change in liquid crystal driving voltage (VLCD). Adjust VLCD to show the best contrast.
2. It is an indispensable condition to drive LCDs within the specified voltage limit since a higher voltage than the limit causes a shorter LCD life. An electrochemical reaction due to direct current causes LCD's undesirable deterioration so the use of a direct current drive should be avoided.
3. Response time will be extremely delayed at a lower temperature than the operating temperature range and on the other hand at higher temperatures it shows dark color in them. However, those phenomena do not mean malfunction or out-of-order with LCDs, which will come back at the specified operating temperature.
4. If the display area is pushed hard during operation, the display will become abnormal. However, it will return to normal if it is turned off and then back on.
5. Slight dew depositing on terminals is a cause for electrochemical reaction resulting in terminal open circuit. Usage under the maximum operating temperature, 50%RH or less is required.
6. Input each signal after the positive/negative voltage becomes stable.
7. Please keep the temperature within the specified range for use and storage. Polarization degradation, bubble generation or polarizer peel-off may occur with high temperature and high humidity.

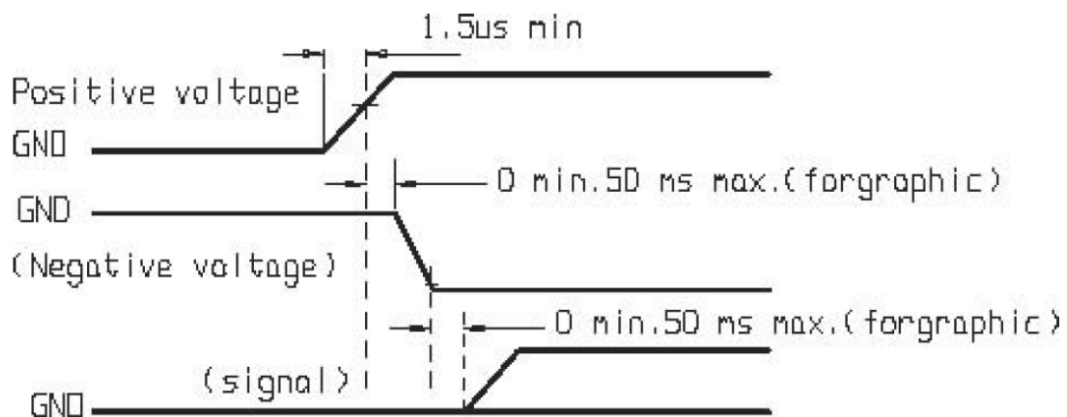

## 8.3. Safety

- It is recommended to crush damaged or unnecessary LCDs into pieces and wash them off with solvents such as acetone and ethanol, which should later be burned.
- If any liquid leaks out of a damaged glass cell and comes in contact with the hands, wash off thoroughly with soap and water. Limited Warranty.

## 8.4. Return LCM under Warranty

No warranty can be granted if the precautions stated above have been disregarded. The typical examples of violations are

- Broken LCD glass.
- PCB eyelet is damaged or modified.
- PCB conductors damaged.
- Circuit modified in any way, including the addition of components.
- PCB is tampered with by grinding, engraving or painting varnish.

Module repairs will be invoiced to the customer upon mutual agreement. Modules must be returned with a sufficient description of the failures or defects. Any connectors or cables installed by the customer must be removed completely without damaging the PCB eyelet, conductors and terminals.