

MODEL NO	"A" HEX NUT
5-0002-1	1/2 W/O SAFETY WIRE HOLES
5-0002-2	9/16 WITH SAFETY WIRE HOLES

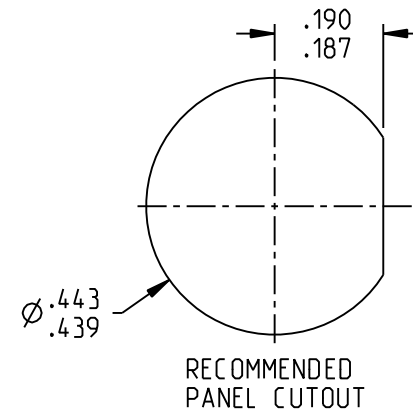
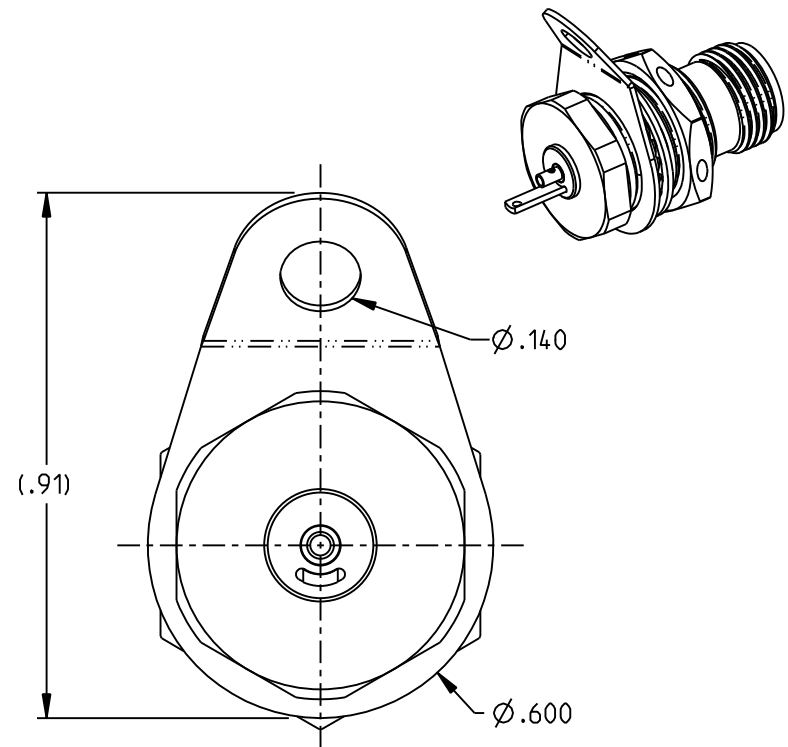
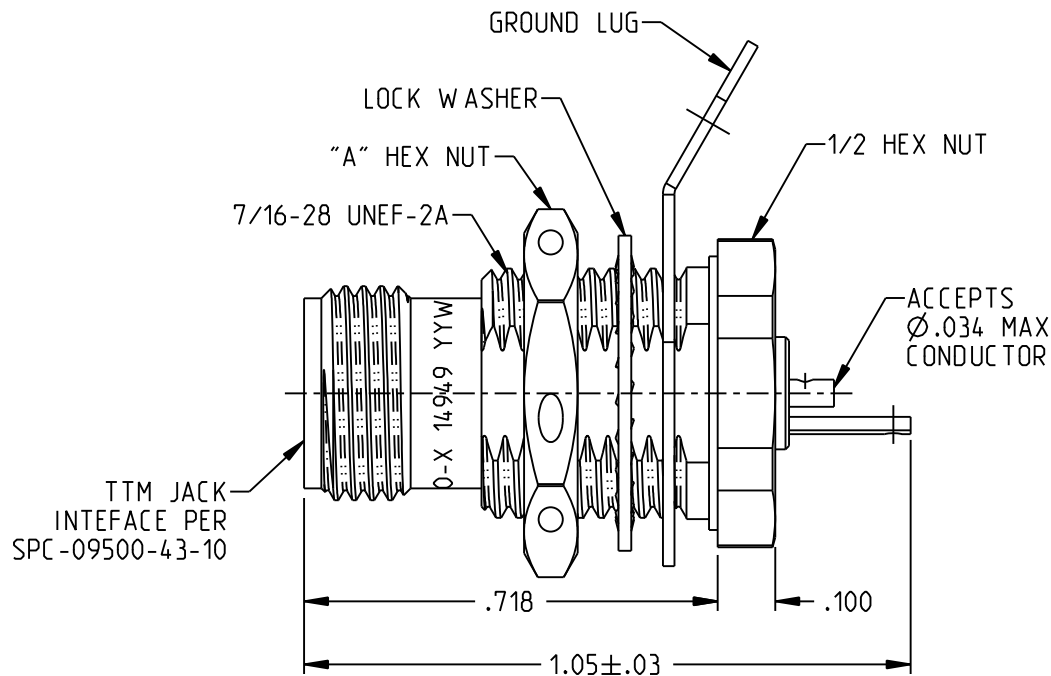

NOTES: UNLESS OTHERWISE SPECIFIED:

1. MATERIALS & FINISH:
 - 1.1 BODY: NICKEL PLATED BRASS
 - 1.2 OUTER INSULATOR & DIELECTRIC: PTFE (TEFLON)
 - 1.3 INTERMEDIATE CONTACT: GOLD PLATED BRASS
 - 1.4 CENTER CONTACT: GOLD PLATED BERYLLIUM COPPER
 - 1.5 GASKET: SILICONE RUBBER
 - 1.7 MOUNTING HARDWARE: NICKEL PLATED COPPER ALLOY

2. ELECTRICAL:
 - 2.1 IMPEDANCE: NON-CONSTANT
 - 2.2 FREQUENCY (MAX): 500 MHZ

3. TESTED PER TT-09 IAW TCS-150
4. PANEL NUT TORQUE (MAX): 35 IN-LBS
5. PANEL THICKNESS (MAX): .250

		TROMPETER	
	RoHS2 <input checked="" type="checkbox"/> 2015/863/EU	Title: TTM BULKHEAD, SOLDER POT JACK	
<small>NOTICE: The information in this drawing is PROPRIETARY and must not be used without the permission of Cinch Connectivity Solutions. It may contain data whose export is restricted. Verify status prior to exporting. INTERPRET DRAWING IN ACCORDANCE WITH ASME Y14.5-2018</small>	<small>UNLESS OTHERWISE SPECIFIED UNITS: INCH</small> .XX ±.02 .XXX ±.010 ANGLES ±2°	Model No. 5-0002-X	Date: 4/7/2022
Size A	DO NOT SCALE DRAWING	Sheet 1 OF 1	