

# DCN

## Super Capacitors



### FEATURES

Very fast charge/discharge – High power density – IEC 62391 compliant – Circuit board mountable

### APPLICATIONS

Battery backup/ alternative – Pulse power – Energy harvesting – LED Displays – Mechanical actuators – Audio systems

<b>Operating Temperature Range</b>		<b>-40°C to +60°C</b>	
<b>Storage Temperature</b>		<b>-40°C to +70°C</b>	
<b>Capacitance Tolerance @ 20°C</b>		+30%/-10% (Q tolerance), +20%/-20% (M tolerance) +10%/-10% (K tolerance), +50%/-20% (S tolerance)	
<b>Voltage</b>	<b>WVDC</b>	<b>2.7</b>	<b>5.5</b>
	<b>SVDC</b>	<b>2.8</b>	<b>5.7</b>
<b>Maximum Current</b>	<b>See standard part listing</b>		1 second discharge to ½ WVDC
<b>Operating Current</b>	<b>See standard part listing</b>		5 second discharge to ½ WVDC
<b>Leakage Current</b>	<b>See standard part listing</b>		72 hours, 25°C
<b>Life Time</b>	<b>1000 hours with rated voltage applied at 60°C</b>		
	<b>Capacitance change</b>	±30% of initially measured values	
	<b>ESR</b>	≤200% of initially specified values	
	<b>Leakage current</b>	≤ specified maximum value	
<b>Shelf Life</b>	<b>1000 hours with no voltage applied at 60°C</b>		
	<b>Capacitance change</b>	±30% of initially measured values	
	<b>ESR</b>	≤200% of initially specified values	
<b>Life Cycles</b> (25°C) 1 cycle= Charge to WVDC for 20s, constant voltage charging for 10s, discharge to ½ WVDC for 20s, rest for 10 s	<b>500,000 cycles</b>		
	<b>Capacitance change</b>	±30% of initially measured values	
	<b>ESR change</b>	≤200% of initially specified values	

Americas / EU  
Phone: 1-508-996-8561  
Email: cdena@cde.com



Asia  
Phone: 852-2793-0931  
Email: cdeasia@cde.com

# DCN

## Super Capacitors



### D < 18mm

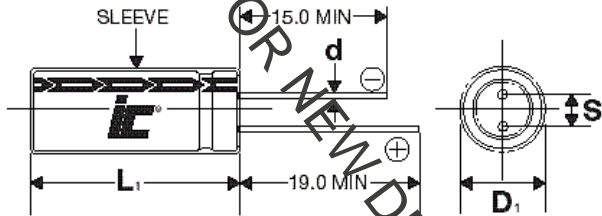

Lead spacing VS. Case diameter						
D	4	8(L<20)	8(L>20)	10	16	18
S	1.5	3.5	3.5	5.0	7.5	7.5
d	0.45	0.5	0.6	0.6	0.8	0.8

$L_1 = L (< 20\text{mm} + 1.5\text{mm}) (\geq 20\text{mm} + 2.0\text{mm})$   
 $D_1 = D (< 20\text{mm} + 0.5\text{mm}) (\geq 20\text{mm} + 1.0\text{mm})$   
 $S_1 = S \pm 0.5\text{mm}$

### Snap in type

### D ≥ 20mm

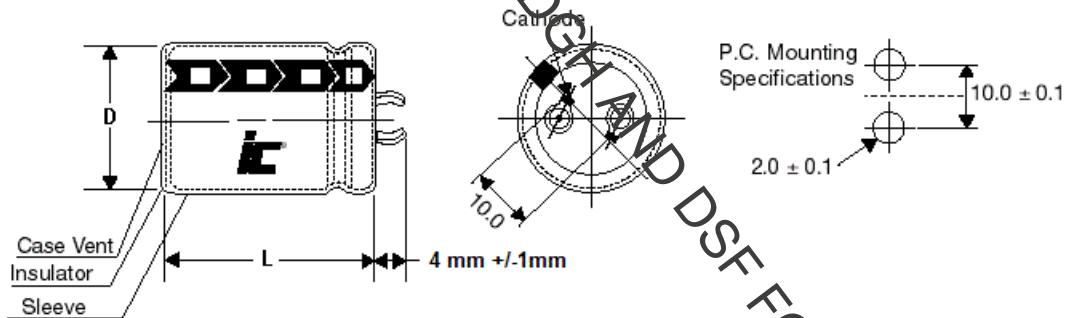

### 5.5 Volt units

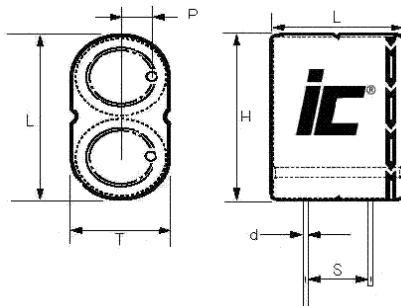

Capacitance (F)	Dims (LxHxT) (mm) +1.0mm	Lead spacing S (mm) +/-0.5mm	Lead diameter d (mm)	P (mm)
1	17.5x19.5x9	11.8	0.6	1.75
1.5	17.5x23.5x9	8.3	0.6	1.75
2	21.5x23.5x11	15.3	0.6	2.5
2.5	21.5x23.5x11	15.3	0.6	2.5