

REVISIONS					
P	LTR	DESCRIPTION	DATE	DN	APVD
B4		REVISED PER ECN-21-122181	26OCT2021	RZ	WK

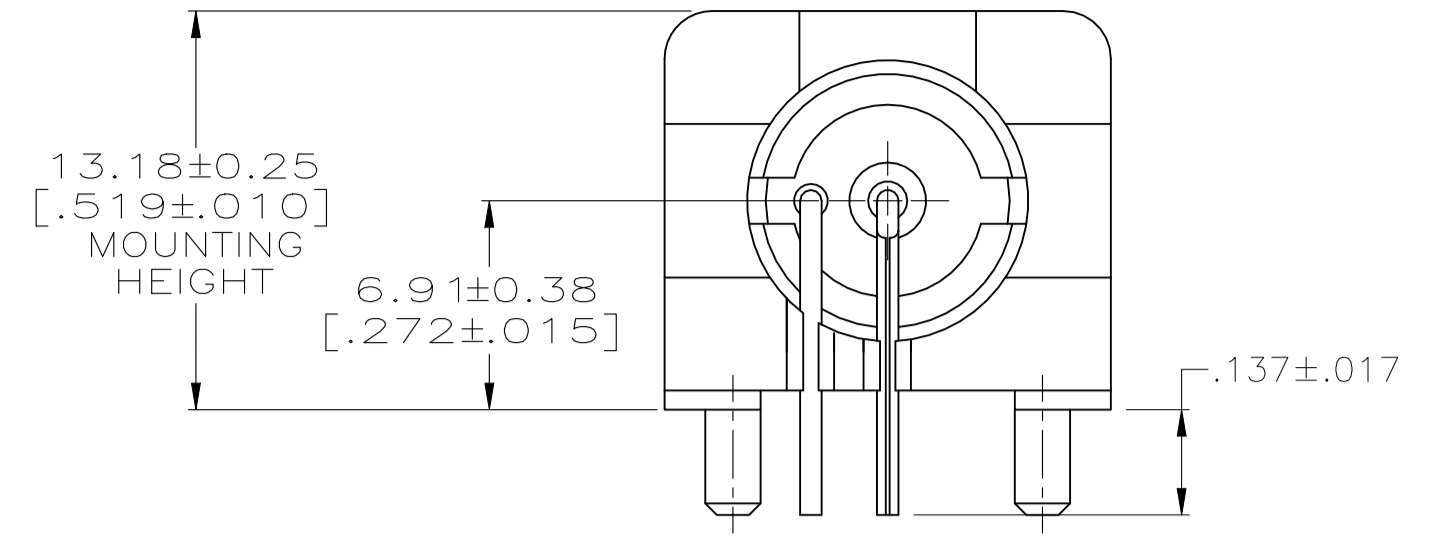

VIEW D
(SAME AS VIEW A
EXCEPT AS SHOWN)

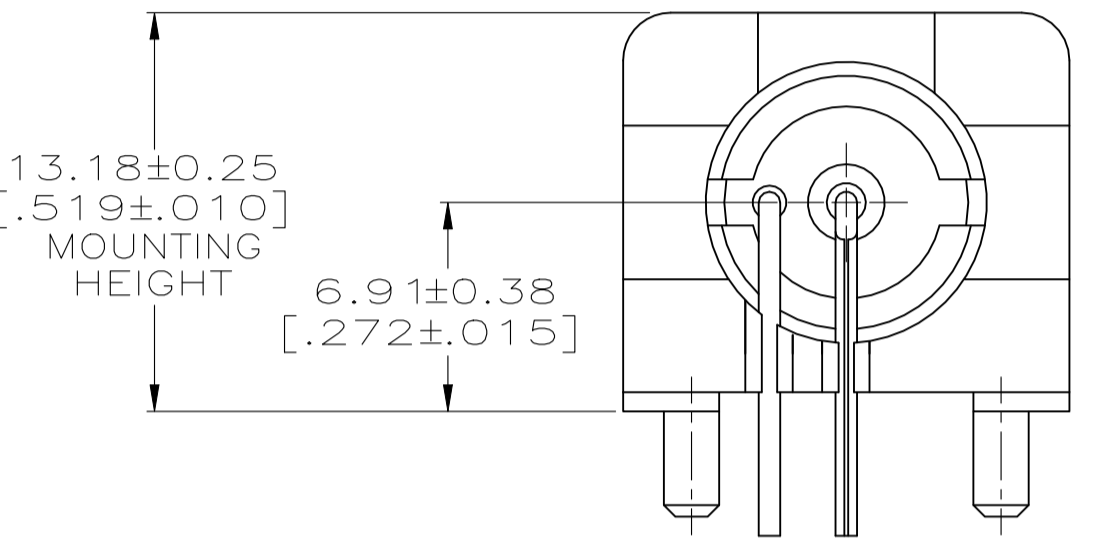

VIEW C
(SAME AS VIEW A
EXCEPT AS SHOWN)

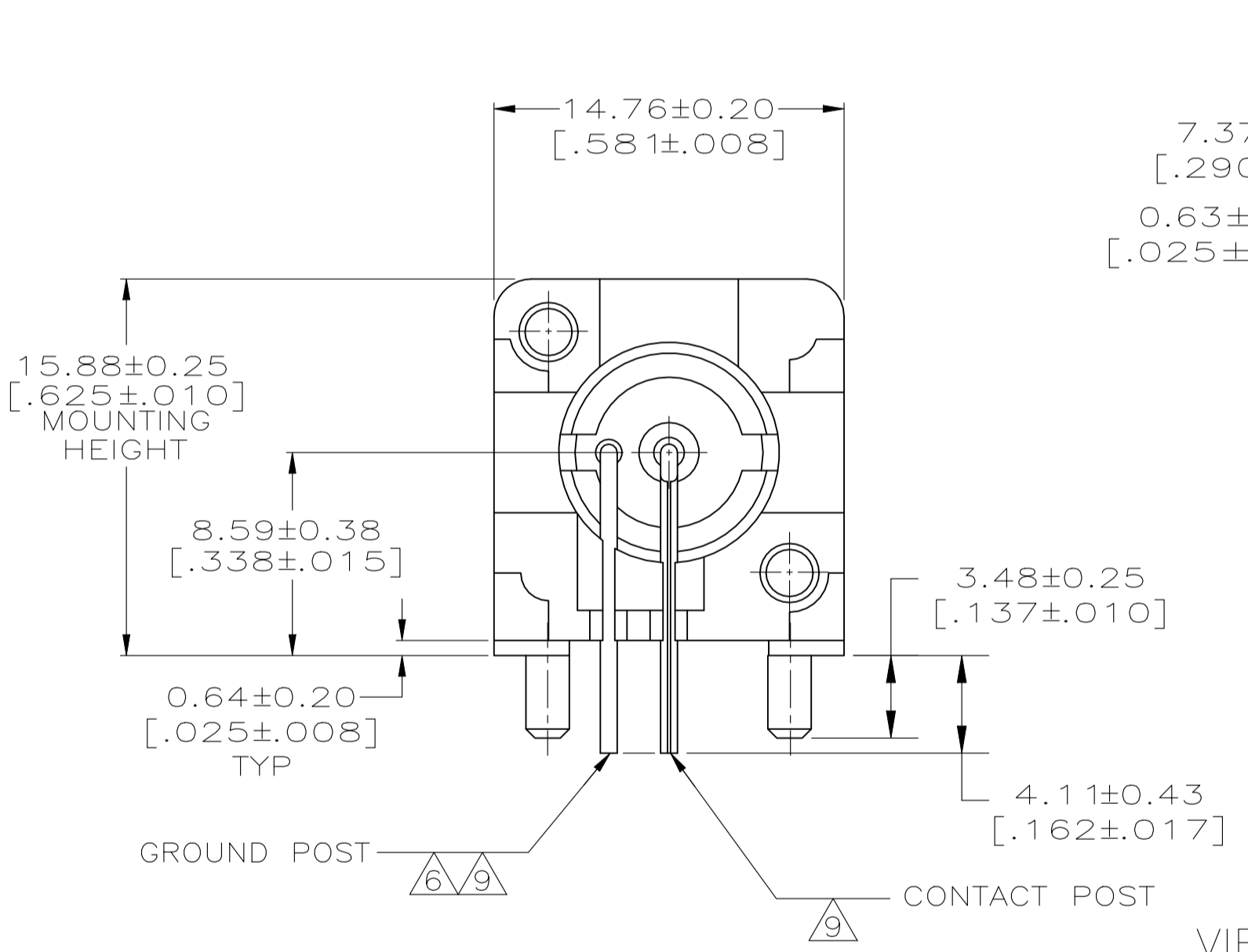

VIEW A

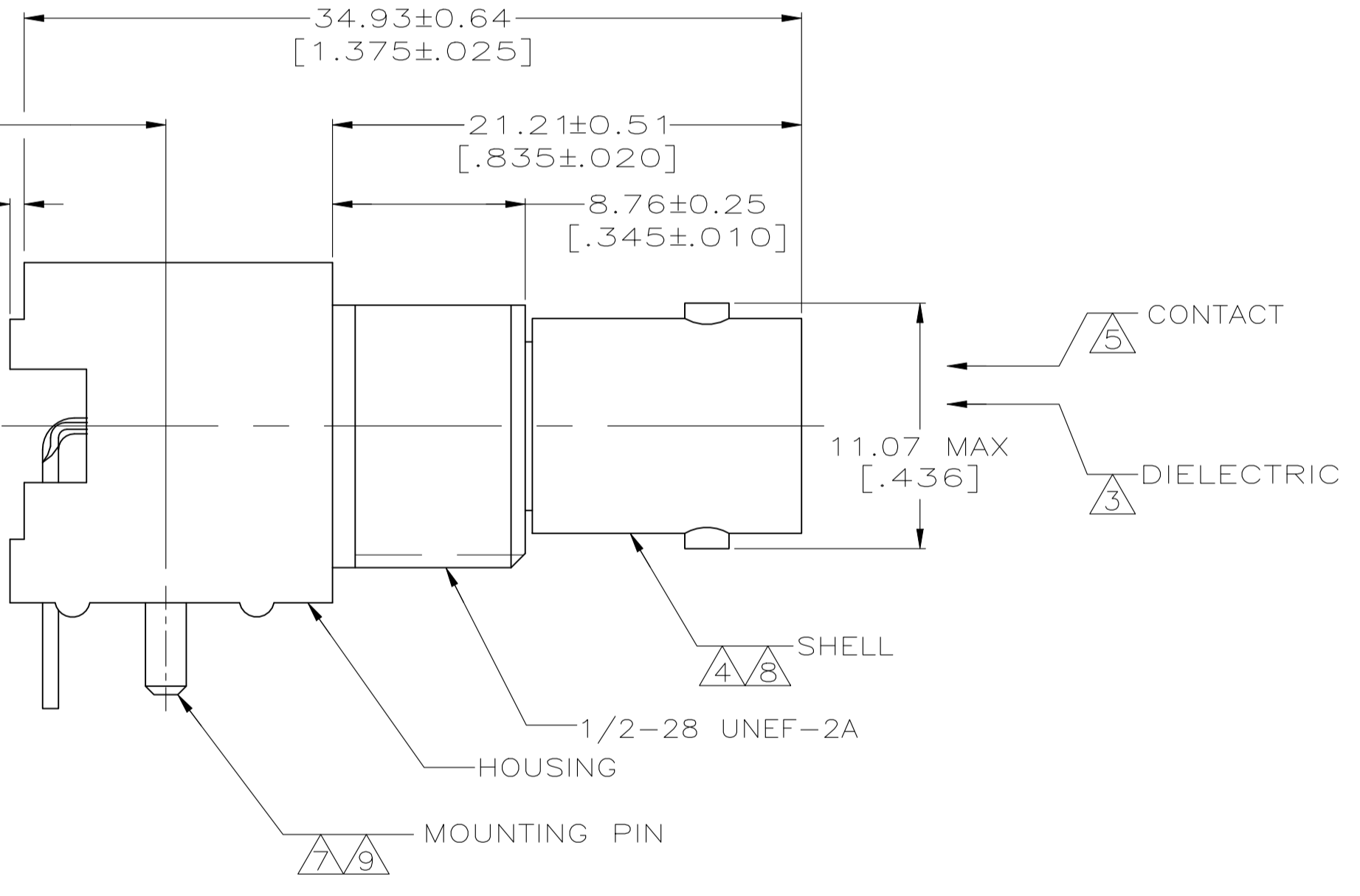
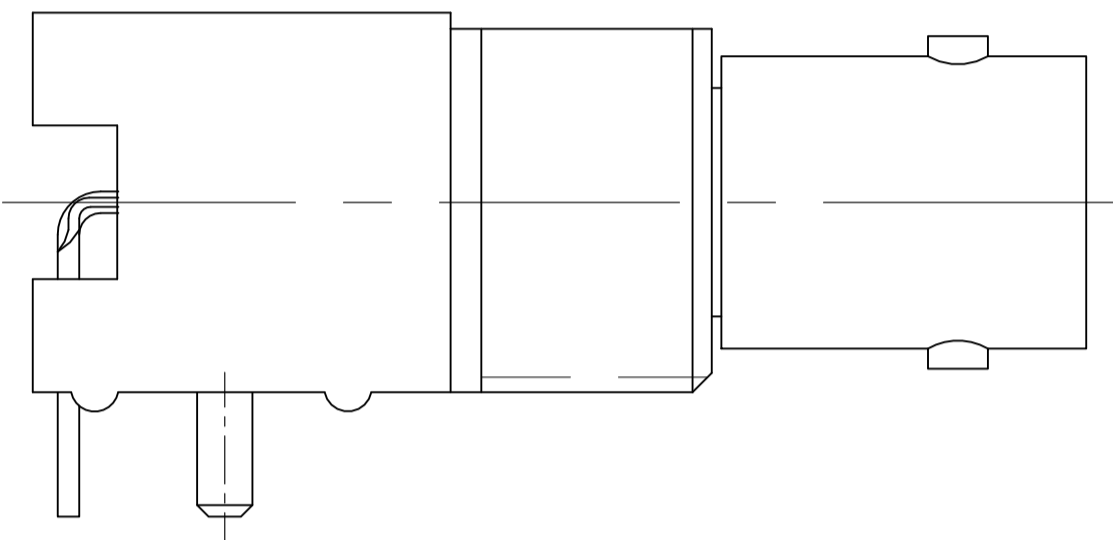
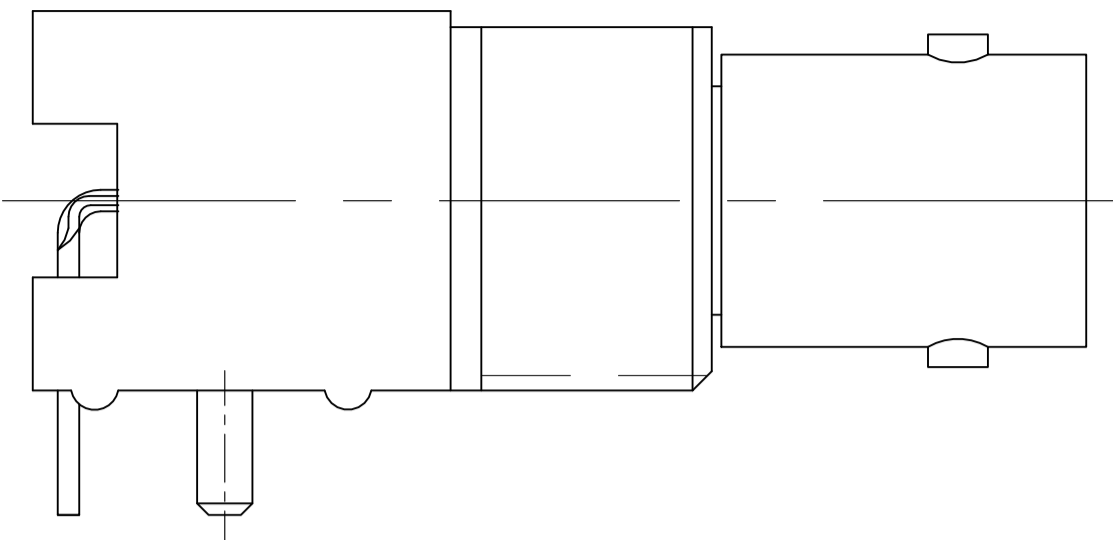

- 1 POLYESTER PBT PER MIL-M-24519, TYPE GPT-15F, UL94V-O RATED, COLOR:WHITE
- 2 POLYESTER PBT PER MIL-M-24519, TYPE GPT-15F, UL94V-O RATED, COLOR:BLACK
- 3 POLYMETHYLPENTENE, GENERAL PURPOSE.
- 4 ZINC PER QQ-Z-363.
- 5 PHOSPHOR BRONZE PER QQ-B-750.
- 6 BRASS PER ASTM-B-453.
- 7 BRASS PER ASTM-B-16.
- 8 NICKEL PLATE PER QQ-N-290, 3.81 μm [.000150] MINIMUM THICK.
- 9 TIN PLATE PER ASTM-B-545, 3.81 μm [.000150] MINIMUM THICK.
- 10 GOLD PLATE PER MIL-G-45204, 0.76 μm [.000030] MINIMUM THICK.
- 11 GOLD PLATE PER MIL-G-45204, 1.27 μm [.000050] MINIMUM THICK.
- 12. SEE INSTRUCTION SHEET 408-2769.
- 13. RECOMMENDED TORQUE FOR NUT(part 2) : 0.9 Nm.

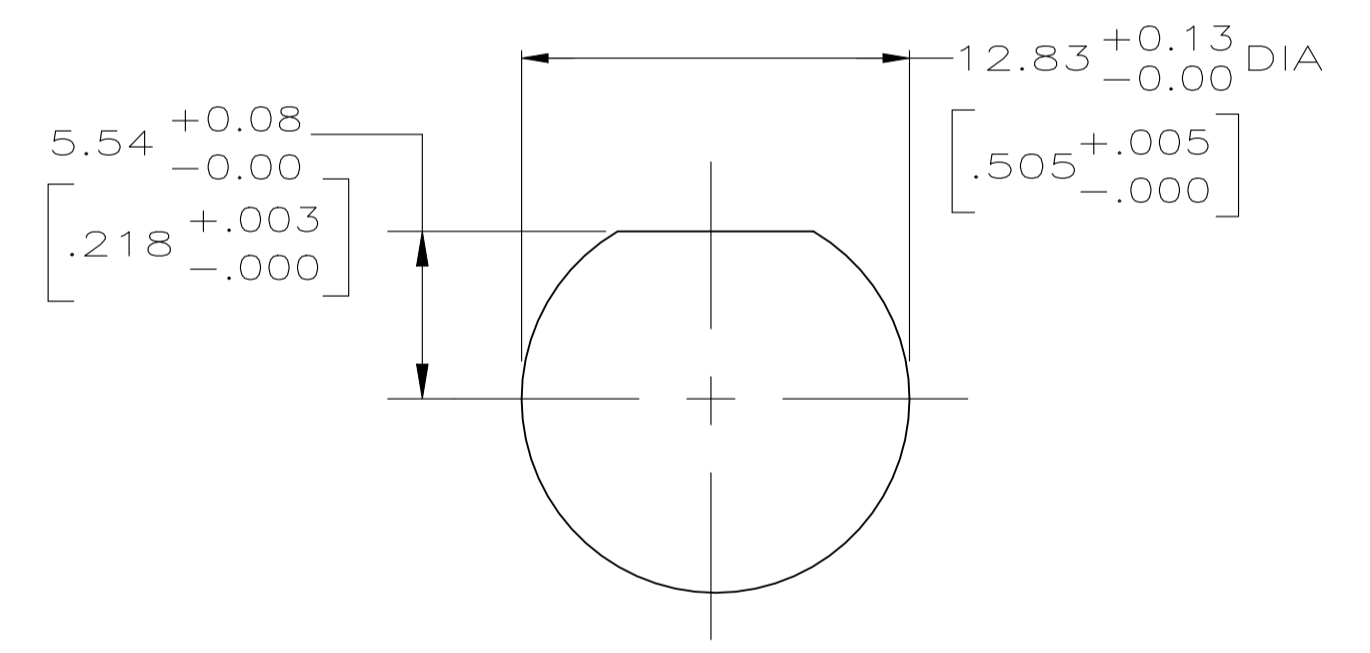

RECOMMENDED PANEL CUTOUT

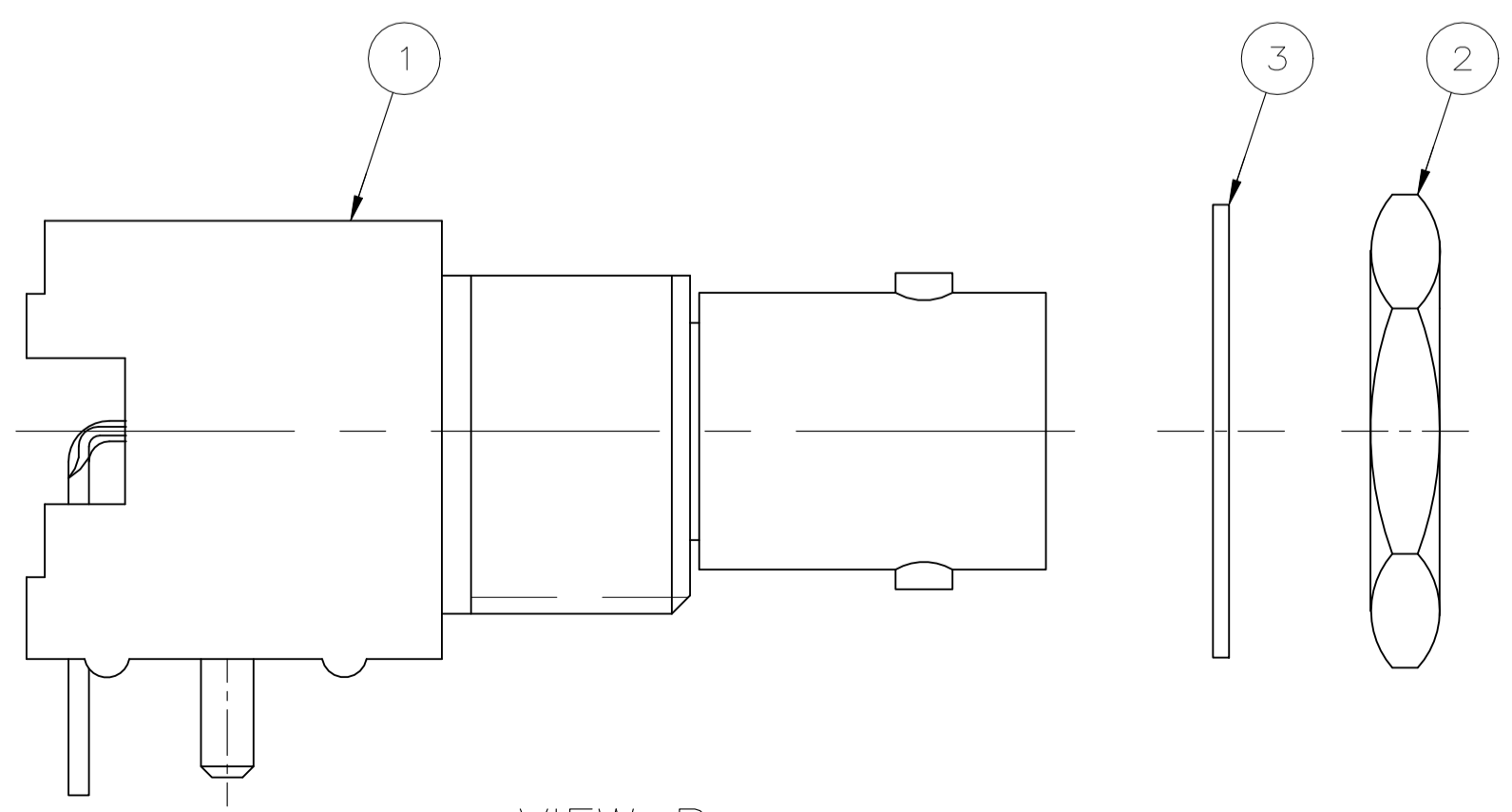

VIEW B

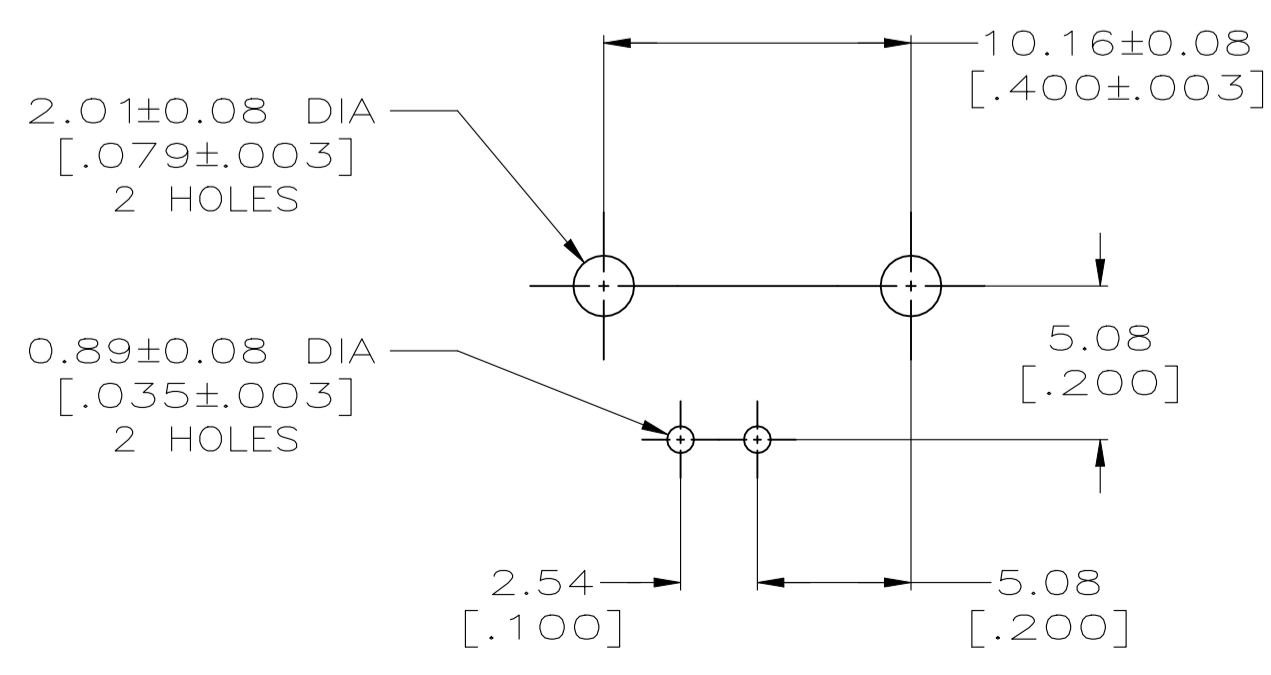

PCB CONFIGURATION

CONTACT FINISH	HOUSING MATERIAL	VIEW	LOCKWASHER	JAM NUT QTY=1	ASSEMBLY QTY=1	PART NUMBER
10	2	D	-	-	-	1-5227161-8
-	-	B	1-329632-2	1-329631-2	5227161-9	1-5227161-7
-	-	B	1-329632-2	1-329631-2	5227161-6	1-5227161-6
10	2	C	-	-	-	1-5227161-5
10	2	C	-	-	-	5227161-9
10	2	C	-	-	-	5227161-7
10	2	A	-	-	-	5227161-6
10	2	A	-	-	-	5227161-3
9	2	A	-	-	-	5227161-2
9	2	A	-	-	-	5227161-1

THIS DRAWING IS A CONTROLLED DOCUMENT.

DIMENSIONS: INCHES	TOLERANCES UNLESS OTHERWISE SPECIFIED:	DIN L. VARELA - DOCKS	TE Connectivity
0. PLC ± -	1. PLC ± -	J. HAVENER	
2. PLC ± 0.05 [.002]	3. PLC ± -	S. BURKHOLDER	
4. PLC ± -	ANGLES ± -		
MATERIAL	FINISH	APVD	RESTRICTED TO
		NAME	
		PRODUCT SPEC	
		APPLICATION SPEC	
		SIZE	
		CAGE CODE	
		DRAWING NO	
		WEIGHT	
		0.000000	
		A1 00779	
		C=5227161	
		CUSTOMER DRAWING	
		SCALE	
		4:1	
		SHEET	
		1 of 1	
		REV	
		B4	