

527-019

**EMI/RFI D-Subminiature Split Backshell**  
for Individual and Overall Shielding with Strain Relief



MIL-DTL-24308  
D-Subminiature

527-019 M 02 03 R5 F 1 F

- Basic Part No. \_\_\_\_\_
  - Finish Symbol (Page 3) \_\_\_\_\_
  - Shell Size \_\_\_\_\_
  - Dash No. (Table V) \_\_\_\_\_
  - Receptacle Mounting \_\_\_\_\_
    - F0 = Front Mounting
    - R1-R5 = Rear Mounting
    - CC = Cable to Cable
- F = Strain Relief, G = Gland Nut
  - 0 = Without EMI Gasket
  - 1 = With EMI Gasket
  - Jackscrew Type (page A-4)
  - Omit if not cable-to-cable
  - M = Turnable Males

1. Metric dimensions (mm) are indicated in parentheses.
2. **DO NOT USE CONNECTORS WITH FLOAT MOUNTINGS.**
3. For front mount, mating connector must be mounted to panel using M24308/26 female screwlocks. For rear mount, use Glennair GK134.
4. Individual and overall shield. Thickness range: .031 (.8) to .188 (4.8).

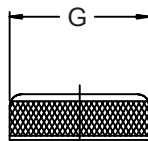

Style G Gland Nut

#4-40 UNC (2 Places)

RFI/EMI Gasket (Optional)

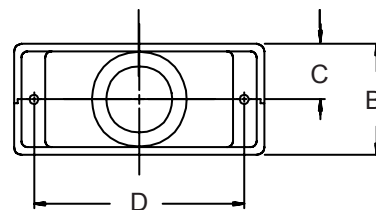
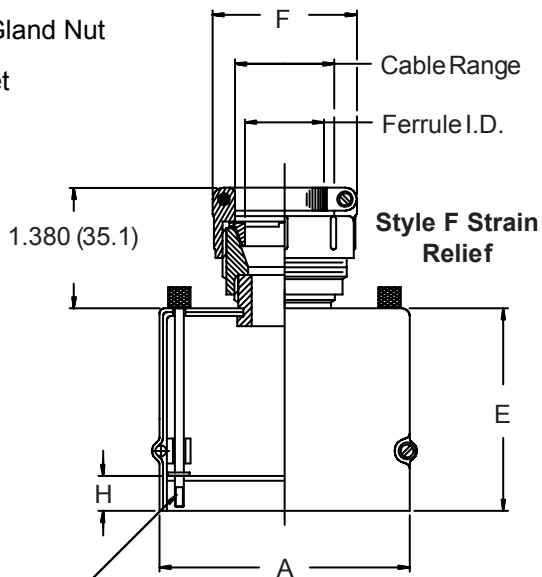

**TABLE I: CONNECTOR/SHELL INTERFACE DIMENSIONS**

Shell Size	Com'l Shell Size Ref	A Max	B Max	C	D ±.005 (.1)
01	E/09	1.393 (35.4)	.624 (15.8)	.312 (7.9)	.984 (25.0)
02	A/15	1.706 (43.3)	.624 (15.8)	.312 (7.9)	1.312 (33.3)
03	B/25	2.265 (57.5)	.624 (15.8)	.312 (7.9)	1.852 (47.0)
04	C/37	2.900 (73.7)	.624 (15.8)	.312 (7.9)	2.500 (63.5)
05	D/50	2.800 (71.1)	.750 (19.1)	.375 (9.5)	2.406 (61.1)

**TABLE II: FRONT MOUNTED RECEPTACLE BACKSHELL DIMENSIONS**

Shell Size	Com'l Shell Size Ref	E Dim	H
01	E/09	1.750 (44.5)	.340 (8.6)
02	A/15	1.750 (44.5)	.340 (8.6)
03	B/25	2.000 (50.8)	.343 (8.7)
04	C/37	2.000 (50.8)	.343 (8.7)
05	D/50	2.000 (50.8)	.343 (8.7)

**TABLE III: REAR MOUNTED RECEPTACLES BACKSHELL DIMENSIONS**

Dash No.	Panel Thickness	H	E Dim	
			Sizes 01 & 02	Sizes 03 - 05
R1	.031 (.8)	.247 (6.3)	1.656 (42.1)	1.904 (48.4)
R2	.062 (1.6)	.216 (5.5)	1.625 (41.3)	1.873 (47.6)
R3	.093 (2.4)	.185 (4.7)	1.594 (40.5)	1.842 (46.8)
R4	.125 (3.2)	.154 (3.9)	1.563 (39.7)	1.811 (46.0)
R5	.047 (1.2)	.231 (5.9)	1.640 (41.7)	1.888 (48.0)

**TABLE IV: CABLE TO CABLE DIMENSIONS**

Shell Size	E Dim	H ±.015 (.4)
01	1.580 (40.1)	.185 (4.7)
02	1.580 (40.1)	.185 (4.7)
03	1.830 (46.5)	.187 (4.7)
04	1.830 (46.5)	.187 (4.7)
05	1.830 (46.5)	.187 (4.7)

**TABLE V: CABLE ENTRY**

Dash No.	F ± .031 (0.79) Max	G ± .031 (0.79) Max	Ferrule I.D.	Cable Range	
				Min	Max
02	.968 (24.6)	.781 (19.8)	.125 (3.2)	.125 (3.2)	.250 (6.4)
03	1.062 (27.0)	.906 (23.0)	.250 (6.4)	.250 (6.4)	.375 (9.5)
04	1.156 (29.4)	1.031 (26.2)	.375 (9.5)	.312 (7.9)	.500 (12.7)
05	1.218 (30.9)	1.156 (29.4)	.500 (12.7)	.437 (11.1)	.625 (15.9)
06	1.343 (34.1)	1.281 (32.5)	.625 (15.9)	.562 (14.3)	.750 (19.1)