

527-142 Solid TAG Ring® EMI/RFI Backshell for Cannon DPX4 Series Connectors

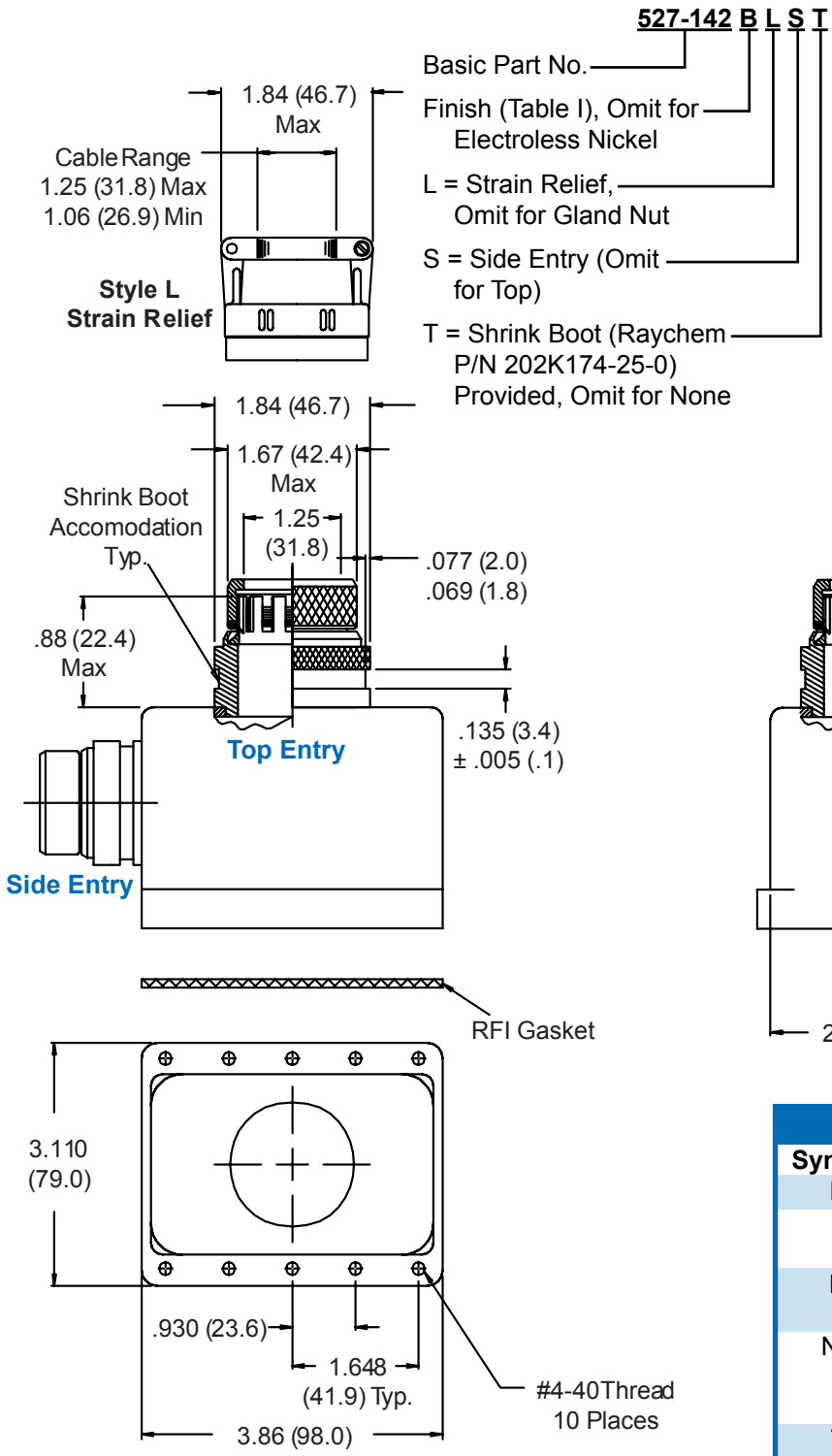

1. Metric dimensions (mm) are indicated in parentheses.
2. Material/Finish:
Backshell, Tag Ring Body and Clamp = Al Alloy/Finish per Part Number Development
TAG Ring® Nut = Al Alloy/Gold Iridite
TAG Ring® Spring = Beryllium Copper/Gold Plate
Hardware = SST/Passivate
RFI Gasket = Monel and Silicone

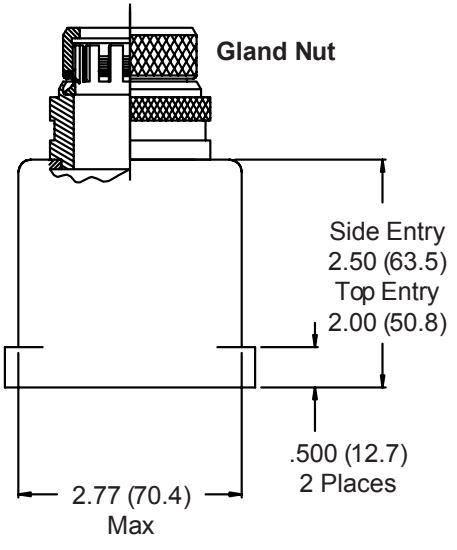

TABLE I - FINISH OPTIONS	
Symbol	Finish
B	Cadmium Plate, Olive Drab
J	Iridite, Gold Over Cadmium Plate over Nickel
N	Cadmium Plate, Olive Drab, Over Nickel
NF	Cadmium Plate, Olive Drab, Over Electroless Nickel (1000 Hour Salt Spray)
T	Cadmium Plate, Bright Dip Over Nickel (500 Hour Salt Spray)

**CONSULT FACTORY FOR
OTHER AVAILABLE FINISHES**