

REVISIONS			
REV.	DESCRIPTION	DATE	APPROVED
A	INITIAL RELEASE	09/30/11	D.N.

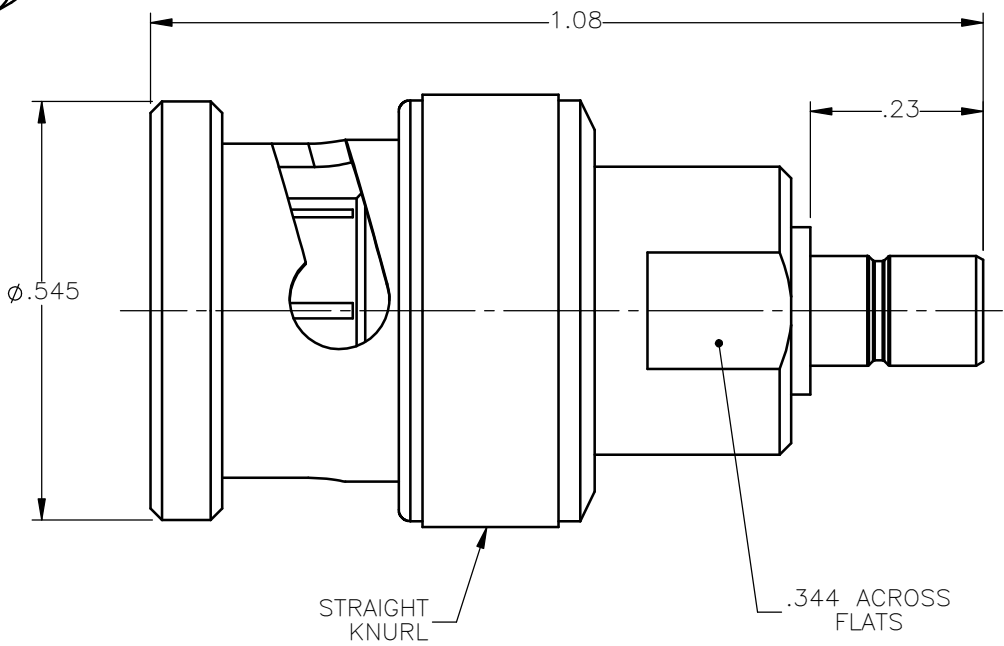

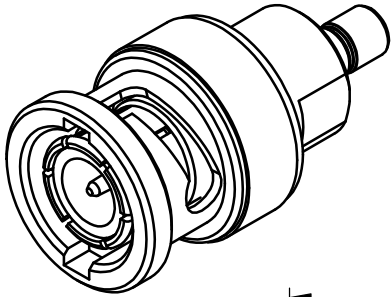

NOTES:

MATERIALS:

1. INSULATORS = VIRGIN WHITE TEFLON PER ASTM D1710, GRADE 1, TYPE I, CLASS "B".
2. SPRING WASHERS = BERYLLIUM COPPER PER ASTM B196, ALLOY C17300, TEMPER TD04.
3. GASKET = SILICONE RUBBER PER MIL-R-5847.
4. ALL OTHER METAL PARTS = BRASS PER ASTM B16, ALLOY C36000, TEMPER H02.

FINISHES:

1. CONTACTS = GOLD PLATE PER MIL-G-45204, TYPE II, CLASS 1, GRADE C, OVER .00010 TO .00020 STRESS FREE SULFAMATE NICKEL PER QQ-N-290.
2. ALL OTHER METAL PARTS = GOLD PLATE PER MIL-G-45204, TYPE II, CLASS 0, GRADE C, OVER .00010 TO .00020 COPPER STRIKE PER MIL-C-14550.

UNLESS OTHERWISE SPECIFIED DIMENSIONS ARE IN INCHES TOLERANCES ON	DWN:	DATE	 <b>Property of Radiall</b> This document cannot be reproduced or communicated to a third party without prior written permission of RADIALL.			
	D.N.	09/30/11				
DECIMAL	ANGLE	CHKD:	DATE	<b>BNC PLUG TO SMB MALE JACK ADAPTER</b>		
		J.S.	09/30/11			
		APVD:	DATE			
		J.M.	09/30/11			
REFERENCE:	MATERIALS & FINISHES:		SIZE	FSCM NO.	DWG NO.	REV
ORIGINATED: D.N. DATE: 09/31/11	SEE NOTES		A	19505	5404-1501-000	A
			SCALE 4:1	THIRD ANGLE PROJECTION		SHEET 1 OF 1

5404-1501-000