

WITHOUT CPA

SEALED ASSEMBLY VIEWS

FOR REFERENCE ONLY INSULATOR VIEWS

SCALE 2.000

SCALE 5X

POLARIZATION OPTIONS FULL SIZE SHOWN W/CPA

POLARIZATION OPTIONS FULL SIZE SHOWN W/O CPA

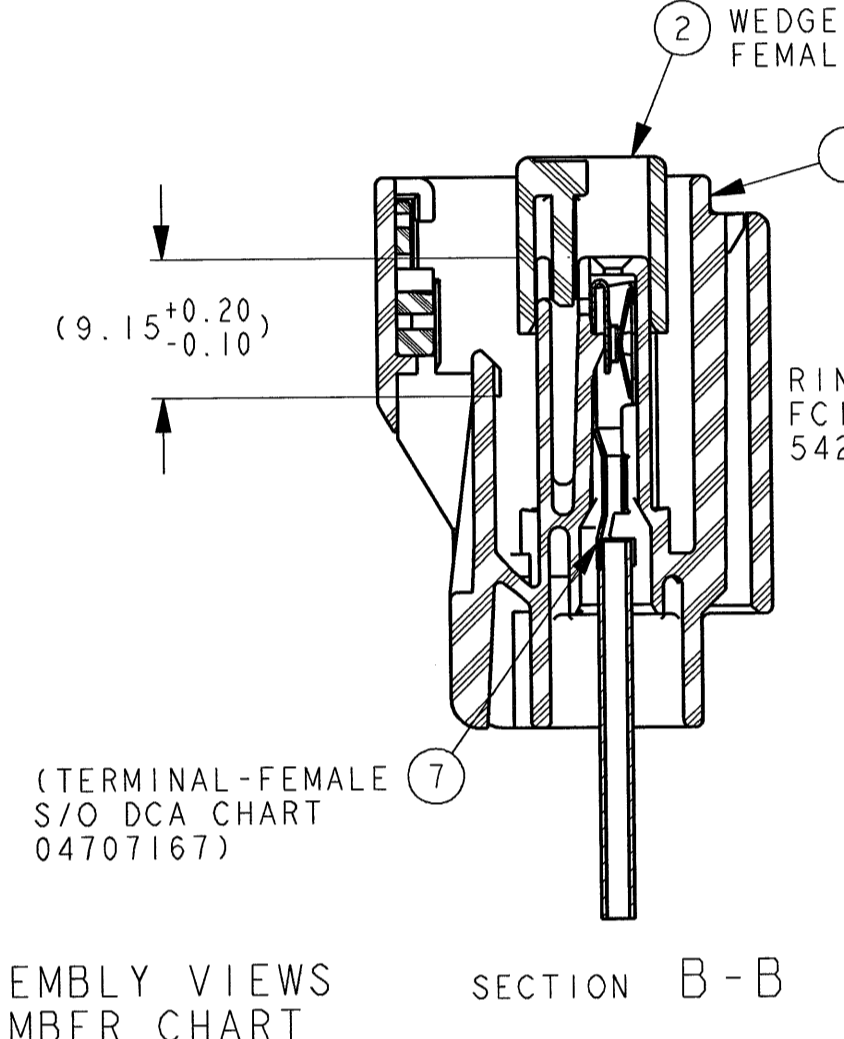
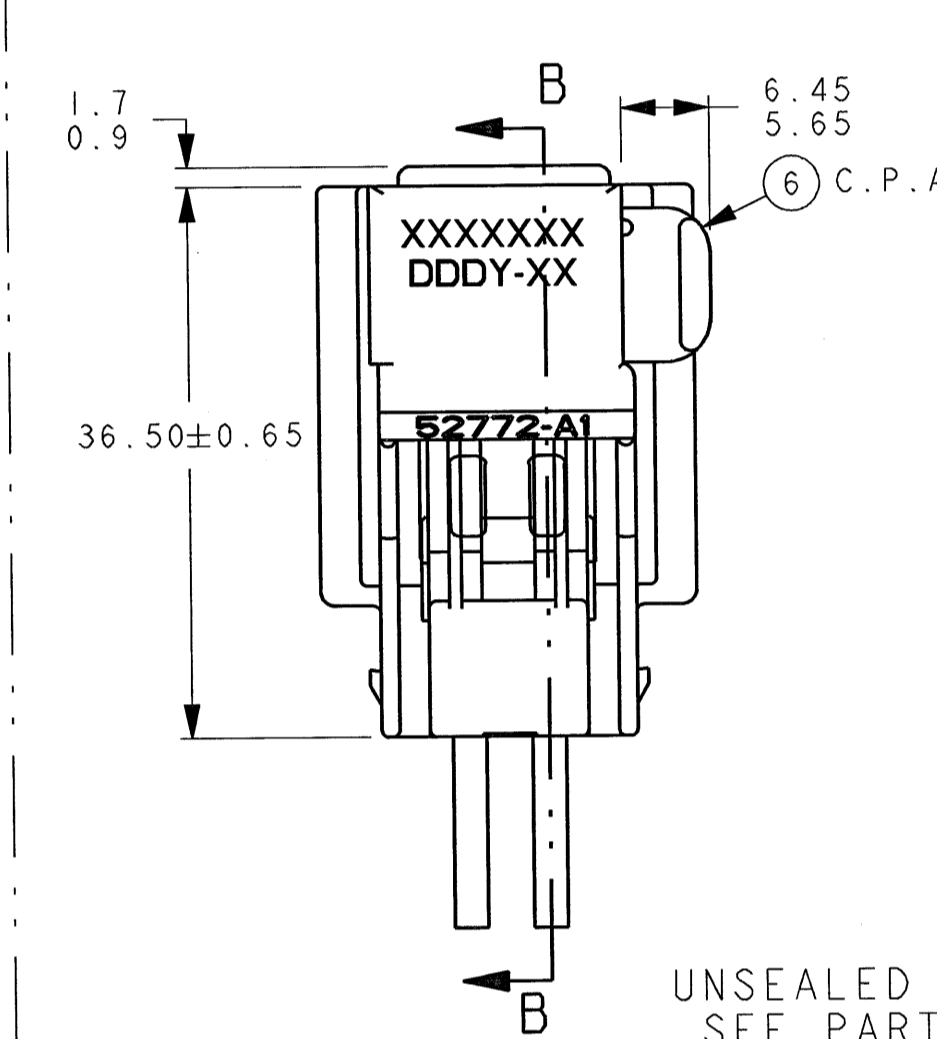
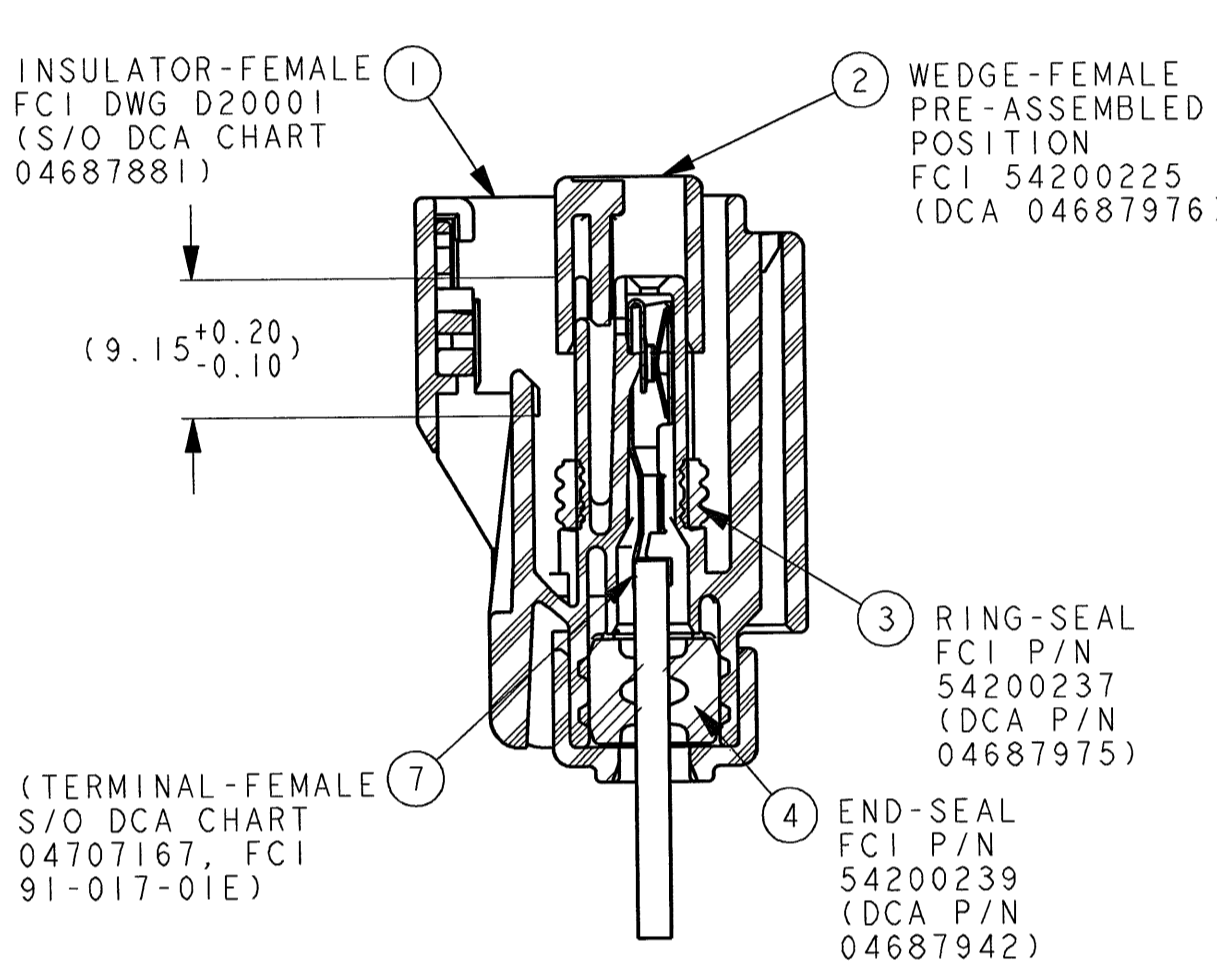
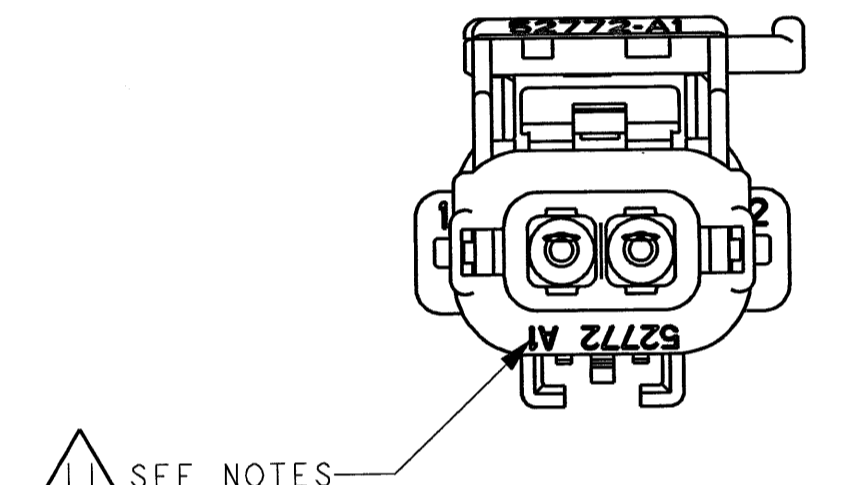

RING SEAL SHOWN AS REFERENCE FOR 54200263 ASSY ONLY

- NOTES: QUALITY ASSURANCE REQUIREMENTS PER DCA PS-7300... ENGINEERING APPROVAL OF SUPPLIER SAMPLES... CHANGES IN DESIGN COMPOSITION OR PROCESSING... WIRING FABRICATORS MUST PURCHASE FROM SOURCES SHOWN... ALL THE SEALED CONNECTOR APPLICATIONS MUST BE USED WITH DCA WIRE SPEC. MS-8288 OR MS-9502 THIN WALL X-LINK ONLY... A- ASSEMBLIES WITH FCI P/N 54200239 OR 54200240 END SEAL MUST BE USED WITH 20 THRU 14 GAGR WIRES (INS. Ø1.70 MIN - Ø2.7 MAX)... B- ASSEMBLIES WITH FCI P/N 54200241 END SEAL MUST BE USED WITH 12 OR 10 GAGE WIRES (INS. Ø3.07 MIN - Ø4.09 MAX)... FCI P/N'S 54200238 RING SEAL & 54200240 END SEAL BAKED AT 450°F FOR 5 HOURS... ALL NON-SEALED APPLICATIONS MAY BE USED WITH ANY WIRE INSULATION 22 GAGE THRU 10 GAGE (EXCEPT AS NOTED) PROVIDING THAT A TERMINAL GRIP FOR THAT CORE/INSULATION COMBINATION IS SHOWN ON THE FEMALE TERMINAL DRAWING... MAX. INSULATION CRIMP WIDTH = 4.50 MAX. INSULATION CRIMP HEIGHT = 4.50 MAX. INSULATION DIA = 4.09 (10 GA THIN WALL)... USE WITH CAVITY PLUG FCI P/N 54200005 (DCA P/N 56038308) WHEN REQ'D USE WITH DOUBLE X-MAS TREE CLIP DCA P/N 04707091 WHEN REQUIRED USE WITH SINGLE X-MAS TREE CLIP DCA P/N 04625797 WHEN REQUIRED... DIRECT CONNECT DRAWING NO. 04707027... TEST METHOD PER DCA PERFORMANCE SPEC# PF-9600. CONNECTOR ENGAGE & DISENGAGE WITH LATCH DEPRESSED FORCE NOT TO EXCEED 75 N.FOR THIS SYSTEM... CPA SEATING FORCES - 40 N. MAX WEDGE SEATING FORCES - 100 N. MAX X-MAS TREE CLIP INSERTION FORCES - 75 N. MAX... SUPPLIER, MOLD & CAVITY I.D.SIGNIFIES TOOL OWNERSHIP, FOR REFERENCE... ANNUAL QUALITY REQUIREMENTS: IT IS PERMISSIBLE TO PERFORM CONTINUOUS CONFORMANCE PER FCI SPECIFICATION #40A-001 INSTEAD OF ANNUAL LAYOUT & ANNUAL PV REQUIREMENTS OF QS-9000 SECTION 2 & PF-9600... ALL NON-REFERENCE DIMENSIONS ARE REQUIRED... - USE INDEX A, BLACK SEALED AND UNSEALED FOR ALL AFFECTED INSULATOR CAVITIES... - CURRENT PRODUCTION TOOLING... - POINT OF LAST RUN... SERVICE TOOLING GUIDE INFORMATION PER APEX TRAINING MANUAL... \*\* FCI P/N 54200259 NOT PRODUCED USE FCI P/N 55200200... MUST CONFORM TO THE FOLLOWING DCA/YNA STANDARDS: PF-9600 PERFORMANCE (DCA) EXCEPT AS NOTED ABOVE PS-7300 QUALITY ASSURANCE (DCA) PS-4480-CEK-4 (DCA) PART 1, D., (G-009-2 YNA) PS-9065 REGIRD (DCA), (G-009-3 YNA) PS-9227 DATA EXCHANGE (DCA), (G-009-7 YNA) PS-10052 INFORMATION SECURITY (DCA)... UNCONTROLLED FCI AUTOMOTIVE 12/7/2006 AMERICAS FCI MASTER COPY WHEN IN RED... THIS DRAWING, DESIGN AND ALL OTHER INFORMATION CONTAINED HEREIN IS PROPRIETARY AND THE PROPERTY OF FRAMATOME CONNECTORS INTERNATIONAL INC. AND MAY NOT BE COPIED, REPRODUCED OR DISCLOSED TO ANY THIRD PARTY WITHOUT THE EXPRESS WRITTEN PERMISSION OF FRAMATOME CONNECTORS INTERNATIONAL, INC. THIRD ANGLE PROJECTION... FRAMATOME CONNECTORS INTERNATIONAL, Inc. 1770 Marie Street Westland, Michigan 48185-3233... UNLESS OTHERWISE SPECIFIED... DIMENSIONS: 1 PLACE DIM ± 0.25 2 PLACE DIM ± 0.10 ANGULAR DIM ± 2°... DO NOT SCALE DRAWING... SCALE: 2X & NOTED... MATERIAL: NOTED ON COMPONENT PRINTS... REFERENCE: 04687874... THIS IS A COMPUTER AIDED DESIGN DRAWING... CAD ID. NO. 5900 FILE NAME: H59000... NAME: CHART - ASSEMBLY DRAWING NO. REV U... PART NUMBER PART NUMBER REV DATE REV DRAWING NUMBER CUSTOMER... PART NUMBER F.C.I. CUSTOMER

MATING PART NUMBER CHART table with columns for DCA APPLICATION, FCI P/N'S, DCA P/N'S, YNA P/N'S, and MATING ASSEMBLY PART NUMBERS.

CHART-ASSEMBLY PART NUMBERS table with columns for UNSEALED and SEALED parts, categorized by W/O CPA, W/CPA, and W/O CPA.

CHART - ASSEMBLY PART NUMBERS table with columns for DCA APPLICATION, FCI P/N'S, DCA P/N'S, YNA P/N'S, and MATING ASSEMBLY PART NUMBERS.

FCI 52772 OR 52772 H SEE CHART VENDOR VENDOR CODE P/N

PART NUMBER PART NUMBER REV DATE REV DRAWING NUMBER CUSTOMER

PART NUMBER PART NUMBER REV DATE REV DRAWING NUMBER CUSTOMER