

SCALE 1:1

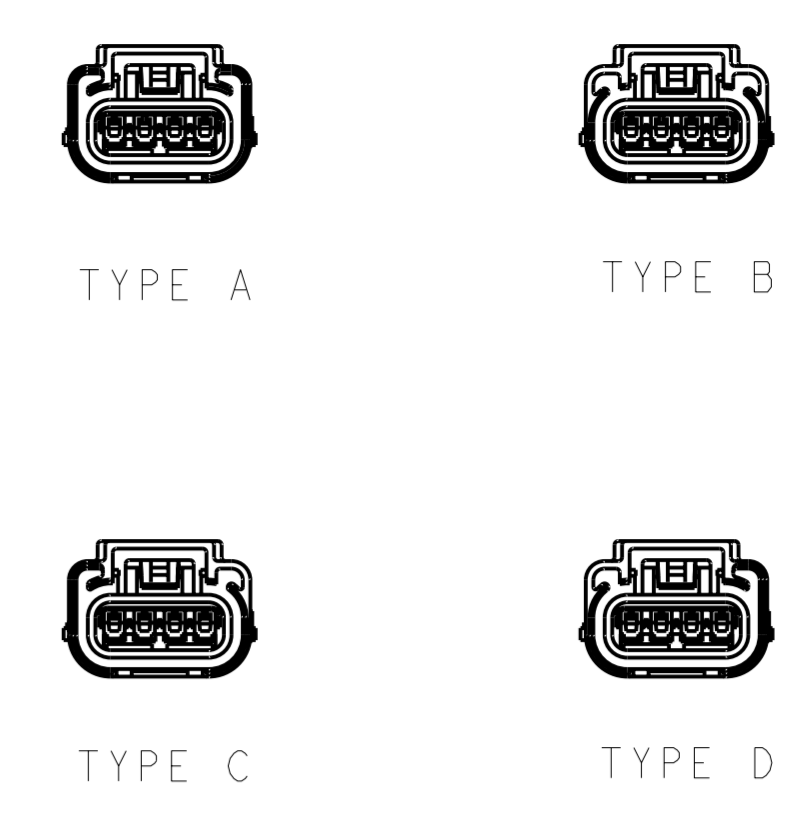

POLARIZATION OPTIONS SCALE 1:1

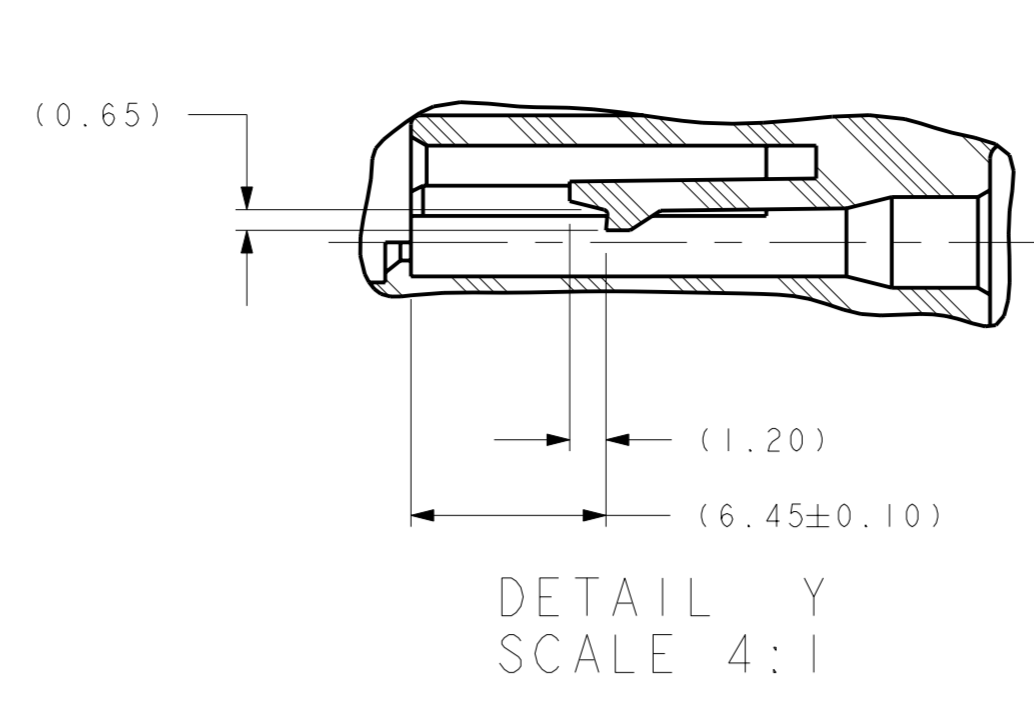
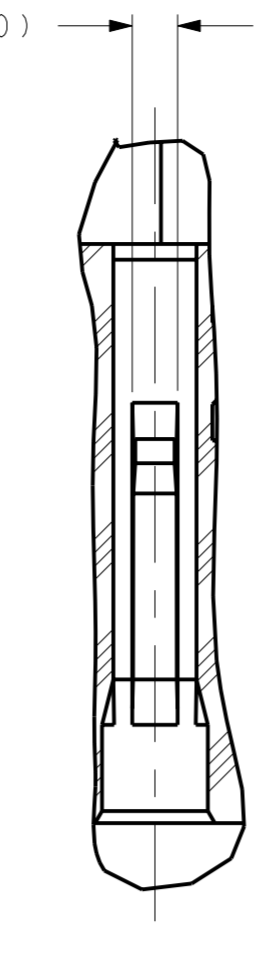
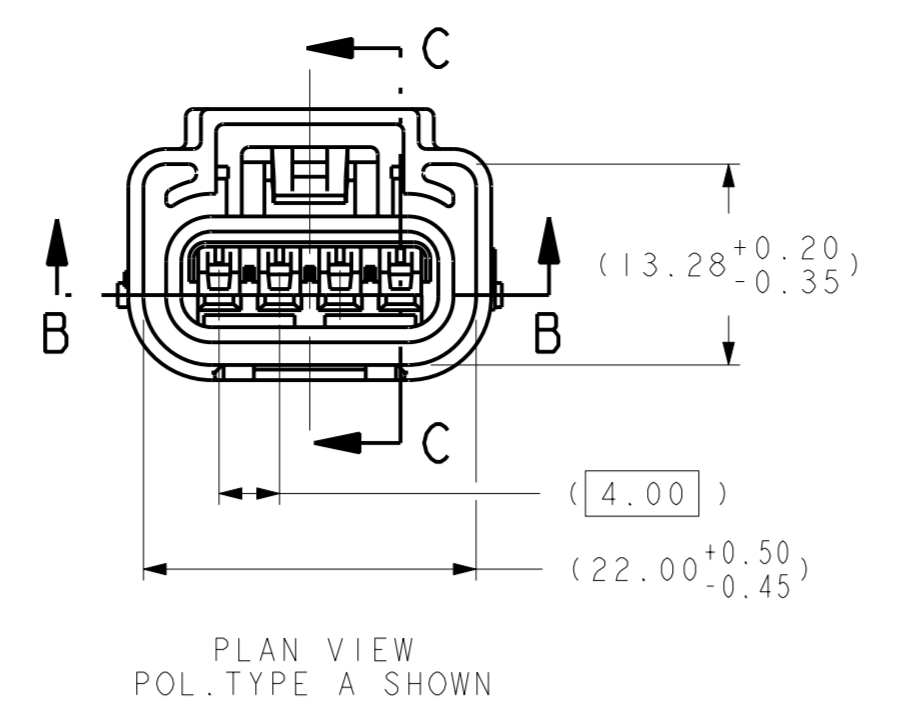
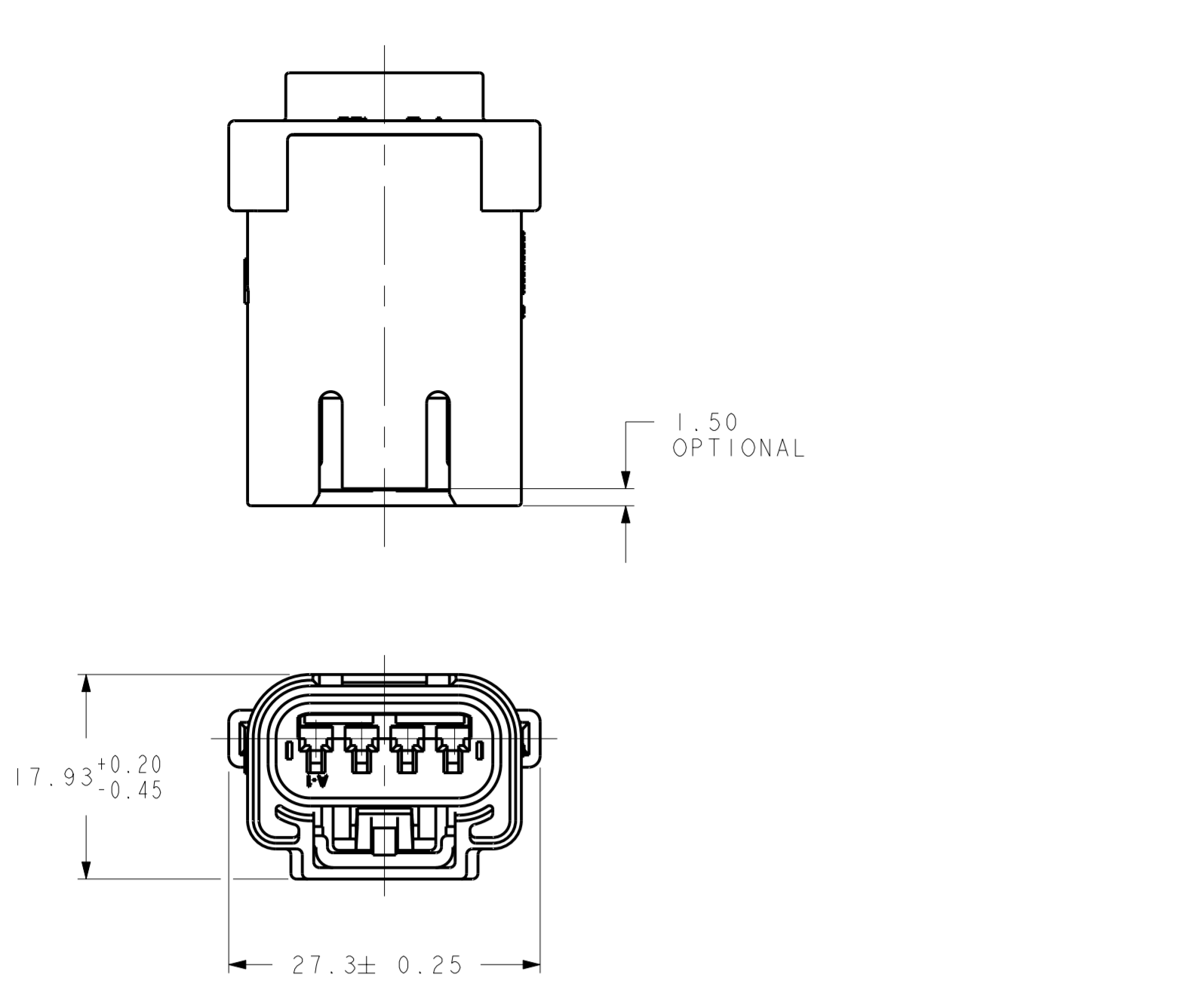
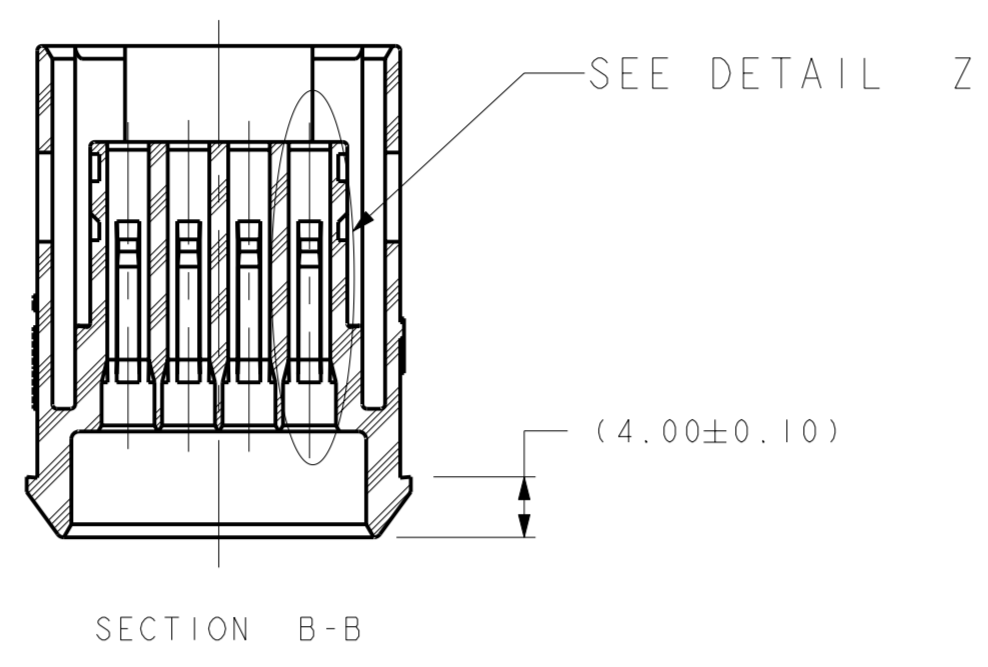

DETAIL Z SCALE 4:1

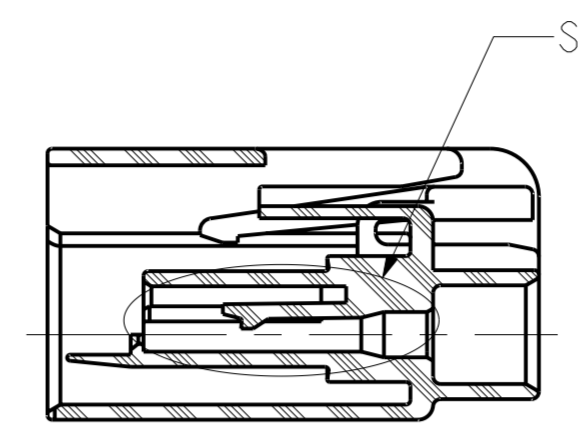

SECTION C-C

INSULATOR VIEWS (FOR REFERENCE ONLY)

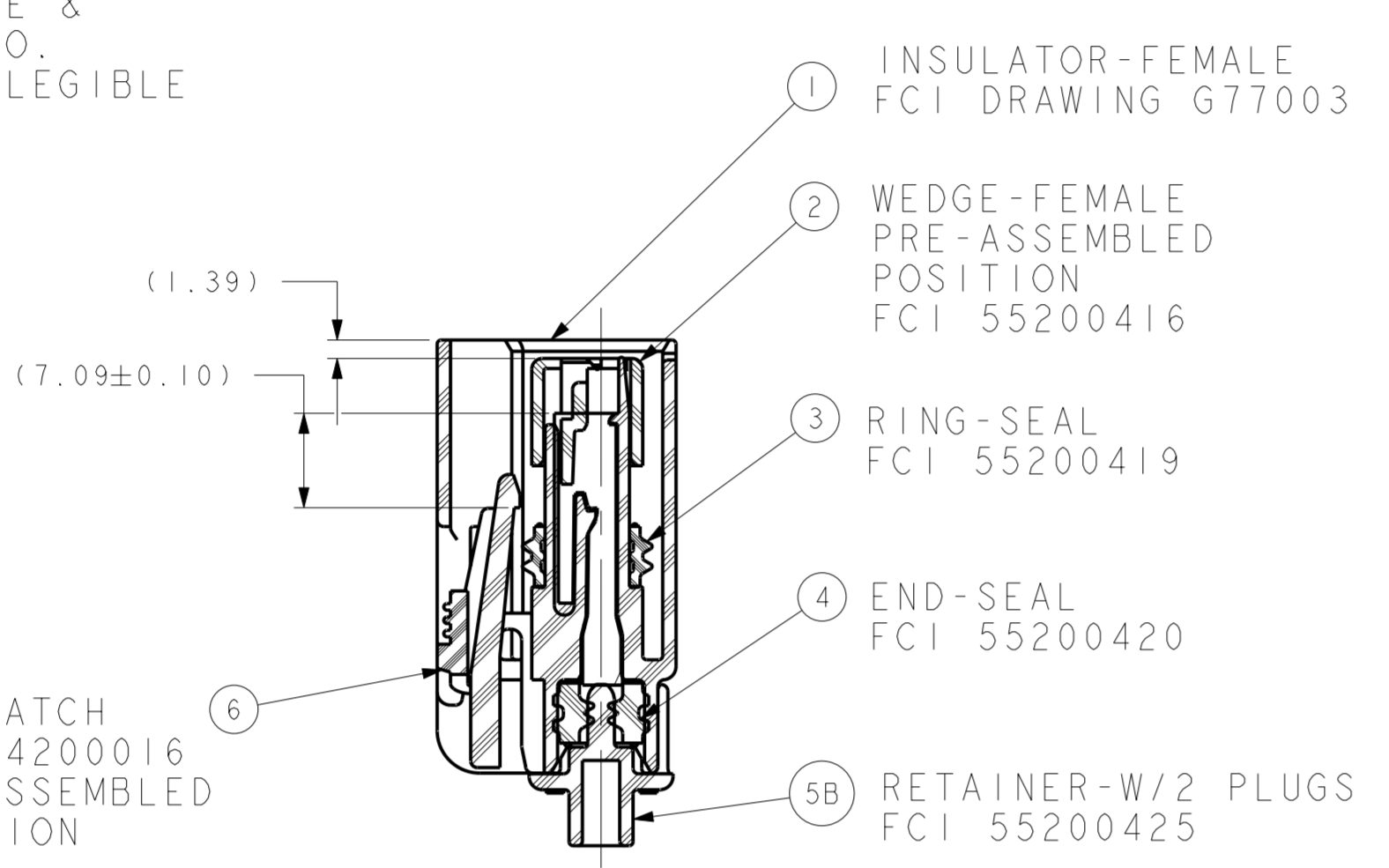
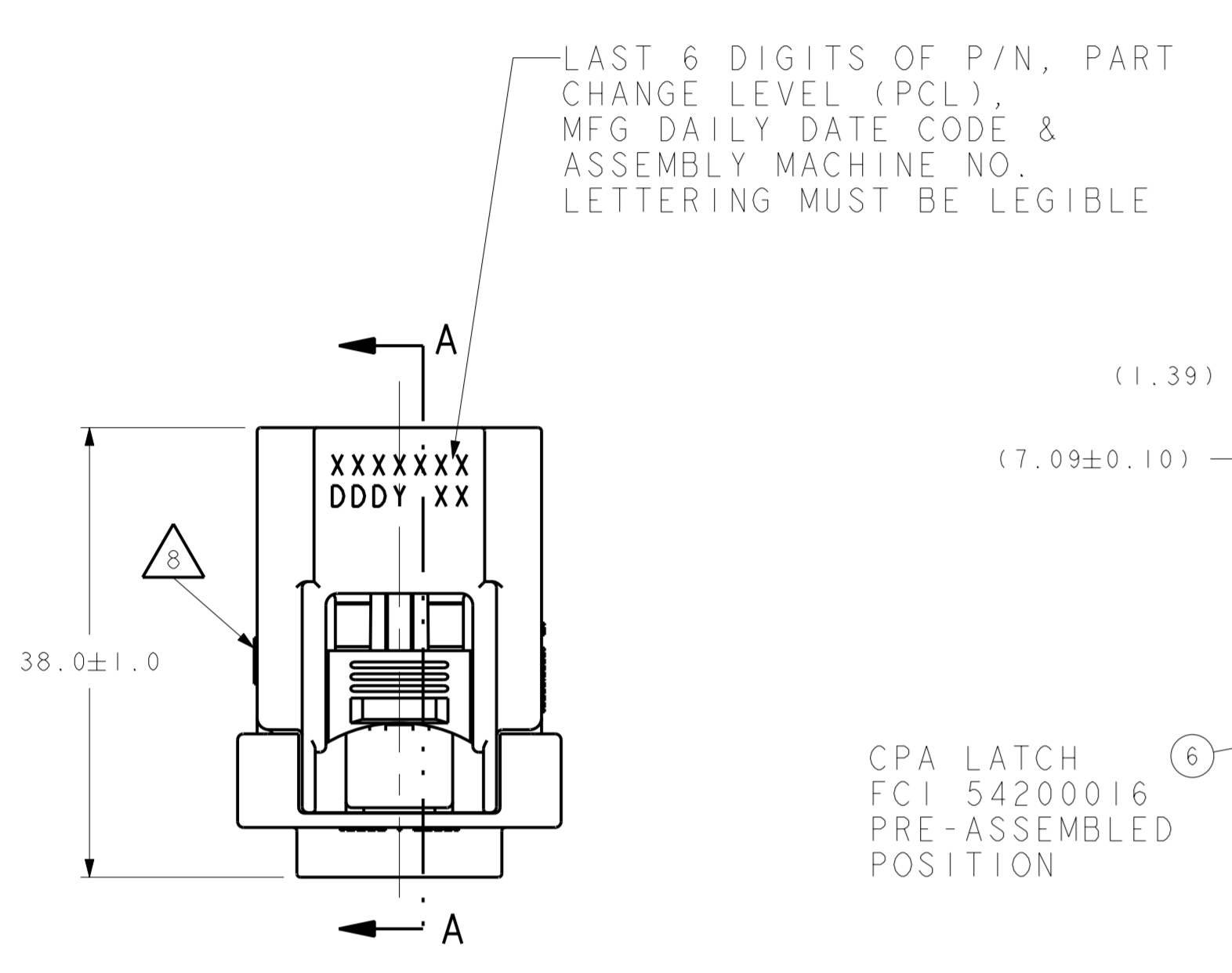

SECTION A-A SEALED ASSEMBLY VIEW FOR REFERENCE ONLY

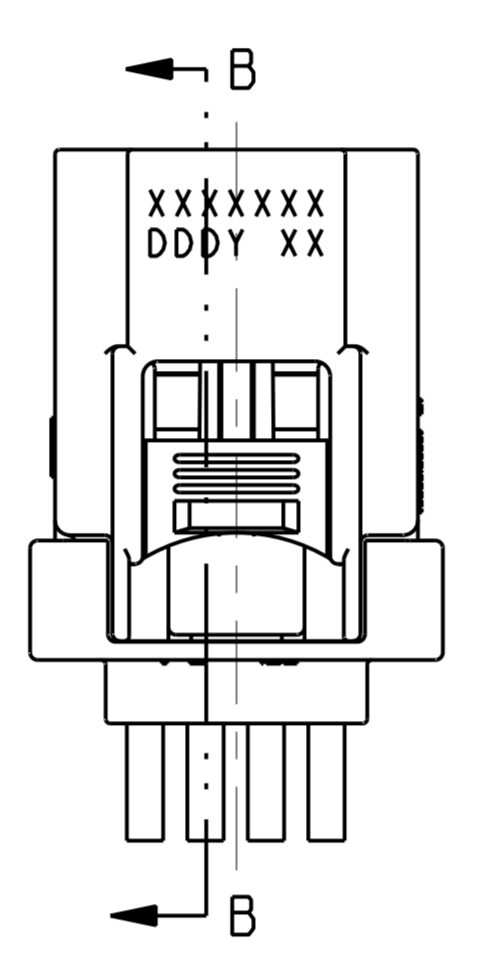

SECTION B-B SEALED ASSEMBLY VIEW FOR REFERENCE ONLY

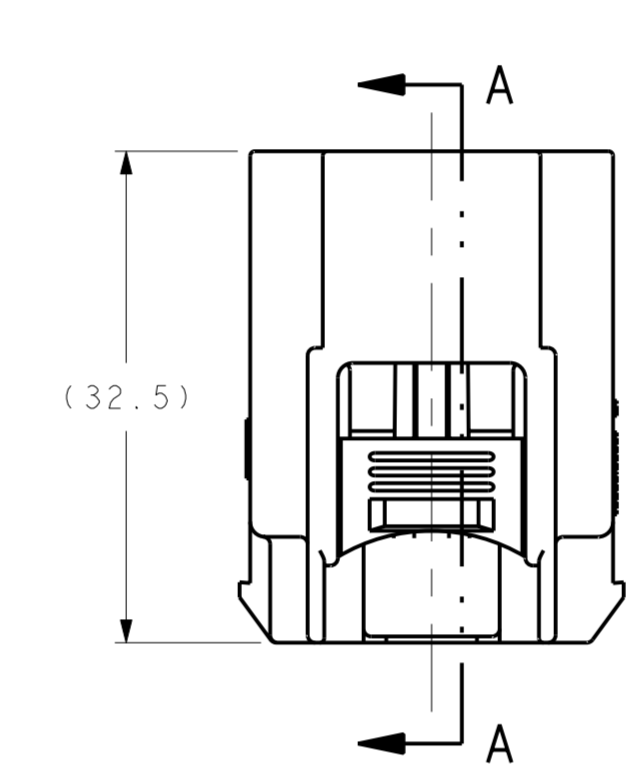

UNSEALED ASSEMBLY VIEW

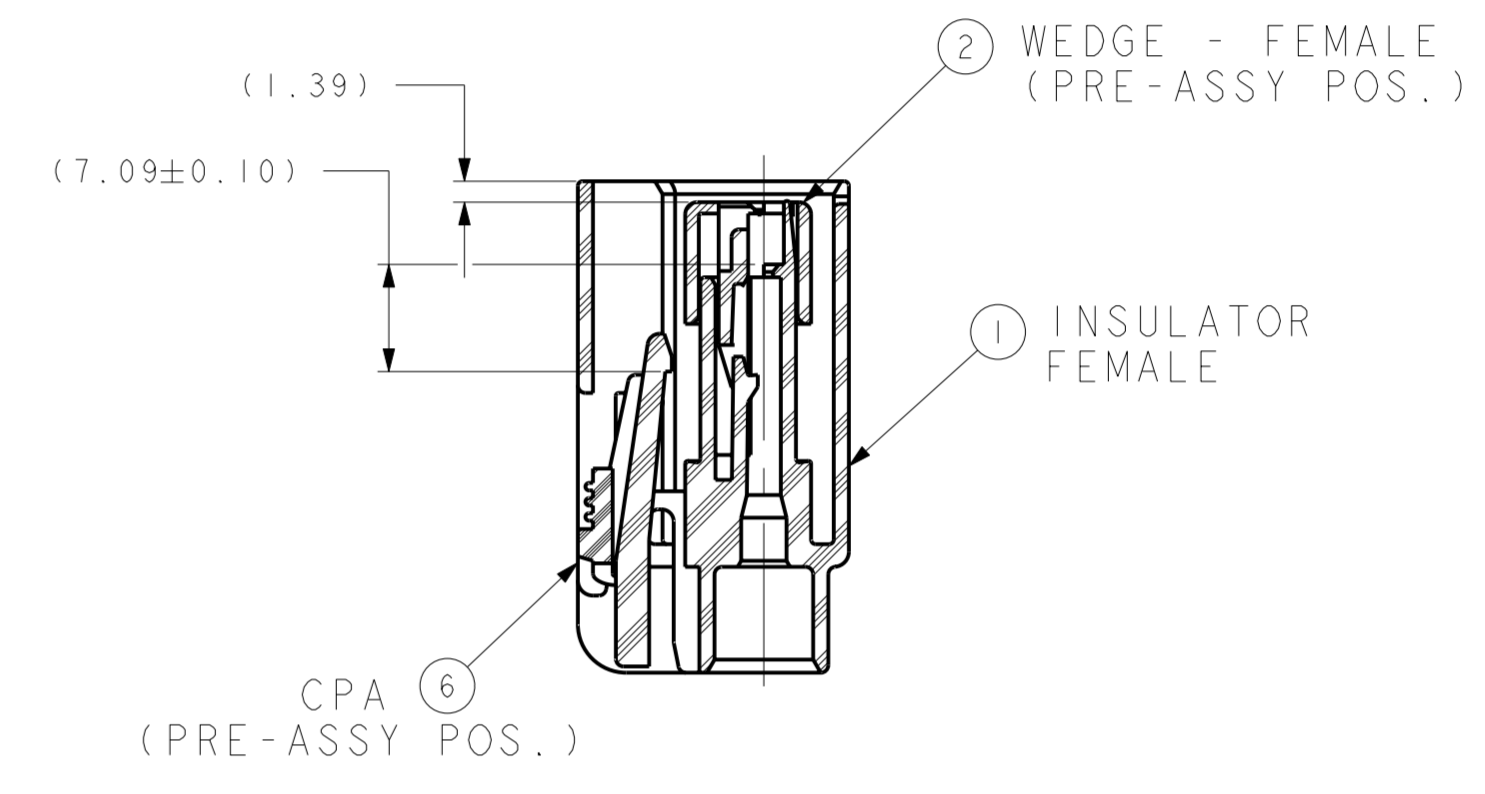

SECTION A-A

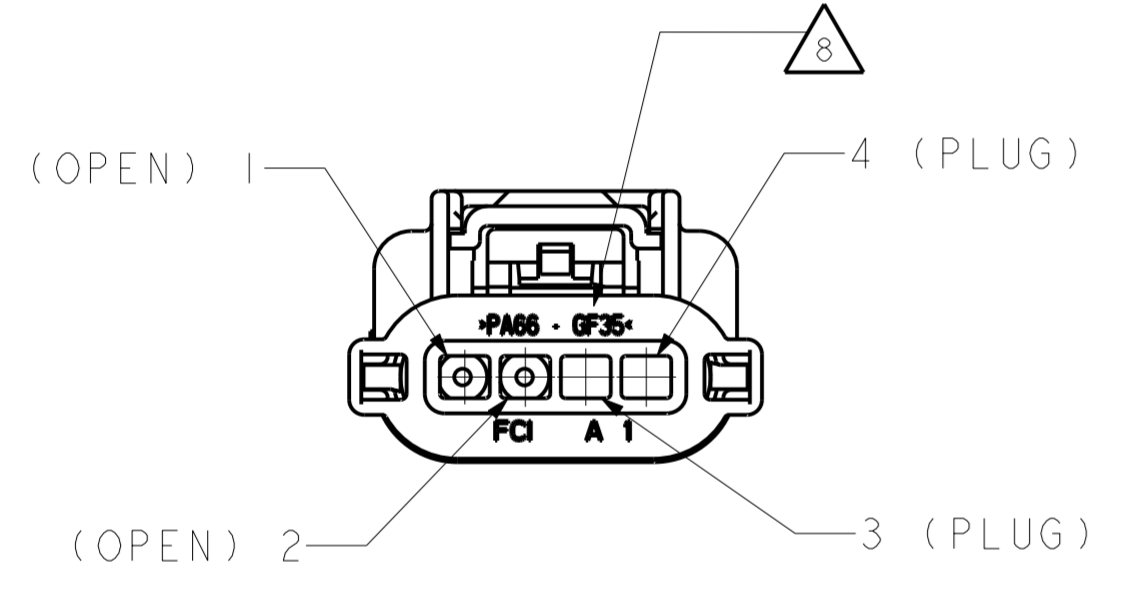

#1 SRS OPTION CIRCUIT #1 & 2 OPEN CIRCUIT #3 & 4 PLUGGED (UNSEALED ALL CAVITIES OPEN)

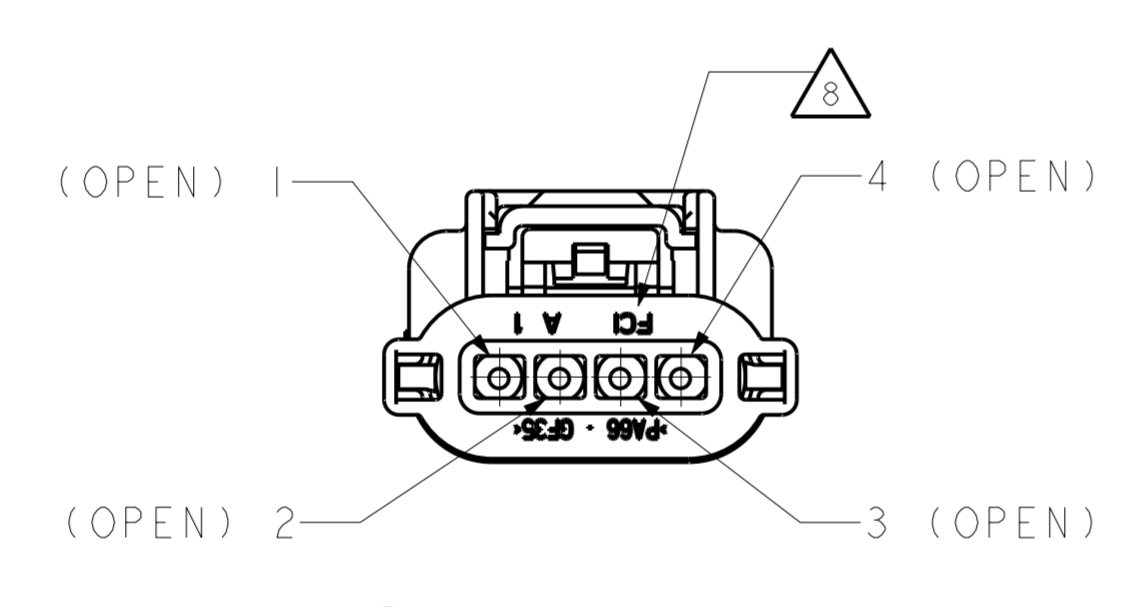

#2 SRS OPTION ALL CIRCUITS OPEN (UNSEALED ALL CAVITIES OPEN)

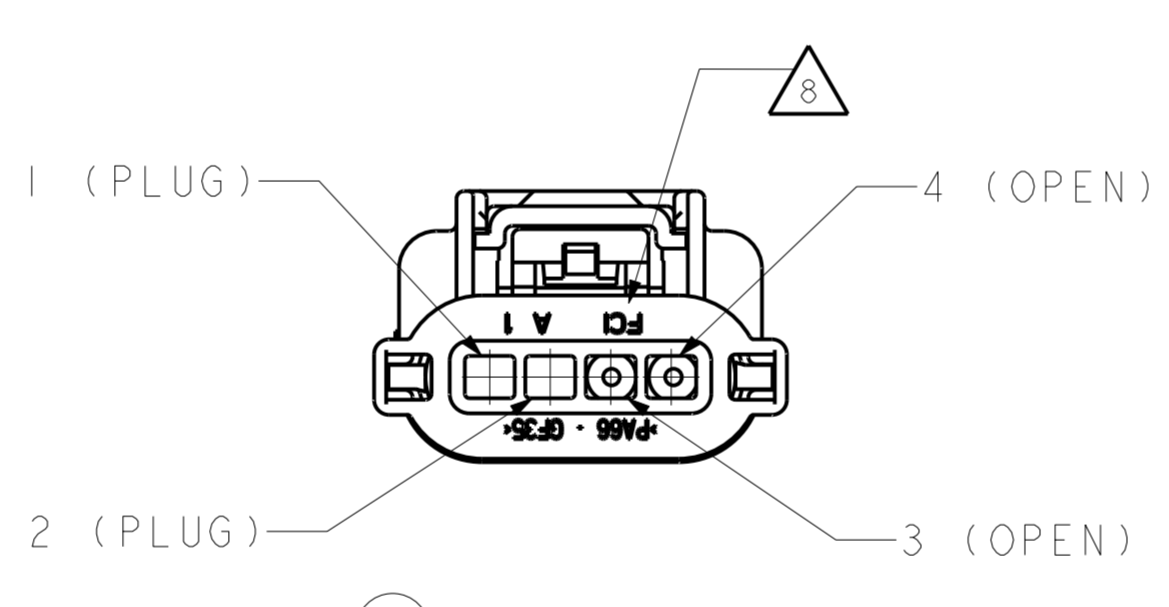

#3 SRS OPTION CIRCUIT #1 & 2 PLUGGED CIRCUIT #3 & 4 OPEN (UNSEALED ALL CAVITIES OPEN)

NOTES:

- QUALITY ASSURANCE REQUIREMENTS PER CHRYSLER PS-7300 SPC DATE REQUIRED
- ENGINEERING APPROVAL OF SUPPLIER SAMPLES IS REQUIRED PRIOR TO AUTHORIZATION OF PART PRODUCTION
- CHANGES IN DESIGN COMPOSITION OR PROCESSING FROM THE PART PREVIOUSLY APPROVED FOR PART PRODUCTION REQUIRES PRIOR ENGINEERING APPROVAL
- WIRING FABRICATIONS MUST SPECIFY PROPER INSULATION TYPE FOR TEMPERATURE CLASS THE CONNECTOR SYSTEM IS USED FOR
- ALL THE SEALED CONNECTOR APPLICATIONS MUST BE USED WITH CHRYSLER WIRE SPECIFICATION MSB288, MS9502 OR MS7889 20, 18, OR 16 GAGE WIRES ONLY UNLESS OTHERWISE SPECIFIED (WIRE INSULATIONS Ø1.50 MINIMUM TO Ø2.41 MAXIMUM)
- ALL NON-SEALED APPLICATIONS MAY BE USED WITH ANY WIRE INSULATION 22 GAGE THROUGH 14 GAGE (EXCEPT AS NOTED) PROVIDING THAT A TERMINAL GRIP FOR THAT CORE/INSULATION COMBINATION IS SHOWN ON THE FEMALE TERMINAL DRAWING
- MAXIMUM INSULATION CRIMP WIDTH = 3.30  
MAXIMUM INSULATION CRIMP HEIGHT = 2.80  
MAXIMUM INSULATION DIAMETER = 2.65
- TEST METHOD PER SAE/USCAR-2 REV 5 CONNECTOR ENGAGE & DIS-ENGAGE WITH LATCH DEPRESSURE FORCE NOT TO EXCEED 75N FOR THIS SYSTEM
- CPA SEATING FORCES - 40N MAXIMUM  
WEDGE SEATING FORCES- 75N MAXIMUM
- SUPPLIER, MOLD & CAVITY I.D. SIGNIFIES TOOL OWNERSHIP, FOR REFERENCE
- ANNUAL QUALITY REQUIREMENTS:  
IT IS PERMISSIBLE TO PERFORM CONTINUOUS CONFORMANCE PER FC1 SPECIFICATION #80A-001 INSTEAD OF ANNUAL LAYOUT & ANNUAL PV REQUIREMENTS OF QS 9000 SECTION 2 & SAE/USCAR-2 REV 5
- ALL NON-REFERENCE DIMENSIONS ARE REQUIRED
- MUST CONFORM TO THE FOLLOWING CHRYSLER/YNA STANDARDS:  
SAE/USCAR-2 REV 3 EXCEPT AS NOTED ABOVE  
PS- 7300 QUALITY ASSURANCE (CHRYSLER)  
PS- 4480 - CER- 4 (CHRYSLER) PART I.D., (G- 009- 2 YNA)  
PS- 9227 DATA EXCHANGE (CHRYSLER), (G- 009- 7 YNA)  
PS- 10052 INFORMATION SECURITY (CHRYSLER)
- USE WITH: CAVITY PLUG- FC1 P/N 54399002 WHEN REQUIRED  
USE WITH 1.5MM APEX FEMALE TERMINAL SEE C18001-CUST  
TERMINAL IS SYMMETRICAL AROUND CENTERLINE HAS 180° ORIENTATION CAPABILITY
- RETAINER P/N 55200425 IS NOT POLARIZED AND IT MUST HAVE PROPER PLUG LOCATION FOR SINGLE SHORTING CLIP OR 2-WAY APPLICATION  
SEE SAFETY RESTRAINT SYSTEM (SRS) OPTION VIEWS AND CHART

CHART- ASSEMBLY PART NUMBERS

UN-SEALED		SEALED	
IN-LINE	SRS APPLICATION	IN-LINE	
55200430			
55200431			
55200432			
55200433			
54550411			
54550410			
54550408			
54550406			
54550415			
54550420			
55200400			
55200402			
55200403			

FCI	INSULATOR	WEDGE	RING SEAL	END SEAL	RETAINER	CPA LATCH	W/O CLIP	IN-LINE	NO	LT YELLOW	BRT YELLOW	NATURAL	DK GRAY	LT GRAY	BLACK
54550410	A	54550421	#3	W/CLIP	NO	BRT YELLOW									
54550411	B	54550418	#1	W/CLIP	NO	LT YELLOW									
54550410	A	54550414	#1	W/CLIP	NO	BRT YELLOW									
54550411	B	F288110	#2	W/O CLIP	NO	LT YELLOW									
54550410	A	F188110	#2	W/O CLIP	NO	BRT YELLOW									
54550410	A	54550413	#2	W/CLIP	NO	BRT YELLOW									
54550405	B	F088110	#1	W/O CLIP	YES	LT YELLOW									
54550405	B	54550412	#1	W/CLIP	YES	LT YELLOW									
54550408	B	F978110	#2	W/O CLIP	YES	LT YELLOW									
54550408	B	54550407	#2	W/CLIP	YES	LT YELLOW									
54550406	A	F878110	#1	W/O CLIP	YES	BRT YELLOW									
54550406	A	54550409	#1	W/CLIP	YES	BRT YELLOW									
54550415	A	F778110	#2	W/O CLIP	YES	BRT YELLOW									
54550415	A	54550416	#2	W/CLIP	YES	BRT YELLOW									
54550420	A	F398110	#3	W/O CLIP	YES	BRT YELLOW									
54550420	A	54550419	#3	W/CLIP	YES	BRT YELLOW									
55200433	D	55200437		IN-LINE	NO	NATURAL									
55200432	C	55200436		IN-LINE	NO	DK GRAY									
55200431	B	55200435		IN-LINE	NO	LT GRAY									
55200430	A	55200434		IN-LINE	NO	BLACK									
55200403	D	55200407		IN-LINE	YES	NATURAL									
55200402	C	55200406		IN-LINE	YES	DK GRAY									
55200401	B	55200405		IN-LINE	YES	LT GRAY									
55200400	A	55200404		IN-LINE	YES	BLACK									

REQUIRED	REQUIRED	ITEM	FCI	P/N'S	PART NAME	COLOR	MATERIAL
		1		55200412	INS POL TYPE "A"	BRT YELLOW	A3EG7
		1		55200413	INS POL TYPE "B"	LT YELLOW	A3EG7
		1		55200408	INS POL TYPE "A"	BLACK	A3EG7
		1		55200409	INS POL TYPE "B"	LT GRAY	A3EG7
		1		55200410	INS POL TYPE "C"	DK GRAY	A3EG7
		1		55200411	INS POL TYPE "D"	NATURAL	A3EG7
		2		55200416	WEDGE-FEMALE	ROYAL BLUE	A3EG7
		3		55200419	RING SEAL	BRT RED	SILICONE
		4		55200420	END SEAL	BURNT ORANGE	SILICONE
		5A		55200418	RETAINER - NO PLUGS	NATURAL	A3EG7
		5B		55200425	RETAINER WITH TWO PLUGS SEE ASSY OPTION 1 & 3 FOR PLUGS LOCATION	BLACK	A3EG7
		6		54200016	CPA LATCH	RED	A3EG7

CONN ASSY TEMPERATURE CLASS PER SAE/USCAR-2 REV 5 PART CHANGE LEVEL (PCL)

REV	DATE	BY	REASON	REV	DATE	BY	REASON
1	07-01-06	RAZUMAR	4-WAY FEMALE SHORTING BAR/FIR-LINE	1	07-01-06	RAZUMAR	4-WAY FEMALE SHORTING BAR/FIR-LINE