

REVISIONS			
REV.	DESCRIPTION	DATE	APPROVED
A	INITIAL RELEASE	09/29/11	D.N.

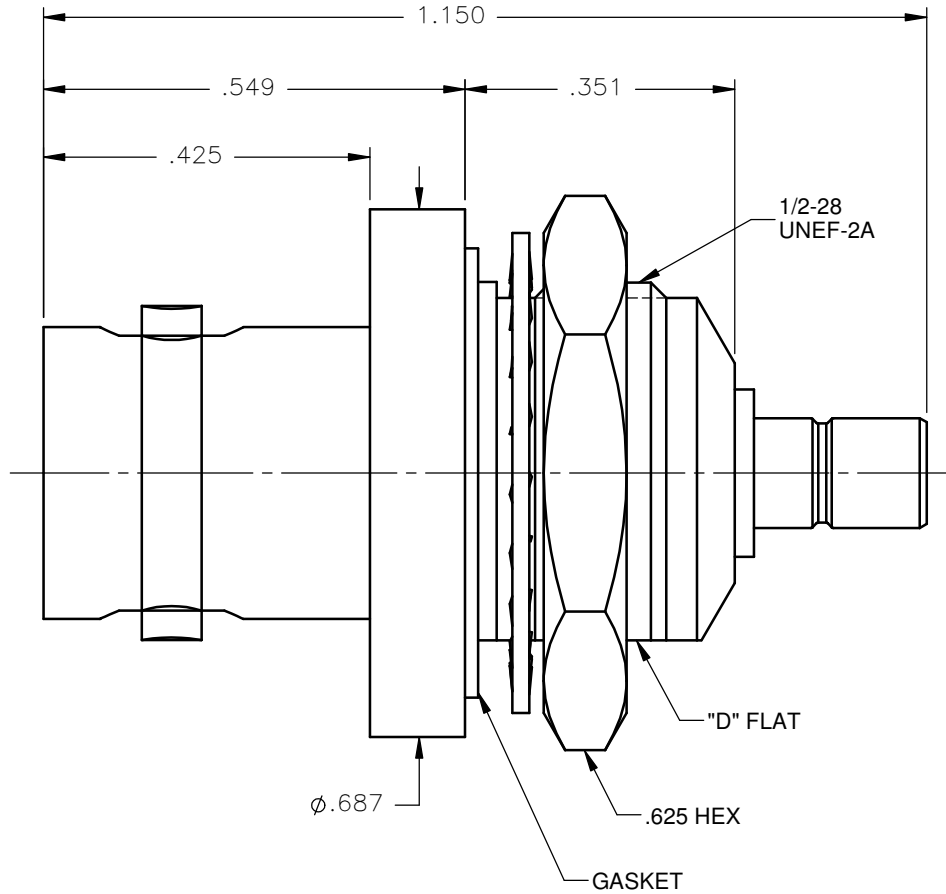



NOTES:

MATERIALS:

1. INSULATORS = VIRGIN WHITE TEFLON PER ASTM D1710, GRADE 1, TYPE I, CLASS "B".
2. BNC CONTACT = BERYLLIUM COPPER PER ASTM B196, ALLOY C17300, TEMPER TD04.
3. GASKET = SILICONE RUBBER 45-55 DUROMETER DOW CORNING SILASTIC 250.
4. LOCKWASHER = PHOSPHOR BRONZE PER ASTM B139, COPPER ALLOY C53400, TEMPER H04.
5. ALL OTHER METAL PARTS = BRASS PER ASTM B16, ALLOY C36000, TEMPER H02.

FINISHES:

1. CONTACTS = GOLD PLATE PER MIL-G-45204, TYPE II, CLASS 1, GRADE C, OVER .00010 TO .00020 STRESS FREE SULFAMATE NICKEL PER QQ-N-290.
2. ALL OTHER METAL PARTS = NICKEL PLATE PER QQ-N-290, CLASS 1, GRADE G, EXCEPT .0001 TO .0002 THICK OVER .00005 TO .0001 THICK COPPER PER MIL-C-14550.

UNLESS OTHERWISE SPECIFIED DIMENSIONS ARE IN INCHES TOLERANCES ON	DWN: DATE	 Property of Radiall This document cannot be reproduced or communicated to a third party without prior written permission of RADIALL.			
	D.N. 09/29/11				
DECIMAL	ANGLE	CHKD: DATE	BNC BULKHEAD FEMALE JACK TO SMB MALE JACK ADAPTER		
		J.S. 09/29/11			
		APVD: DATE			
		J.M. 09/29/11			
REFERENCE:	MATERIALS & FINISHES:	SIZE	FSCM NO.	DWG NO.	REV
ORIGINATED: D.N. DATE: 09/29/11	SEE NOTES	A	19505	5512-7501-000	A
		SCALE 4:1	THIRD ANGLE PROJECTION		SHEET 1 OF 1

5512-7501-000