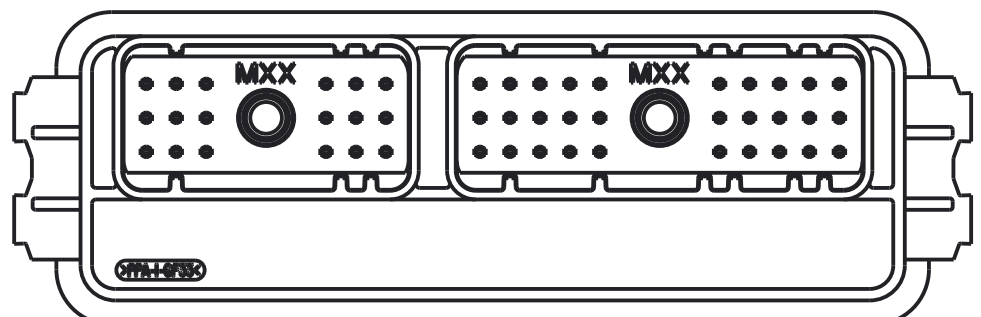
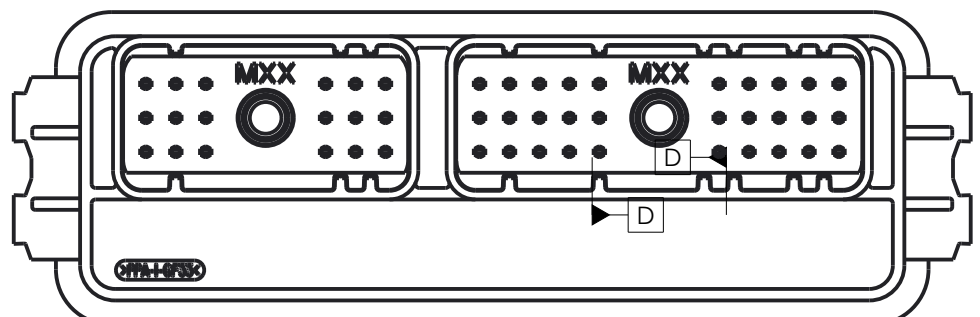
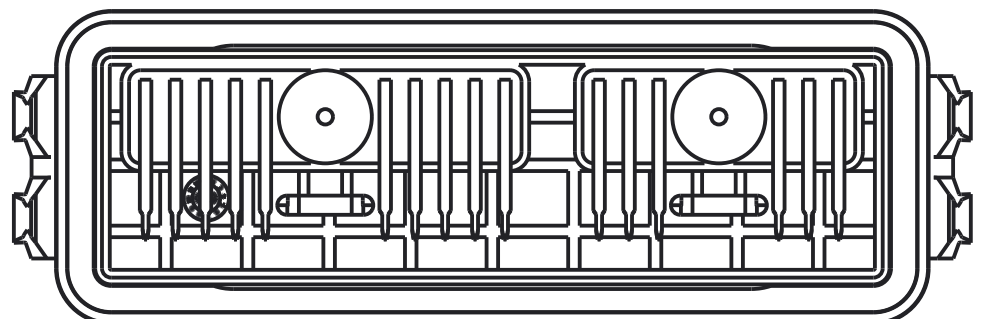
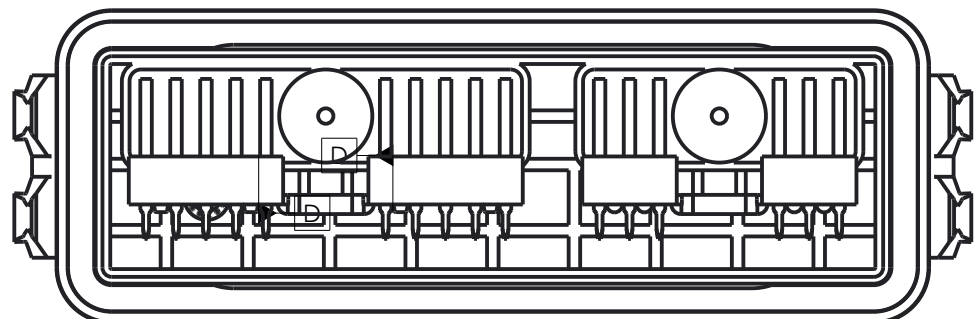

CINCH PART NUMBER MATRIX

P/N: 5810148009	P/N: 5810148010
48-WAY HEADER ASSEMBLY WITHOUT FERRITE FILTERS	48-WAY HEADER ASSEMBLY WITH FERRITE FILTERS
	
	
MATES WITH CINCH HARNESS CONNECTORS P/N: 5810118023 (18-WAY) AND 5810130029 (30-WAY)	

DRAWING REVISIONS (RELEASE DATE ON FILE)			
REV	DOCUMENT	APP	APPROVAL DATE
C	CO 3274	KR	7/18/16

NOTES:

- ALL DIMENSIONS ARE IN INCHES; DIMENSIONS INSIDE [.XX] ARE IN mm, AS REFERENCE ONLY
- MATERIALS:
 INTERFACE SEALS: SILICONE RUBBER, COLOR BLUE
 INSULATOR: 30% GLASS FILLED POLYMER, COLOR BLACK
 BUSHINGS: BRASS ALLOY, UNPLATED 10-24 UNC THREAD
 TERMINAL BLADES: 1.5 mm BRASS WITH TIN OVER NICKEL PLATING
 FILTERS: FERRITE BLOCKS
- ALL HEADERS ARE REFLOW OR WAVE SOLDERING PROCESS, ROHS COMPLIANT
- SUGGESTED PCB THICKNESS: .062 [1.57]
- IF USING FERRITE FILTER VERSION, TRACES SHOULD BE AVOIDED UNDER THE FERRITE SPACER FEET. SEE "PCB TOP SIDE PIN AREA WITH FERRITES DETAIL" - PAGE 3.
- MATES WITH CINCH SHS PUSH-TO-SEAT HARNESS CONNECTORS (SEE TABLE ABOVE)
- TORQUE MATING CONNECTOR SCREW TO 15 - 20 IN*lbs [1.70 - 2.26 N*m]

UNITS ENGLISH INCHES		DESIGN ENGINEER A. ECKHART	DATE 4/3/09	MODELED BY: A. ECKHART 1700 FINLEY RD LOMBARD, IL. 60148	
DO NOT SCALE DRAWING		PRO/E		CINCH TITLE: 48-WAY HEADERS MODICE ME	
CONFIDENTIAL THIS DOCUMENT IS THE PROPERTY OF CINCH. NEITHER THIS DOCUMENT NOR ANY OF THE INFORMATION CONTAINED IN IT MAY BE DUPLICATED OR DISCLOSED WITHOUT PRIOR WRITTEN CONSENT OF CINCH. ©COPYRIGHT 2009 CINCH		APPROVALS ON FILE		MATERIAL: SEE NOTES CONTROL SPEC NUMBER:	
				MATERIAL SPEC NUMBER: FINISH: PROJECT NUMBER: A14926	
				CAD FILE NUMBER: 5810148009S DRAWING NUMBER: 5810148009S CAGE IDENT NO.: 71785 SIZE: B SCALE: 1:1 SHEET 1 OF 3	

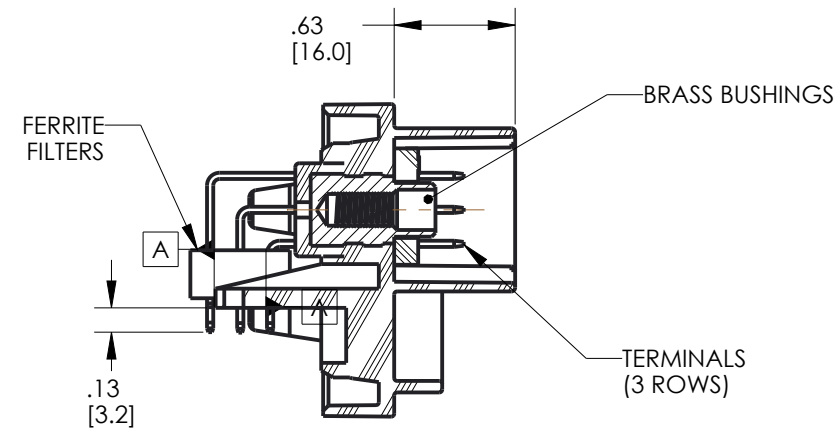

SECTION B-B

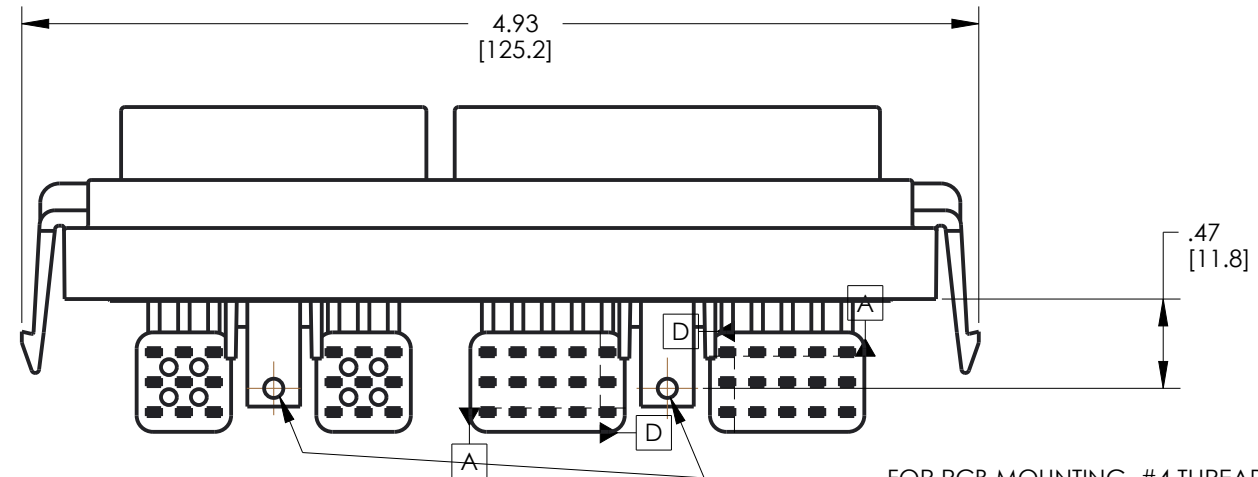
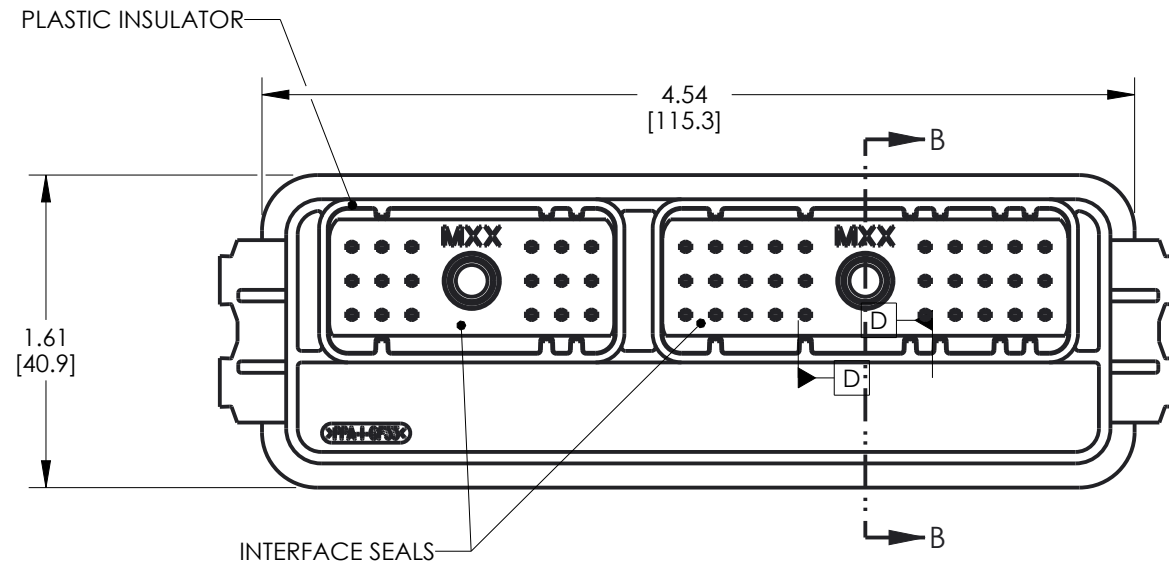
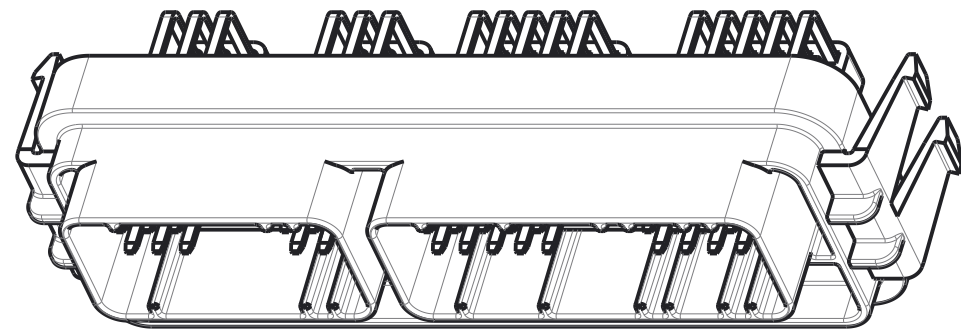

CINCH P/N: 5810148010 SHOWN
(HEADER WITH FILTERS)

FOR PCB MOUNTING, #4 THREAD CUTTING SCREWS (TYPE 23 OR SIMILAR) ARE RECOMMENDED; TORQUE TO 2-3 IN*LBS [0.23-0.34Nm]

UNITS ENGLISH INCHES	CINCH		1700 FINLEY RD LOMBARD, IL. 60148
DO NOT SCALE DRAWING	TITLE 48-WAY HEADERS MODICE ME		
CONFIDENTIAL THIS DOCUMENT IS THE PROPERTY OF CINCH. NEITHER THIS DOCUMENT NOR ANY OF THE INFORMATION CONTAINED IN IT MAY BE DUPLICATED OR DISCLOSED WITHOUT PRIOR WRITTEN CONSENT OF CINCH. ©COPYRIGHT 2009 CINCH	DRAWING NUMBER 5810148009S		REV C
	CAD FILE NUMBER 5810148009S	DRAWING NUMBER 5810148009S	
	CAGE IDENT NO. 71785	SIZE B	SCALE 1:1
	SHEET 2 OF 3		