

## Description

Three pole, miniaturised, aircraft style thermal circuit breaker with tease-free, trip-free, snap action mechanism and push/pull on/off manual actuation (M-type TO CBE to EN 60934). An indicator band on the push button clearly shows the tripped/off position. Threadneck panel mounted, available in metric and US (AS 14154) configurations. Advanced two-chamber design minimises contact contamination to provide fail-safe operation. Temperature compensated with optional auxiliary contacts, and fully approved for use on a wide range of aircraft and equipment.

Various dummies are available without protective function, allowing connection of pre-installed wiring without loads.

## Typical applications

Aircraft systems and equipment (fixed wing and helicopters); other extra low voltage wiring applications; defence equipment; communications systems.

## Standard current ratings and typical volt drop values

Current rating (A)	Volt drop per pole (mV)	Current rating (A)	Volt drop per pole (mV)
1	750	7.5	230
2	520	10	190
2.5	400	15	190
3	360	20	200
4	350	25	170
5	260	30	160

## Approvals

Authority	Standard	Voltage ratings	Current ratings
Bw	VG 95345, part 11	AC 115/200 V, 400 Hz DC 28 V	1 A...25 A 1 A...25 A
Bw	LN 29887	AC 115/200 V, 400 Hz	5 A...25 A
Dep. of the Navy	AS14154	AC 115/200 V, 400 Hz	1 A...20 A
QPL Canada Dep. of National Defence	VG 95345, part 11	AC 115/200 V, 400 Hz DC 28 V	1 A...25 A 1 A...25 A
QPL Sweden Defence Material Admin.	LN 29887 MS 14154	AC 115/200 V, 400 Hz DC 28 V	1 A...25 A 1 A...25 A
QPL UK Ministry of Defence	LN 29887	AC 115/200 V, 400 Hz	5 A...25 A
Airbus	EN 2996-004	AC 115/200 V, 400 Hz	1 A...25 A
Airbus	EN 2996-005	AC 115/200 V, 400 Hz	1 A...25 A



## Technical data

For further details please see: [www.e-t-a.de/ti\\_e](http://www.e-t-a.de/ti_e)

Voltage rating	3 AC 200 V (300 Hz to 800 Hz); DC 28 V	
Current rating range	1...30 A	
Auxiliary circuit	0.5 A, DC 28 V	
Typical life	20,000 operations mechanical 10,000 operations at $I_N$ ( $\leq 25$ A) 4,000 operations at $I_N$ (30 A)	
Ambient temperature	-55...+125 °C (-67...+257 °F) $\leq 15$ A -55...+90 °C (-67...+194 °F) $> 15$ A	
Insulation co-ordination (IEC 60664 and 60664A)	rated impulse withstand voltage 1.5 kV	pollution degree 3
Dielectric strength (IEC 60664 and 60664A)	test voltage operating area pole/pole main to aux. circuit	AC 1,500 V AC 1,500 V AC 1,500 V
Insulation resistance	$> 100$ M $\Omega$ (DC 500 V)	
Interrupting capacity $I_{cn}$ 3 AC 200 V (400 Hz):	$\leq 4$ A 5 A 7.5...25 A 30 A	1,000 A 2,000 A 2,500 A 1,500 A
	DC 28 V:	1...25 A 30 A 4,000 A 6,000 A
Degree of protection (IEC 60529/DIN 40050)	operating area IP40 terminal area IP00	
Vibration (sinusoidal)	10 g (57-2000 Hz), $\pm 0.76$ mm (5-57 Hz) to VG 95210, sheet 19, IEC 60068-2-6, test Fc, ISO 7137	
Vibration (random)	16.4 g rms, 0.2 g <sup>2</sup> Hz $\pm 1.5$ dB, to VG 95210, sheet 29, IEC 60068-2-6, test Fc, ISO 7137	
Acceleration	17 g, to ISO 2669	
Shock	50 g (11 ms), to VG 95210, sheet 28, IEC 60068-2-27, test Ea, ISO 7137	
Corrosion	96 hours at 5 % salt mist 48 hours at 20 % salt mist to VG 95210, sheet 2, IEC 60068-2-11, test Ka, ISO 7137	
Humidity	240 hours at 95 % RH, to VG 95210, sheet 7, IEC 60068-2-3, test C/ISO 7137	
Explosion	to VG 95210, sheet 10, MIL-STD-202, meth. 109	
Altitude	$\leq 25,000$ m above sea level	
Mass	max. 67 g with auxiliary contact max. 63 g without auxiliary contact	
<b>Mass reduction through aluminium threadneck approx. 3 g</b>		

## Ordering information

### Type No.

583 three pole, with temperature compensation

### Mounting

G threadneck panel mounting

### Threadneck design

- 1 M12x1x6.4x8.8 dia. with mounting plate (aux. contact version)
- 3 MJ12x1x6.4x8.8 dia. (only without aux. contact)
- 4 M12x1x6.4x8.8 dia. (only without aux. contact)
- 5 7/16-32UNx6.4x7.8 (only without aux. contact)
- 7 7/16-32 UNx6.4x7.8 dia. with mounting plate (aux. contact version)
- 8 M12x1x6.4x8.8 with mounting plate, aluminium threadneck
- 9 M12x1x6.4x8.8, aluminium threadneck

### Hardware for threadneck (washers)

- 0 without hardware
- 1 corrugated washer 12/15, fitted
- 2 serrated lock washer 12.1/17.2, fitted
- 3 toothed washer 11.3/14.9, fitted
- 5 serrated lock washer 12.1/17.2, bulk shipped

### Hardware for threadneck (nuts)

- 0 without hardware
- 1 hex nut M12x1
- 3 hex nut 7/16-32UN
- 5 hex nut MJ12x1 (only with threadneck design 3)
- 7 hex nut M12x1, aluminium, bulk shipped

### Terminal design (main terminals)

- K screw terminals with metric thread
  - 1 K14 (M4, MJ4)
- J screw terminals with inch thread
  - 1 J14 (8-32UNC-2B)

### Characteristic curve

M1 thermal, 1.15-1.38 I<sub>N</sub>

### Terminal screws

- A Phillips screw M4x6
- B Phillips screw 8-32UNC-2Ax6 (MS 51957-41)
- K hex screw with Phillips head 8-32UNC-3Ax7.6
- L Phillips screw MJ4x6
- Z without accessories

### Terminal washers

- 0 without lock washer
- 1 lock washer B4
- 2 lock washer 4.3 (MS 35338-137)
- 5 lock washer 4.3/9

### Auxiliary contact

- S0 without auxiliary contact
- S1 with auxiliary contact (N/C) (connector to EN 3155-016M2018, size 20)
- S5 with polarized auxiliary contact (N/C)

### Barrier

- T barrier 25.5 mm wide, 37.7 mm long (-S0 only)
- U barrier 19.5 mm wide, 37.7 mm long
- X barrier 19.5 mm wide, 34.1 mm long

### Colour of the push button

- (blank) black (standard) (e.g. 7.5)
- G green to EN (e.g. 7 1/2)
- N black to EN (e.g. 7 1/2)

### Current ratings

1...30 A

583 - G 4 1 1 - K 1 M1 - A 1 S0 T . - 5 A ordering example

Please be informed that we have minimum ordering quantities to be observed.

## Ordering information for approved devices

### 583-G411-K1M1-A1S0TN (583-96-TC-K14)

Metric threadneck M12x1 and terminal design -K14 (M4x6), listed by the German Materialamt der Bundeswehr to VG 95345 T11.

### 583-G533-J1M1-B2S0XN (AS 14154)

Threadneck size 7/16-32UNSx6.4 and terminal design -J14 (inch thread 8-32), approved to AS 14154.

## Dimensions 583-G411-K1M1-A1S0TN (VG 95345 T11)

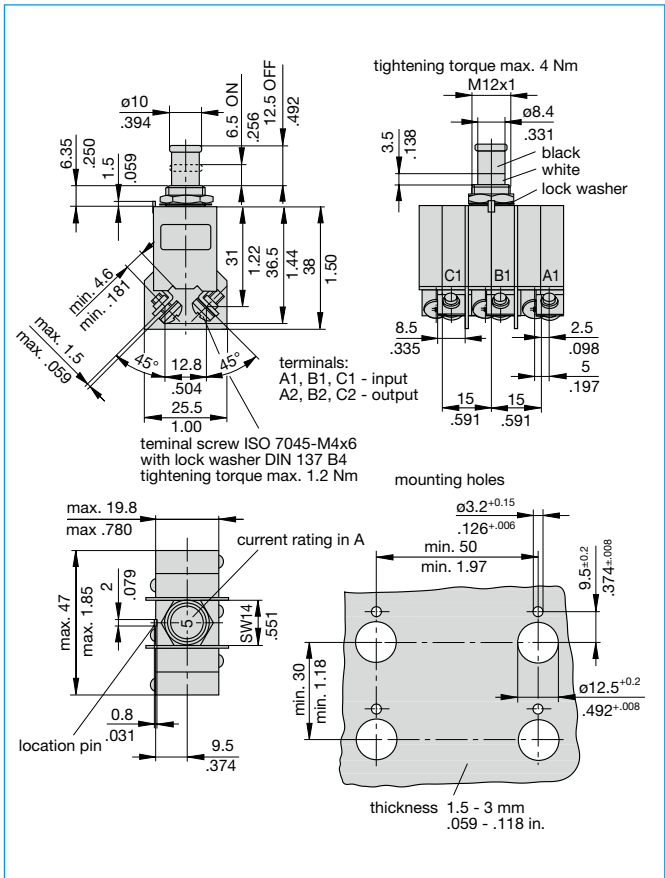

## Dimensions 583-G533-J1M1-B2S0XN (AS14154)

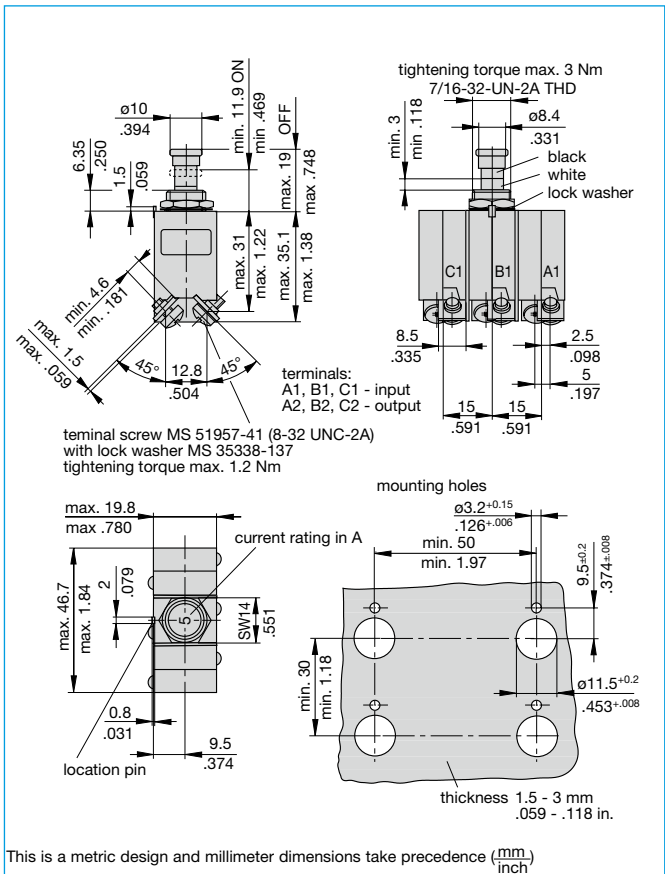

## Dimensions 583-G111-K1M1-A1S1UN (VG 95345 T11)

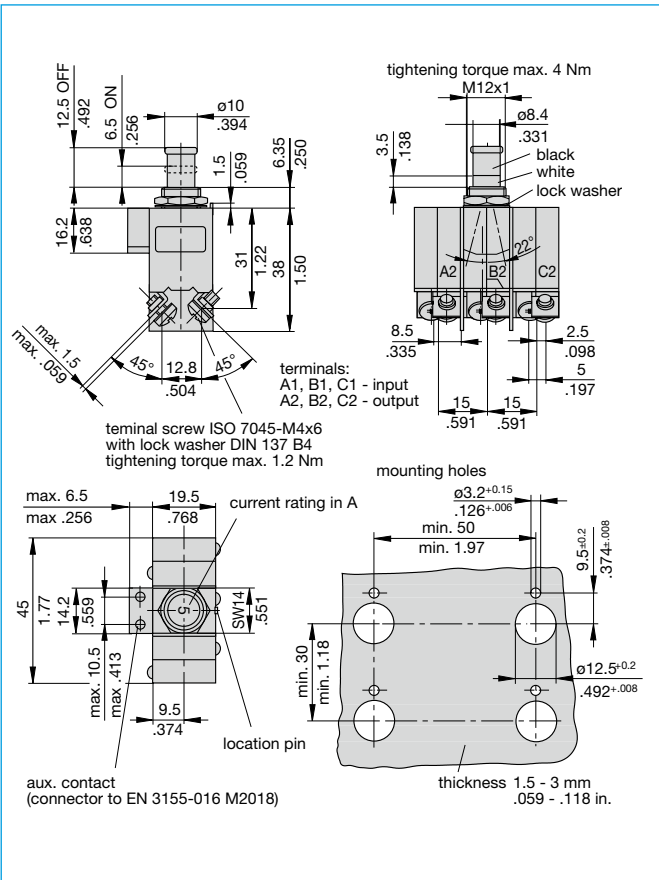

## Typical time/current characteristics

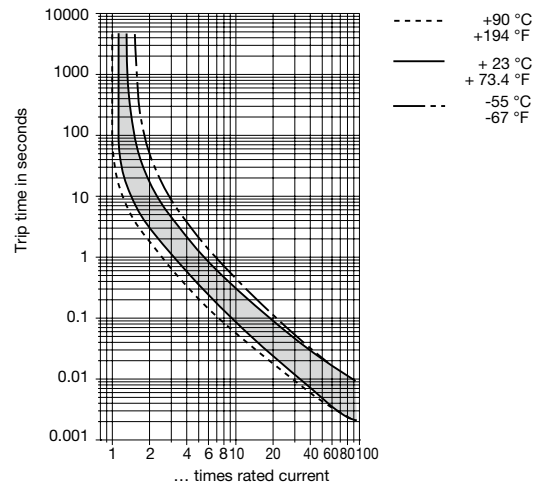

## Internal connection diagrams

