

6N140A, HCPL-675x, 83024, HCPL-570x, HCPL-177K, 5962-89810, HCPL-573x, HCPL-673x, 5962-89785, 5962-98002¹



Hermetically Sealed, Low I_F , Wide V_{CC} , High Gain
Optocouplers

Data Sheet

Description

These units are single, dual, and quad channel, hermetically sealed optocouplers. The products are capable of operation and storage over the full military temperature range and can be purchased as either commercial product or with full MIL-PRF-38534 Class Level H or K testing or from the appropriate DLA Standard Microcircuit Drawing (SMD). All devices are manufactured and tested on a MIL-PRF-38534 certified line, and Class H and K devices are included in the DLA Qualified Manufacturers List QML-38534 for Hybrid Microcircuits.

Each channel contains a GaAsP light emitting diode that is optically coupled to an integrated high gain photon detector. The high gain output stage features an open collector output, providing both lower saturation voltage and higher signaling speed than possible with conventional photo-Darlington optocouplers. The shallow depth and small junctions offered by the IC process provides better radiation immunity than conventional photo transistor optocouplers.

The supply voltage can be operated as low as 2.0V without adversely affecting the parametric performance.

These devices have a 300% minimum CTR at an input current of only 0.5 mA making them ideal for use in low input current applications such as MOS, CMOS, low power logic interfaces or line receivers. Compatibility with high-voltage CMOS logic systems is assured by specifying I_{CCH} and I_{OH} at 18 Volts.

CAUTION It is advised that normal static precautions be taken in handling and assembly of this component to prevent damage and/or degradation which may be induced by ESD.

1. See [Selection Guide—Package Styles and Lead Configuration Options](#) for available extensions.

Features

- Dual marked with device part number and DLA Standard Microcircuit Drawing (SMD)
- Manufactured and tested on a MIL-PRF-38534 Certified Line
- QML-38534, Class H and K
- Five hermetically sealed package configurations
- Performance guaranteed over full military temperature range: -55°C to $+125^{\circ}\text{C}$
- Low input current requirement: 0.5 mA
- High current transfer ratio: 1500% typical at $I_F = 0.5$ mA
- Low output saturation voltage: 0.11V typical
- 1500 Vdc withstand test voltage
- High radiation immunity
- 6N138/9, HCPL-2730/31 function compatibility
- Reliability data

Applications

- Military and aerospace
- High reliability systems
- Microprocessor system interface
- Transportation, medical, and life critical systems
- Isolated input line receiver
- EIA RS-232-C line receiver
- Voltage level shifting
- Isolated input line receiver
- Isolated output line driver
- Logic ground isolation
- Harsh industrial environments
- Current loop receiver
- System test equipment isolation
- Process control input/output isolation

Functional Diagram

Multiple channel devices available.



Package styles for these parts are 8-pin and 16-pin DIP through hole (case outlines P and E respectively), 16-pin DIP flat pack (case outline F), and leadless ceramic chip carrier (case outline 2). Devices may be purchased with a variety of lead bend and plating options. See [Selection Guide–Package Styles and Lead Configuration Options](#) for details. Standard Military Drawing (SMD) parts are available for each package and lead style.

Because the same electrical die (emitters and detectors) are used for each channel of each device listed in this data sheet, absolute maximum ratings, recommended operating conditions, electrical specifications, and performance characteristics shown in the figures are similar for all parts except as noted. Additionally, the same package assembly processes and materials are used in all devices. These similarities justify the use of a common data base for die related reliability and certain limited radiation test results.

Truth Table

(Positive Logic)

Input	Output
On (H)	L
Off (L)	H

NOTE The connection of a 0.1- μ F bypass capacitor between V_{CC} and GND is recommended.

Selection Guide–Package Styles and Lead Configuration Options

Package	16-pin DIP	8-pin DIP	8-pin DIP	16-pin Flat Pack	20-Pad LCCC
Lead Style	Through Hole	Through Hole	Through Hole	Unformed Leads	Surface Mount
Channels	4	1	2	4	2
Common Channel Wiring	V_{CC} , GND	None	V_{CC} , GND	V_{CC} , GND	None
Part Number and Options					
Commercial	6N140A	HCPL-5700	HCPL-5730	HCPL-6750	HCPL-6730
MIL-PRF-38534 Class H	6N140A/883B	HCPL-5701	HCPL-5731	HCPL-6751	HCPL-6731
MIL-PRF-38534 Class K	HCPL-177K	HCPL-570K	HCPL-573K	HCPL-675K	HCPL-673K
Standard Lead Finish	Gold Plate ^a	Gold Plate ^a	Gold Plate ^a	Gold Plate ^a	Solder Pads ^b
Solder Dipped ^b	Option #200	Option #200	Option #200		
Butt Cut/Gold Plate ^a	Option #100	Option #100	Option #100		
Gull Wing/Soldered ^b	Option #300	Option #300	Option #300		
Crew Cut/Gold Plate ^a	Option #600	Option #600	Option #600		
Class H SMD Part Number					
Prescript for all below	None	5962-	5962-	None	5962-
Gold Plate ^a	8302401EC	8981001PC	8978501PC	8302401FC	
Solder Dipped ^b	8302401EA	8981001PA	8978501PA		89785022A

Package	16-pin DIP	8-pin DIP	8-pin DIP	16-pin Flat Pack	20-Pad LCCC
Butt Cut/Gold Plate ^a	8302401YC	8981001YC	8978501YC		
Butt Cut/Soldered ^b	8302401YA	8981001YA	8978501YA		
Gull Wing/Soldered ^b	8302401XA	8981001XA	8978501ZA		
Crew Cut/Gold Plate ^a	8302401ZC				
Crew Cut/Soldered ^b	8302401ZA				
Class K SMD Part Number					
Prescript for all below	5962-	5962-	5962-	5962-	5962-
Gold Plate ^a	9800201KEC	8981002KPC	8978503KPC	9800201KFC	
Solder Dipped ^b	9800201KEA	8981002KPA	8978503KPA		8978504K2A
Butt Cut/Gold Plate ^a	9800201KYC	8981002KYC	8978503KYC		
Butt Cut/Soldered ^b	9800201KYA	8981002KYA	8978503KYA		
Gull Wing/Soldered ^b	9800201KXA	8981002KXA	8978503KZA		
Crew Cut/Gold Plate ^a	9800201KZC				
Crew Cut/Soldered ^b	9800201KZA				

- a. Gold Plate lead finish: Maximum gold thickness of leads is <100 micro inches. Typical is 60 to 90 micro inches.
b. Solder lead finish: Sn63/Pb37.

Functional Diagrams

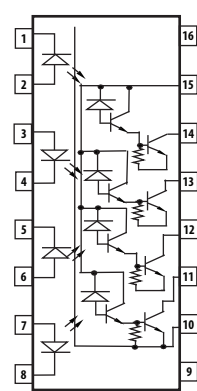
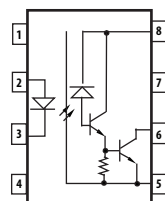
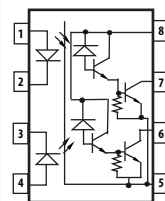
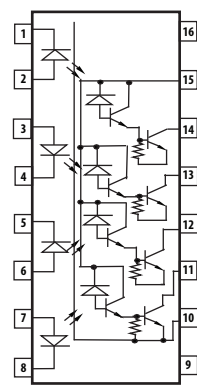
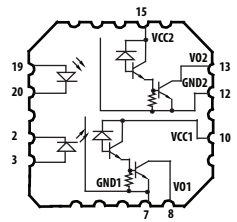
16-pin DIP	8-pin DIP	8-pin DIP	16-pin Flat Pack	20-Pad LCCC
Through Hole	Through Hole	Through Hole	Unformed Leads	Surface Mount
4 Channels	1 Channel	2 Channels	4 Channels	2 Channels
				

NOTE All DIP and flat pack devices have common V_{CC} and ground. LCCC (leadless ceramic chip carrier) package has isolated channels with separate V_{CC} and ground connections. All diagrams are top view.

Leaded Device Marking



Leadless Device Marking



Outline Drawings

16-Pin DIP Through Hole, 4 Channels



Note: Dimensions in millimeters (inches).

16-Pin Flat Pack, 4 Channels

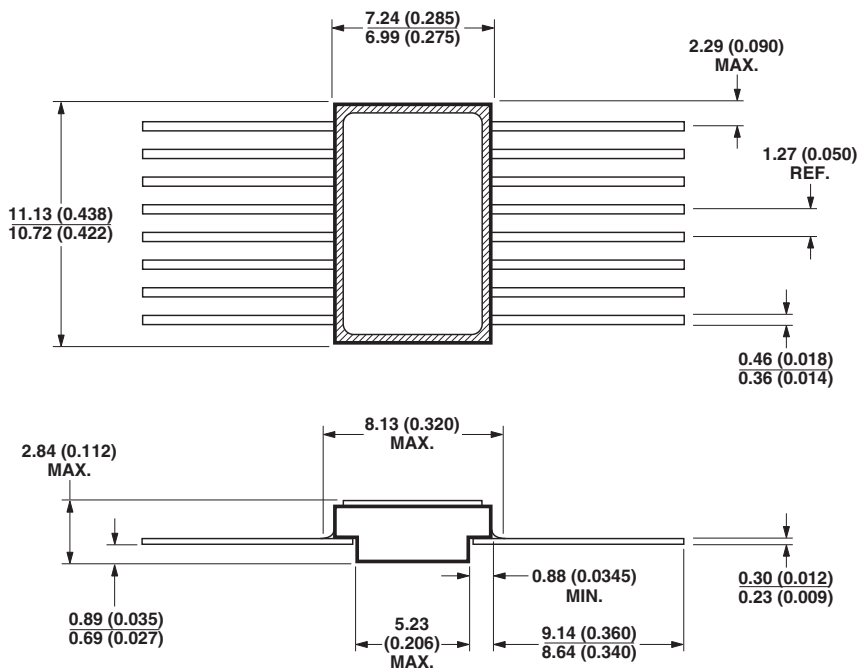

Note: Dimensions in millimeters (inches).

20-Terminal LCCC Surface Mount, 2 Channels



Note: Dimensions in millimeters (inches).
 Solder Thickness 0.127 (0.005) Max.

8-Pin DIP Through Hole, 1 and 2 Channel



Note: Dimensions in millimeters (inches).

Hermetic Optocoupler Options

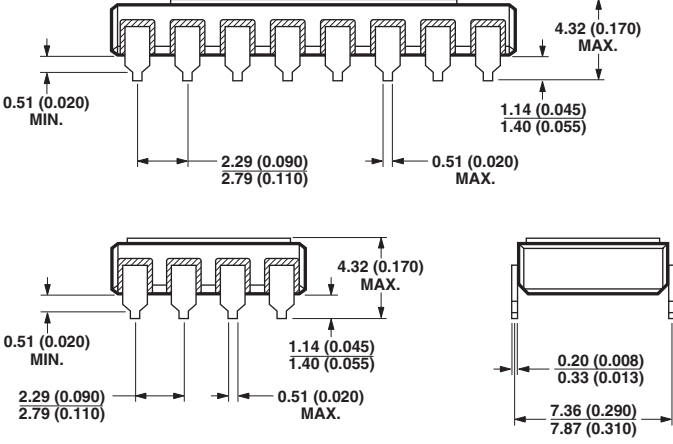
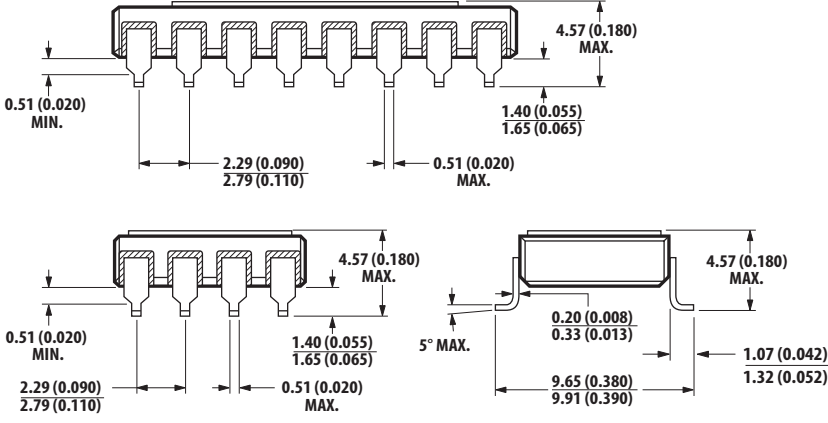
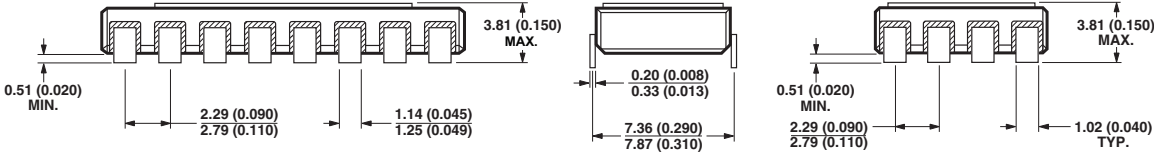
Option	Description
100	<p>Surface-mountable hermetic optocoupler with leads trimmed for butt joint assembly. This option is available on Commercial, Class H, and Class K product in 8-pin and 16-pin DIP.</p>  <p>Note: Dimensions in millimeters (inches).</p>
200	<p>Lead finish is solder dipped rather than gold plated. This option is available on Commercial, Class H, and Class K product in 8-pin and 16-pin DIP. DLA Drawing (SMD) part numbers contain provisions for lead finish. All leadless chip carrier devices are delivered with solder-dipped terminals as a standard feature.</p>
300	<p>Surface-mountable hermetic optocoupler with leads cut and bent for gull wing assembly. This option is available on Commercial, Class H, and Class K product in 8-pin and 16-pin DIP. This option has solder-dipped leads.</p>  <p>Note: Dimensions in millimeters (inches).</p>
600	<p>Surface-mountable hermetic optocoupler with leads trimmed for butt joint assembly. This option is available on Commercial, Class H, and Class K product in 8-pin and 16-pin DIP. Contact factory for the availability of this option on DLA part types.</p>  <p>Note: Dimensions in millimeters (inches).</p>

Absolute Maximum Ratings

Parameter	Symbol	Min	Max	Unit	Notes
Storage Temperature	T_S	-65	+150	°C	
Operating Temperature	T_A	-55	+125	°C	
Case Temperature	T_C	—	+170	°C	
Junction Temperature	T_J	—	+175	°C	
Lead Solder Temperature		—	260 for 10 sec	°C	
Output Current (each channel)	I_O	—	40	mA	
Output Voltage (each channel)	V_O	-0.5	20	V	a
Supply Voltage	V_{CC}	-0.5	20	V	a
Output Power Dissipation (each channel)		—	50	mW	b
Peak Input Current (each channel, <1 ms duration)		—	20	mA	
Average Input Current (each channel)	I_F	—	10	mA	c
Reverse Input Voltage (each channel)	V_R	—	5	V	
Package Power Dissipation (each channel)	P_D	—	200	mW	

- GND pin should be the most negative voltage at the detector side. Keeping V_{CC} as low as possible, but greater than 2.0V, provides the lowest total I_{OH} over temperature.
- Output power is collector output power plus total supply power for the single-channel device. For the dual-channel device, output power is collector output power plus one half the total supply power. For the quad-channel device, output power is collector output power plus one fourth of total supply power. Derate at 1.66 mW/°C above 110°C.
- Derate I_F at 0.33 mA/°C above 110°C.

8-Pin Ceramic DIP Single Channel Schematic



ESD Classification

(MIL-STD-883, Method 3015)	
HCPL-5700/01/0K and 6730/31/3K	▲▲, Class 2
6N140A, 6N140A/883B, HCPL-177K, HCPL-6750/51/5K and HCPL-5730/31/3K	●, Class 3

Recommended Operating Conditions

Parameter	Symbol	Min	Max	Unit
Input Voltage, Low Level (Each Channel)	$V_{F(OFF)}$	—	0.8	V
Input Current, High Level (Each Channel)	$I_{F(ON)}$	0.5	5	mA
Supply Voltage	V_{CC}	2.0	18	V
Output Voltage	V_O	2.0	18	V

Electrical Characteristics

T_A = -55°C to +125°C, unless otherwise specified.

Parameter	Symbol	Test Conditions	Group A ^a Subgroup	Limits			Unit	Fig	Notes	
				Min	Typ ^b	Max				
Current Transfer Ratio	CTR	I _F = 0.5 mA, V _O = 0.4V, V _{CC} = 4.5V	1, 2, 3	300	1500	—	%	3	c, d	
		I _F = 1.6 mA, V _O = 0.4V, V _{CC} = 4.5V		300	1000	—				
		I _F = 5 mA, V _O = 0.4V, V _{CC} = 4.5V		200	500	—				
Logic Low Output Voltage	V _{OL}	I _F = 0.5 mA, I _{OL} = 1.5 mA, V _{CC} = 4.5V	1, 2, 3	—	0.11	0.4	V	2	c	
		I _F = 1.6 mA, I _{OL} = 4.8 mA, V _{CC} = 4.5V		—	0.13	0.4			c, e	
		I _F = 5 mA, I _{OL} = 10 mA, V _{CC} = 4.5V		—	0.16	0.4			c	
Logic High Output Current	I _{OH}	I _F = 2 μA, V _O = 18V, V _{CC} = 18V	1, 2, 3	—	0.001	250	μA		c	
	I _{OHX}					250			μA	c, f
Logic Low Supply Current	Single Channel and LCCC	I _F = 1.6 mA, V _{CC} = 18V	1, 2, 3	—	1.0	2	mA	4	g	
	Dual Channel					I _{F1} = I _{F2} = 1.6 mA, V _{CC} = 18V			4	
	Quad Channel					I _{F1} = I _{F2} = I _{F3} = I _{F4} = 1.6 mA, V _{CC} = 18V			4	
Logic High Supply Current	Single Channel and LCCC	I _F = 0 mA, V _{CC} = 18V	1, 2, 3	—	0.001	20	μA		g	
	Dual Channel					I _{F1} = I _{F2} = 0 mA, V _{CC} = 18V			40	
	Quad Channel					I _{F1} = I _{F2} = I _{F3} = I _{F4} = 0 mA, V _{CC} = 18V			40	
Input Forward Voltage	Single and Dual Channel	I _F = 1.6 mA	1, 2, 3	1	1.0	1.4	V	1	c	
				2	—	—				1.7
				3	—	—				1.8
	1, 2, 3			1.0	1.4	1.8				
	LCCC			1, 2	—	1.4				1.7
	Quad Channel				3	—				—
Input Reverse Breakdown Voltage	B _{VR}	I _R = 10 μA	1, 2, 3	5	—	—	V		c	
Input-Output Insulation Leakage Current	I _{I-O}	≤65% Relative Humidity T _A = 25°C, t = 5s, V _{I-O} = 1500 VDC	1	—	—	1.0	μA		h, i	

Parameter	Symbol	Test Conditions	Group A ^a Subgroup	Limits			Unit	Fig	Notes	
				Min	Typ ^b	Max				
Capacitance Between Input-Output	C_{I-O}	$f = 1 \text{ MHz}, T_A = 25^\circ\text{C}$	4	—	—	4	pF		c, j k, l	
Propagation Delay Time to Logic Low at Output	t_{PHL}	$I_F = 0.5 \text{ mA}, R_L = 4.7 \text{ k}\Omega, V_{CC} = 5\text{V}$	9, 10, 11	—	30	100	μs	5, 6, 7, 8	c	
		$I_F = 1.6 \text{ mA}, R_L = 1.5 \text{ k}\Omega, V_{CC} = 5\text{V}$	9, 10, 11	—	5	30			c, e	
		$I_F = 5 \text{ mA}, R_L = 680\Omega, V_{CC} = 5\text{V}$	9	—	2	5			10	c, l
			10, 11							10
9, 10, 11	10		c, e							
Propagation Delay Time to Logic High at Output	t_{PLH}	$I_F = 0.5 \text{ mA}, R_L = 4.7 \text{ k}\Omega, V_{CC} = 5\text{V}$	9, 10, 11	—	17	60	μs	5, 6, 7, 8	c	
		$I_F = 1.6 \text{ mA}, R_L = 1.5 \text{ k}\Omega, V_{CC} = 5\text{V}$	9, 10, 11	—	14	50			c, e	
		$I_F = 5 \text{ mA}, R_L = 680\Omega, V_{CC} = 5\text{V}$	9	—	8	20			30	c, l
			10, 11							30
9, 10, 11	30		c, e							
Common Mode Transient Immunity at Low Output Level	$ CM_L $	$V_{CC} = 5\text{V}, I_F = 1.6 \text{ mA}$ $R_L = 1.5 \text{ k}\Omega, V_{CM} = 25 V_{P-P}^l$ $ V_{CM} = 50 V_{P-P}^e$	9, 10, 11	500	1000		$\text{V}/\mu\text{s}$	9	c, m, n, o	
Common Mode Transient Immunity at High Output Level	$ CM_H $	$V_{CC} = 5\text{V}, I_F = 0 \text{ mA}$ $R_L = 1.5 \text{ k}\Omega, V_{CM} = 25 V_{P-P}^l$ $ V_{CM} = 50 V_{P-P}^e$	9, 10, 11	500	1000		$\text{V}/\mu\text{s}$	9	c, m, n, o	

- Commercial parts receive 100% testing at 25°C (Subgroups 1 and 9). SMD, Class H and Class K parts receive 100% testing at 25, 125, and -55°C (Subgroups 1 and 9, 2 and 10, 3 and 11, respectively).
- All typical values are at $V_{CC} = 5\text{V}, T_A = 25^\circ\text{C}$.
- Each channel.
- Current Transfer Ratio is defined as the ratio of output collector current, I_O , to the forward LED input current, I_F , times 100%.
- Not required for 6N140A, 6N140A/883B, HCPL-177K, HCPL-6750/51/5K, 8302401, and 5962-9800201 types.
- I_{OHX} is the leakage current resulting from channel-to-channel optical crosstalk. $I_F = 2 \mu\text{A}$ for channel under test. For all other channels, $I_F = 10 \text{ mA}$.
- The HCPL-6730, HCPL-6731, and HCPL-673K dual-channel parts function as two independent single channel units. Use the single channel parameter limits.
- All devices are considered two-terminal devices; measured between all input leads or terminals shorted together and all output leads or terminals shorted together.
- This is a momentary withstand test, not an operating condition.
- Measured between each input pair shorted together and all output connections for that channel shorted together.
- Parameters tested as part of device initial characterization and after design and process changes. Parameters guaranteed to limits specified for all lots not specifically tested.
- Required for 6N140A, 6N140A/883B, HCPL-177K, HCPL-6750/51/5K, 8302401, and 5962-9800201 types.
- CM_L is the maximum rate of rise of the common mode voltage that can be sustained with the output voltage in the logic low state ($V_O < 0.8 \text{ V}$). CM_H is the maximum rate of fall of the common mode voltage that can be sustained with the output voltage in the logic high state ($V_O > 2.0 \text{ V}$).

- n. In applications where dV/dt may exceed $50,000 \text{ V}/\mu\text{s}$ (such as a static discharge), a series resistor, R_{CC} , should be included to protect the detector ICs from destructively high surge currents. The recommended value is:
For single channel:

$$R_{CC} = \frac{1 \text{ (V)}}{0.15 I_F \text{ (mA)}} \text{ k}\Omega$$

For dual channel:

$$R_{CC} = \frac{1 \text{ (V)}}{0.3 I_F \text{ (mA)}} \text{ k}\Omega$$

For quad channel:

$$R_{CC} = \frac{1 \text{ (V)}}{0.6 I_F \text{ (mA)}} \text{ k}\Omega$$

- o. Parameters tested as part of device initial characterization and after design and process changes. Parameters guaranteed to limits specified for all lots not specifically tested.

Typical Characteristics

$T_A = 25^\circ\text{C}$, $V_{CC} = 5\text{V}$.

Parameter	Symbol	Typ	Unit	Test Conditions	Note
Input Capacitance	C_{IN}	60	pF	$V_F = 0\text{V}$, $f = 1 \text{ MHz}$	a
Input Diode Temperature Coefficient	$\Delta V_F / \Delta T_A$	-1.8	mV/°C	$I_F = 1.6 \text{ mA}$	a
Resistance (Input-Output)	R_{I-O}	10^{12}	Ω	$V_{I-O} = 500\text{V}$	a, b
Capacitance (Input-Output)	C_{I-O}	2.0	pF	$f = 1 \text{ MHz}$	a, b
Dual and Quad Channel Product Only					
Input-Input Leakage Current	I_{I-I}	0.5	nA	Relative Humidity = $\leq 65\%$, $V_{I-I} = 500\text{V}$, $t = 5\text{s}$	c
Resistance (Input-Input)	R_{I-I}	10^{12}	Ω	$V_{I-I} = 500\text{V}$	c
Capacitance (Input-Input)	C_{I-I}	1.0	pF	$f = 1 \text{ MHz}$	c

- a. Each channel.
b. Measured between each input pair shorted together and all output connections for that channel shorted together.
c. Measured between adjacent input pairs shorted together for each multichannel device.

Figure 1 Input Diode Forward Current vs. Forward Voltage



Figure 2 Normalized DC Transfer Characteristics



Figure 3 Normalized Current Transfer Ratio vs. Input Diode Forward Current



Figure 4 Normalized Supply Current vs. Input Diode Forward Current



Figure 5 Propagation Delay to Logic Low vs. Input Pulse Period



Figure 6 Propagation Delay vs. Temperature



Figure 7 Propagation Delay vs. Input Diode Forward Current



Figure 8 Switching Test Circuit



* See note n on page 10.

** C₁ includes probe and stray wiring capacitance.



Figure 9 Test Circuit for Transient Immunity and Typical Waveforms



* See note n on page 10.

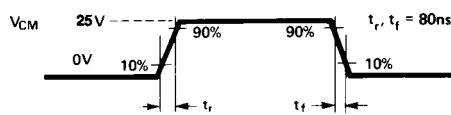

Figure 10 Recommended Drive Circuitry Using TTL Open-Collector Logic

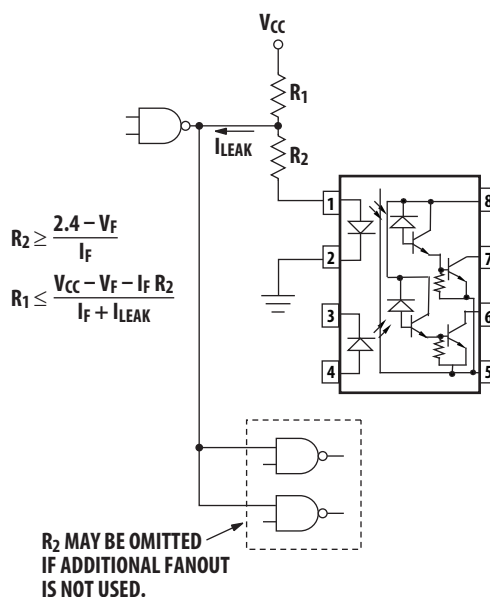
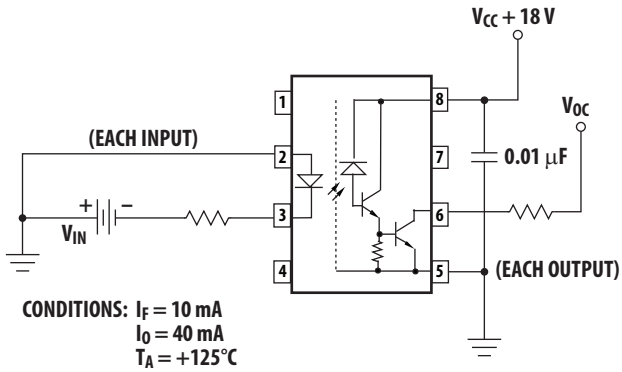

Figure 11 Operating Circuit for Burn-In and Steady State Life Tests



* ALL CHANNELS TESTED SIMULTANEOUSLY.