

SIGNAL BROADCASTER

ELECTRONIC MODULES

Introduction

The BROADCASTER accepts standard incremental encoder inputs, (two channels in quadrature plus an index and complements) and can broadcast up to four encoder signals to four independent devices. Each of the broadcast signals is optically isolated eliminating ground loops. This compact package also allows for signal processing options, such as anti-dither filter, integer countdown or pulse and direction outputs, to be incorporated into each of the four broadcast signals independently. The broadcaster is ideal for driving multiple receivers from a single encoder in applications like electronic line shafting or synchronization of multiple devices to a single operation.

The module accepts signals of 5, 12-15 and 24 VDC and provides three output options: $V_{out} = V_{in}$, $V_{out} = 5V$ or NPN open collector. The compact package mounts to standard EN 50 022 35mm X 7.5mm DIN rail and is 142mm wide, 78mm deep and 45mm above the DIN rail. A 155mm section of DIN rail is included.

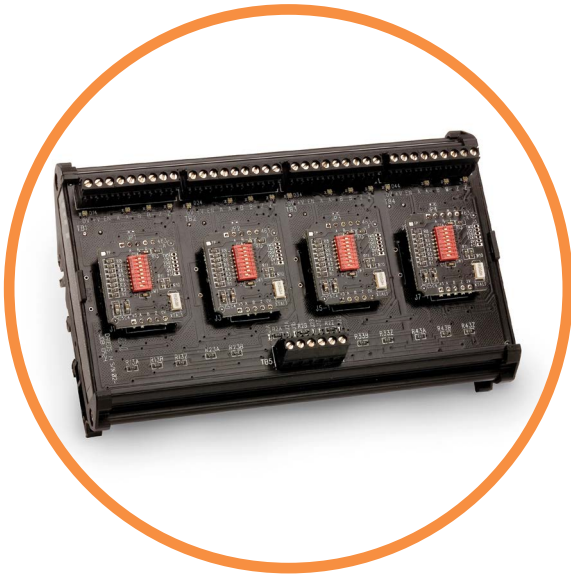

Features

- Broadcasts signals from a single encoder to four independent receivers
- Signal processing modules (pulse converter, integer countdown, anti-dither) can be added to each output for additional capabilities
- Accepts all standard input voltages and types: single ended, differential and open collector
- Signals are optically isolated for high noise immunity
- Compact package saves installation costs

SPECIFICATIONS

(For Isolated Circuit And Anti-Dither Functions)

Differential Line Driver (See Figure 1)

The Encoder signals from 5 VDC to 24 VDC (must specify the voltage when ordering)

This is the preferred type of encoder output as it has the best noise immunity. Connect each encoder signal to its like input (A to A, A/ to A/, etc).

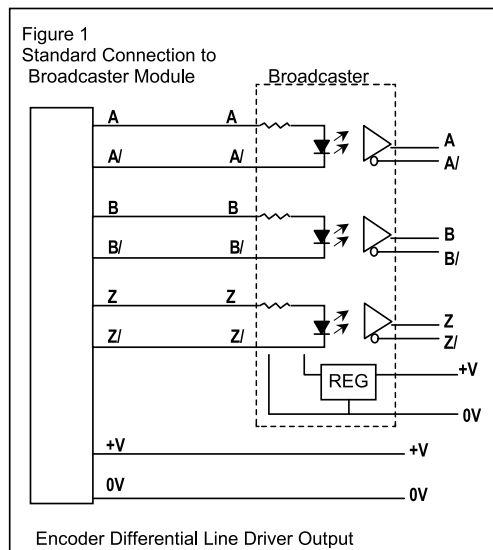

Single Ended Line Driver (See Figure 2)

Encoder signal from 5 VDC to 24 VDC (must specify the voltage when ordering)

Connect broadcaster A to optical isolator module input channel A, B to B and Z to Z. Connect the A/, B/, and Z/ inputs of the optical isolator to circuit common of the encoder supply. Single ended operation is limited to shorter cable runs and is more susceptible to noise.

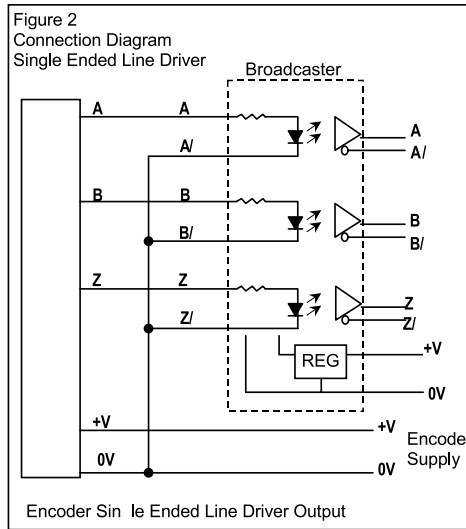

Open Collector with or without Internal Pull-up Resistors (See Figure 3)

Encoder NPN (sinking) outputs.

Connect encoder output A to optical isolator module input A/, B to B/ and Z to Z/. Connect the A, B, and Z inputs of the broadcaster to the positive encoder supply line. This connection results in a logic inversion within the broadcaster module. To compensate for the logic reversal, swap A for A/, B for B/, and Z for Z/ at the broadcaster outputs.

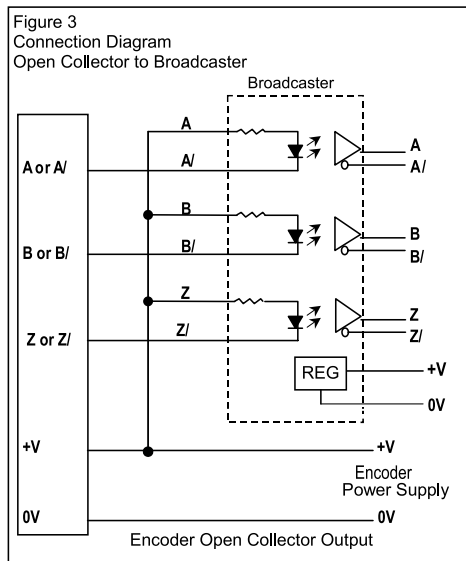

TERMINATION PINOUTS

Encoder Side		
PIN	Description	Notes
A, A/	Channel A Inputs	Input levels consistent with specified value in model number (5 V, 15 V, 24 V). Signal input current 25 mA nom. See BEI Optical Isolator Module Applications Guide for single ended and open collector connection diagrams.
B, B/	Channel B Inputs	
Z, Z/	Channel Z Inputs	
T1, T2, T3	Uncommitted Terminals	Non-committed terminals. Provided for use as connection points for encoder power.

Driver Side		
PIN	Description	Notes
+ V	Power supply 5 – 28 VDC 125 mA + load current typ.	Supply lines between driver sections are not connected. Driver must be powered in order to produce an output. Supply voltage need not be the same for different driver sections.
0 V	Power supply common	
EN	Output Enable	HI = Output Active, LO = High Impedance Internal pull-up to V+
A, A/	Channel A Outputs	Output levels consistent with driver type and supply voltage (V/V outputs).
B, B/	Channel B Outputs	
Z, Z/	Channel Z Outputs	



BROADCASTER BLOCK DIAGRAM

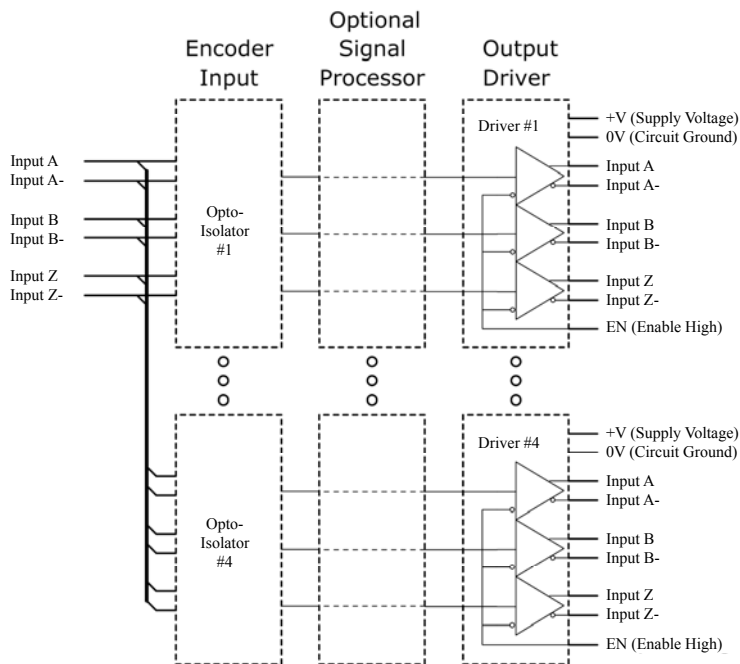



ORDERING OPTIONS

Example : BX-5-IC/V-IC/V-P2/5-P2/5

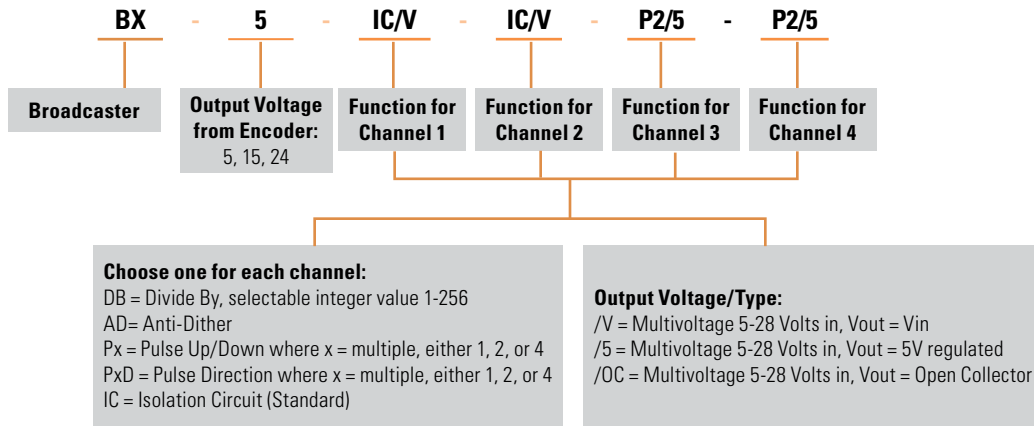

ADDITIONAL MODULES AND ACCESSORIES

Power Supply

With a wide range of acceptable input voltages (AC and DC) this DIN Rail mountable power supply is usable in virtually all industrial applications worldwide. It has built in surge protection to reduce faults due to transients and it has 100% reserve capacity for startup and overload conditions.



Cable And Cable Assemblies

Cable reels for your own custom wiring requirements or cable assemblies are available, using high quality custom BEI standard cable consisting of four, low capacitance shielded twisted pairs with an overall shield, extra large conductors for power, and signal ground; all within an abrasion-resistant PVC jacket.



Cable Reels

100 ft. reel	Part No. 37048-003-100
500 ft. reel	Part No. 37048-003-500

Cable Assemblies

Part Nos. for MS3106F14S-6S Mating Connector
10 ft. # 31186-1410 | 20 ft. # 31186-1420 | 30ft. # 31186-1430

Part Nos. for MS3106F16S-1S Mating Connector
10 ft. # 31186-1610 | 20 ft. # 31186-1620 | 30ft. # 31186-1630

Part Nos. for MS3106F18S-1S Mating Connector
10 ft. # 31186-1810 | 20 ft. # 31186-1820 | 30ft. # 31186-1830

