

DO NOT SCALE
D NP

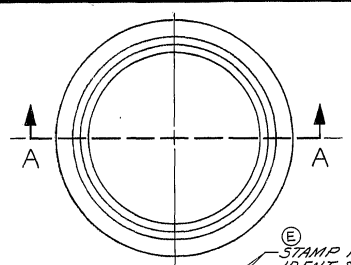

6288947

- Z₁ ORIGINAL ELONGATION 200% MINIMUM.
- Z₂ OZONE TEST. SAMPLES SHALL BE PREPARED IN ACCORDANCE WITH ASTM D518, METHOD B, AND TESTED IN ACCORDANCE WITH ASTM D-1149 AT 40°C WITH AN OZONE CONCENTRATION OF 50 PPHM.
- Z₃ BRITTLE POINT ASTM D746 -35°F MAXIMUM.
- Z₄ PART SHALL BE NON-BLOOMING.
- Z₅ COLOR - BLACK.
- Z₆ DUROMETER 65±5.
- Z₇ COMPRESSION SET, ASTM D-395 SOLID, 22 HR. AT 158°F, 20% MAX.

DATE	SYM	REVISION RECORD	C/N NO.
2-12-68	C	REVISED & REORANED	3034
5-2-68	D	MATL. SPEC. REVISED	31223
	D	O50 R-OPTIONAL - REMOVED	
2-20-69	E	MATL. SPEC. REV.	34276
	E	25° WAS 15°	
	E	NOTES ADDED	
2-11-71	∞	STAMPING NOTE REVISED	42045
3-15-74	-	VENDOR NOTE ADDED	52128 BY
3-5-76	-	VENDOR NOTE REVISED	53108 BY
18MY82	-	NOTE #2 ADDED	81059 JH

PACKARD ELECTRIC DIVISION
GENERAL MOTORS CORPORATION
WARREN, OHIO

MAX. FLASH PERMISSIBLE .020, EXCEPT AS NOTED BELOW.
NO FLASH IN THIS AREA.

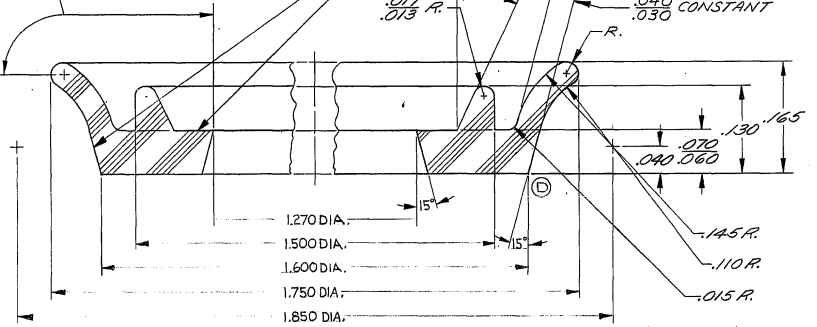

ROUTING
165
168-A
63-A
74-A

SECTION A-A
SCALE 10:1

NOTE: 1. VENDOR GUARANTEES SHELF LIFE OF MATERIAL TO BE FOUR (4) MONTHS. (DATE OF MANUFACTURE AND "USE BEFORE" DATE TO APPEAR ON CONTAINERS).
2. GASKETS SHALL BE STACKED BY VENDOR IN SHIPPING CONTAINER TO KEEP GASKETS FLAT AND ROUND TO FACILITATE AUTOMATIC FEEDING.

CODE NO. 6901

TOLERANCE UNLESS OTHERWISE SPECIFIED
DECIMAL ± .010
FRACTIONAL ±
ANGULAR ± 2°

DWG. DATE 10-18-66 SCALE 2:1 DR. T. MUDREY

APPR. [Signature]

REFERENCE: C02D3727

MATERIAL SPEC. WAS EX-5057P
ASTM D-3000, SAE J-2000
20CT15, A14, E14, E34
21, 22, 23, 24, 25, 26, 27

NAME: GASKET-LAMP SOCKET

PART NO. 6288947

SIZE B