

- ### Features
- Essentially infinite resolution
  - Excellent rotational life
  - High quality, rugged construction
  - General purpose applications
  - Non-standard features available
  - Cost and space saving

**BOURNS®**

## 6539/6639 - Precision Potentiometer

Electrical Characteristics <sup>1</sup>	6539 Servo Mount	6639 Bushing Mount
Standard Resistance Range.....	1 K to 100 K ohms.....	1 K to 100 K ohms
Total Resistance Tolerance.....	±15 %.....	±15 %
Independent Linearity.....	±2.0 %.....	±2.0 %
Effective Electrical Angle.....	340 ° +3 °.....	340 ° +3 °
End Voltage.....	0.5 % maximum.....	0.5 % maximum
Output Smoothness.....	0.1 %.....	0.1 %
Dielectric Withstanding Voltage (MIL-STD-202, Method 301)		
Sea Level.....	750 VAC minimum.....	750 VAC minimum
Power Rating (Voltage Limited By Power Dissipation or 300 VAC, Whichever is Less)		
+70 °C.....	1.0 watt.....	1.0 watt
+125 °C.....	0 watt.....	0 watt
Insulation Resistance (500 VDC).....	500 megohms minimum.....	500 megohms minimum
Resolution.....	Essentially infinite.....	Essentially infinite

Environmental Characteristics <sup>1</sup>		
Operating Temperature Range.....	+1 °C to +125 °C.....	-40 °C to +125 °C
Storage Temperature Range.....	-65 °C to +125 °C.....	-65 °C to +125 °C
Temperature Coefficient		
Over Storage Temperature Range.....	±500 ppm/°C maximum.....	±500 ppm/°C maximum
Vibration.....	15 G.....	15 G
Wiper Bounce.....	0.1 millisecond maximum.....	0.1 millisecond maximum
Total Resistance Shift.....	±10 %.....	±10 %
Voltage Ratio Shift.....	±0.5 %.....	±0.5 %
Shock.....	50 G.....	50 G
Wiper Bounce.....	0.1 millisecond maximum.....	0.1 millisecond maximum
Total Resistance Shift.....	±5 %.....	±5 %
Voltage Ratio Shift.....	±0.5 %.....	±0.5 %
Load Life.....	1,000 hours, 1 watt.....	1,000 hours, 1 watt
Total Resistance Shift.....	±10 %.....	±10 %
Rotational Life (No Load).....	10,000,000 shaft revolutions.....	10,000,000 shaft revolutions
Total Resistance Shift.....	±10 % maximum.....	±10 % maximum
Moisture Resistance (MIL-STD-202, Method 106)		
Total Resistance Shift.....	±15 %.....	±15 %
IP Rating.....	IP 40.....	IP 40

Mechanical Characteristics <sup>1</sup>		
Mechanical Angle.....	Continuous, Stops (340 ° +8 °, -0 °) available	
Stop Strength (applies to -301 with mechanical stops only).....	22.6 N-cm (2 lb.-in.)	
Torque (Starting & Running) <sup>2</sup> .....	0.40 N-cm (0.5 oz.-in.) max.	
Mounting.....	170-200 N-cm (15-18 lb.-in.) maximum	
Shaft Runout.....	0.13 mm (0.005 in.) T.I.R.	
Lateral Runout.....	0.08 mm (0.003 in.) T.I.R.	
Shaft End Play.....	0.13 mm (0.005 in.) T.I.R.	
Shaft Radial Play.....	0.13 mm (0.005 in.) T.I.R.	
Pilot Diameter Runout.....	0.06 mm (0.0025 in.) T.I.R.	
Backlash.....	0.1 ° maximum	
Weight.....	18 gm (6539 Servo Mount), 24 gm (6639 Bushing Mount)	
Terminals.....	Rear Turret Type	
Soldering Condition		
Manual Soldering.....	96.5Sn/3.0Ag/0.5Cu solid wire or no-clean rosin cored wire 370 °C (700 °F) max. for 3 seconds	
Wave Soldering.....	96.5Sn/3.0Ag/0.5Cu solder with no-clean flux 260 °C (500 °F) max. for 5 seconds	
Wash processes.....	Not recommended	
Marking.....	Manufacturer's name and part number, resistance value and tolerance, linearity tolerance, wiring diagram, and date code.	
Ganging (Multiple Section Pots).....	1 cup maximum	
Hardware (6639 only).....	One lockwasher (H-37-2) and one mounting nut (H-38-2) is shipped with potentiometer.	

<sup>1</sup>At room ambient: +25 °C nominal and 50 % relative humidity nominal, except as noted.  
<sup>2</sup>2.82 N-cm (4.0 oz.-in.) max. at -40 °C.



**WARNING Cancer and Reproductive Harm - [www.P65Warnings.ca.gov](http://www.P65Warnings.ca.gov)**

\*RoHS Directive 2015/863, Mar 31, 2015 and Annex.  
 Specifications are subject to change without notice.  
 Users should verify actual device performance in their specific applications.  
 The products described herein and this document are subject to specific legal disclaimers as set forth on the last page of this document, and at [www.bourns.com/docs/legal/disclaimer.pdf](http://www.bourns.com/docs/legal/disclaimer.pdf).

### Product Dimensions

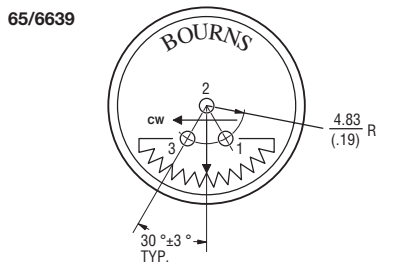
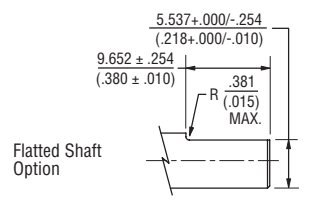
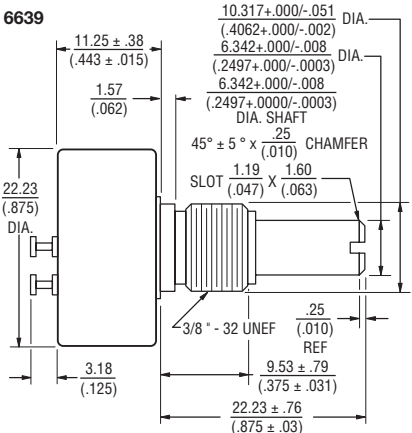
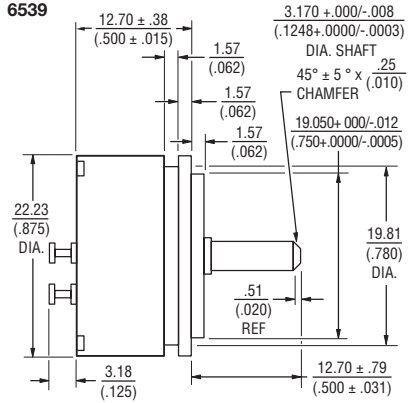

TOLERANCES: EXCEPT WHERE NOTED  
 DECIMALS: .XX ± .51 XXX ± .13  
 FRACTIONS: ±1/64  
 DIMENSIONS: MM (IN.)

# 6539/6639 - Precision Potentiometer



## Recommended Part Numbers

Part Number	Resistance (Ω)
<b>6539S-1-102</b>	<b>1,000</b>
<b>6539S-1-502</b>	<b>5,000</b>
<b>6539S-1-103</b>	<b>10,000</b>

**BOLDFACE** LISTINGS ARE IN STOCK AND READILY AVAILABLE THROUGH DISTRIBUTION. FOR OTHER OPTIONS CONSULT FACTORY.

Part Number	Mechanical Stop	A/R Lug	Shaft
<b>6639S-1-RC</b>	No	No	Slotted
<b>6639S-2-RC</b>	No	No	Flatted
<b>6639S-3-RC</b>	No	Yes	Slotted
<b>6639S-4-RC</b>	No	Yes	Flatted
<b>6639S-5-RC</b>	Yes	Yes	Slotted
<b>6639S-6-RC</b>	Yes	Yes	Flatted
<b>6639S-7-RC</b>	Yes	No	Slotted
<b>6639S-8-RC</b>	Yes	No	Flatted

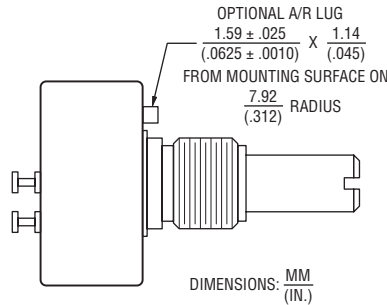

## Standard Resistance Table

Resistance (Ohms)	Resistance Code
1,000	102
2,000	202
5,000	502
10,000	103
20,000	203
50,000	503
100,000	104

## Schematic

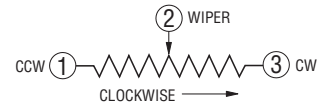

## Panel Thickness Dimensions

(For Bushing Mount Only)

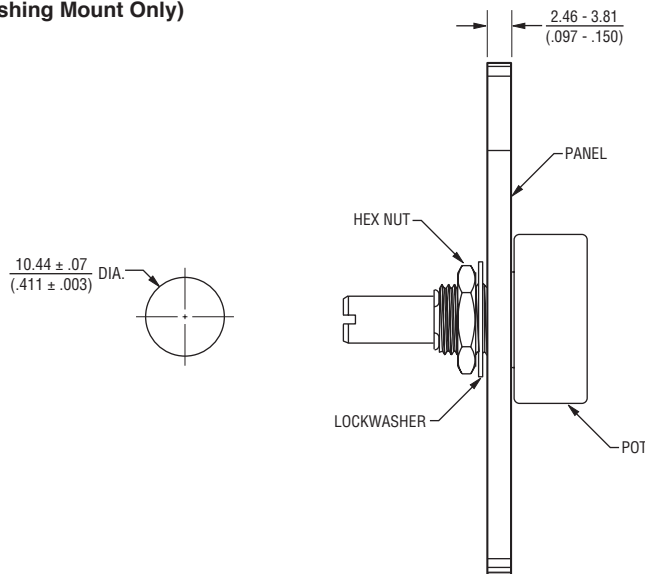

Panel thickness and hole diameters are recommended for best fit. However, customers may adjust the dimensions to suit their specific application.

DIMENSIONS:  $\frac{\text{MM}}{\text{(INCHES)}}$  TOLERANCES:  $\pm \frac{0.127}{(.005)}$

REV. 06/20

Specifications are subject to change without notice.

Users should verify actual device performance in their specific applications.

The products described herein and this document are subject to specific legal disclaimers as set forth on the last page of this document, and at [www.bourns.com/docs/legal/disclaimer.pdf](http://www.bourns.com/docs/legal/disclaimer.pdf).