

8 PIN DIP LOW INPUT CURRENT HIGH GAIN SPLIT DARLINGTON PHOTOCOUPLER 6N138 6N139

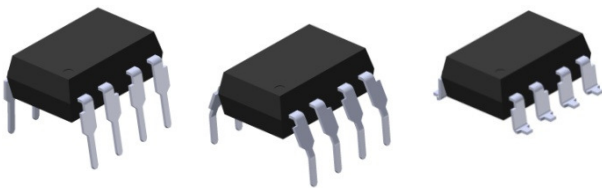

Features

- High current transfer ratio—2000% typical
- High isolation voltage between input and output (Viso=5000 Vrms)
- Guaranteed performance from 0°C to 70 °C
- Pb free and RoHS compliant.
- UL approved (No. 214129)
- VDE approved (No. 132249)
- SEMKO approved
- NEMKO approved
- DEMKO approved
- FIMKO approved
- CSA approved (No. 2037145)

Schematic

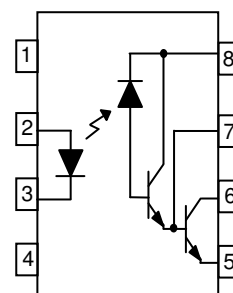

Pin Configuration

1. No Connection
2. Anode
3. Cathode
4. No Connection
5. Gnd
6. Vout
7. V_B
8. Vcc

Description

The 6N138 and 6N139 devices each consists of an infrared emitting diode, optically coupled to a high gain split Darlington photo detector. They provide extremely high current transfer ratio between input and output, with access to a base terminal to adjust the gain bandwidth. These devices are packaged in an 8-pin DIP package and available in wide-lead spacing and SMD options.

Applications

- Digital logic ground isolation
- RS-232C line receiver
- Low input current line receiver
- Microprocessor bus isolation
- Current loop receiver

Absolute Maximum Ratings (Ta=25°C)

	Parameter	Symbol	Rating	Unit
Input	Forward current	I_F	20	mA
	Peak forward current (50% duty, 1ms P.W)	I_{FP}	40	mA
	Peak transient current ($\leq 1\mu s$ P.W,300pps)	I_{Ftrans}	1	A
	Reverse voltage	V_R	5	V
	Power dissipation	P_{IN}	45	mW
Output	Power dissipation	P_O	100	mW
	Output current	I_O	60	mA
	Emitter-Base Reverse Voltage	V_{ER}	0.5	V
	Output voltage	V_O	-0.5 to 7 -0.5 to 18	V
	Supply voltage	V_{CC}	-0.5 to 7 -0.5 to 18	V
	Isolation voltage ^{*1}	V_{ISO}	5000	V rms
Operating temperature	T_{OPR}	-40 ~ +85	°C	
Storage Temperature	T_{STG}	-55 ~ +125	°C	
Soldering temperature ^{*2}	T_{SOL}	260	°C	

Notes:

*1 AC for 1 minute, R.H.= 40 ~ 60% R.H. In this test, pins 1, 2, 3, 4 are shorted together, and pins 5, 6, 7, 8 are shorted together.

*2 For 10 seconds

Electrical Characteristics (T_A=0 to 70°C unless specified otherwise)

Input

Parameter	Symbol	Min.	Typ.	Max.	Unit	Condition
Forward voltage	V _F	-	1.3	1.7	V	I _F = 1.6mA
Reverse Voltage	V _R	5.0	-	-	V	I _R = 10μA, T _A =25°C
Temperature coefficient of forward voltage	ΔV _F /ΔT _A	-	-1.8	-	mV/°C	I _F =1.6mA

Output

Parameter	Symbol	Min	Typ.	Max.	Unit	Condition
Logic High Output Current	<u>6N138</u> 6N139	I _{OH}	-	0.01	100	μA I _F =0mA, V _O =V _{CC} =18V
			-	-	250	
Logic Low Supply Current	<u>6N138</u> 6N139	I _{CCL}	-	0.6	1.5	mA I _F =1.6mA, V _O =Open, V _{CC} =18V
			-	0.05	10	
Logic High Supply Current	<u>6N138</u> 6N139	I _{CCH}	-	0.05	10	μA I _F =0mA, V _O =Open, V _{CC} =18V

Transfer Characteristics (T_a=0 to 70°C unless specified otherwise, V_{CC}=4.5V)

Parameter	Symbol	Min	Typ.	Max.	Unit	Condition	
Current Transfer Ratio	<u>6N139</u> 6N138	CTR	400	2500	-	%	I _F = 0.5mA, V _O = 0.4V, V _{CC} =4.5V
			500	2000	-		I _F = 1.6mA, V _O = 0.4V, V _{CC} =4.5V
			300	2000	-		I _F = 1.6mA, V _O = 0.4V, V _{CC} =4.5V
Logic Low Output Voltage	<u>6N139</u> 6N138	V _{OL}	-	0.05	0.4	V	I _F = 0.5mA, I _O = 2mA, V _{CC} =4.5V
			-	0.09	0.4		I _F = 1.6mA, I _O = 8mA, V _{CC} =4.5V
			-	0.12	0.4		I _F = 5mA, I _O = 15mA, V _{CC} =4.5V
			-	0.17	0.4		I _F = 12mA, I _O = 24mA, V _{CC} =4.5V
			-	0.06	0.4		I _F = 1.6mA, I _O = 4.8mA, V _{CC} =4.5V

Switching Characteristics (T_a=0 to 70°C unless specified otherwise, V_{cc}=5V)

Parameter	Symbol	Min	Typ.	Max.	Unit	Condition
Propagation Delay Time to Logic Low (Fig. 13)	6N139 TPHL	-	5	25	μs	I _F = 0.5mA, R _L =4.7kΩ, T _A =25°C
		-	-	30		I _F = 0.5mA, R _L =4.7kΩ
		-	0.2	1		I _F = 12mA, R _L =270Ω, T _A =25°C
		-	-	2		I _F = 12mA, R _L =270Ω
		-	1.4	10		I _F = 1.6mA, R _L =2.2kΩ, T _A =25°C
		-	-	15		I _F = 1.6mA, R _L =2.2kΩ
Propagation Delay Time to Logic High (Fig. 13)	6N139 TPLH	-	16	60	μs	I _F = 0.5mA, R _L =4.7kΩ, T _A =25°C
		-	-	90		I _F = 0.5mA, R _L =4.7kΩ
		-	1.7	7		I _F = 12mA, R _L =270Ω, T _A =25°C
		-	-	10		I _F = 12mA, R _L =270Ω
		-	8	35		I _F = 1.6mA, R _L =2.2kΩ, T _A =25°C
		-	-	50		I _F = 1.6mA, R _L =2.2kΩ
Common Mode Transient Immunity at Logic High (Fig. 14) ^{*3}	CM _H	1,000	-	-	V/μs	I _F = 0mA, V _{CM} =10Vp-p, R _L =2.2KΩ, T _A =25°C
Common Mode Transient Immunity at Logic Low (Fig. 14) ^{*3}	CM _L	1,000	-	-	V/μs	I _F = 1.6mA, V _{CM} =10Vp-p, R _L =2.2KΩ, T _A =25°C

* Typical values at T_a = 25°C

Typical Electro-Optical Characteristics Curves

Fig.1 LED Forward Current vs. Forward Voltage

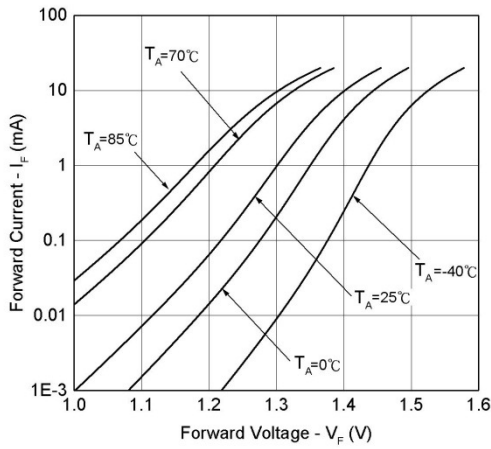

Fig.2 LED Forward Voltage vs. Temperature

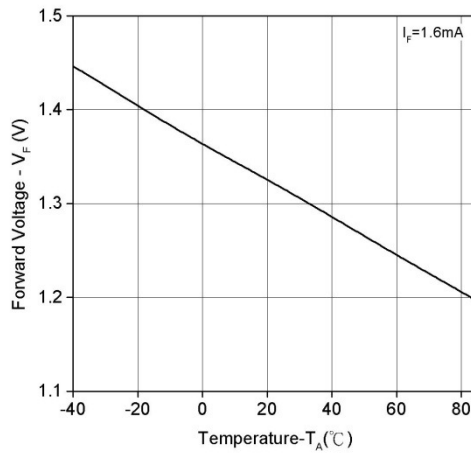

Fig.3 Output Current vs. Output Voltage

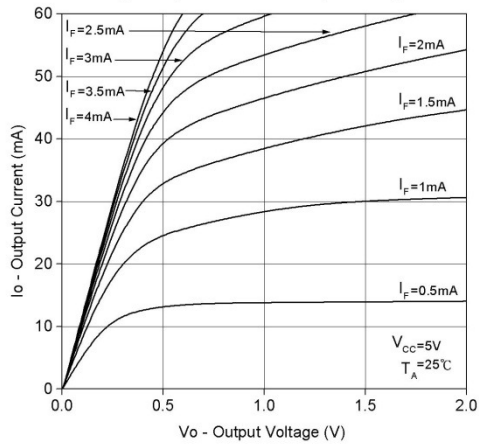

Fig.4 Output Current vs. Input Diode Forward Current

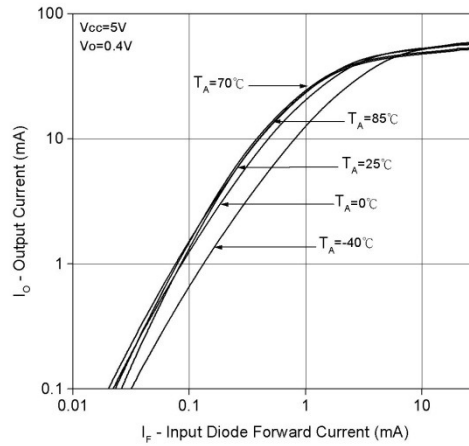

Fig.5 Current Transfer Ratio vs. Forward Current

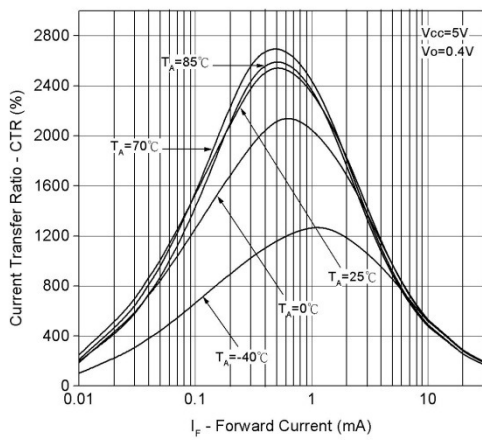

Fig.6 Current Transfer Ratio vs. Base-Emitter Resistance

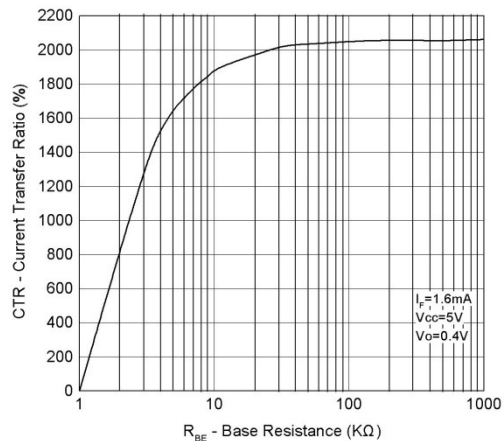

Fig.7 Non-saturated Rise and Fall Times vs. Load Resistance

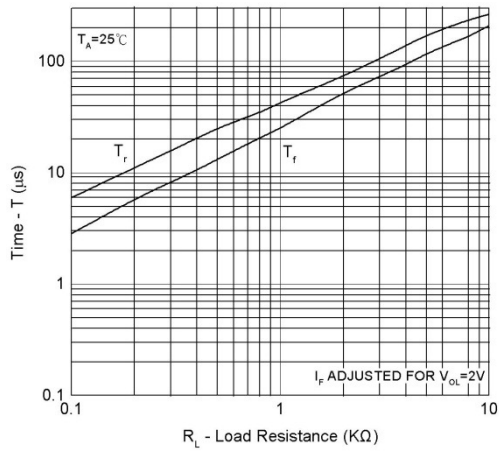

Fig.8 Propagation Delay To Logic Low vs. Base-Emitter Resistance

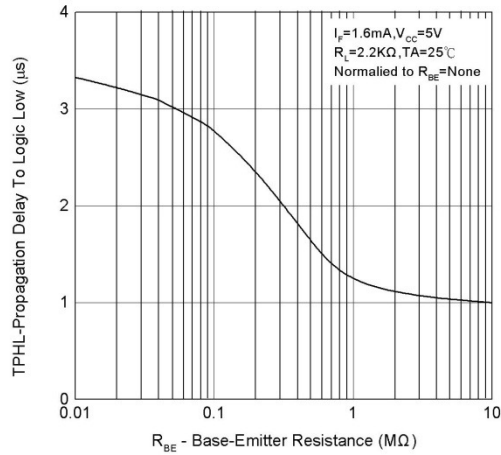

Fig.9 Propagation Delay vs. Input Diode Forward Current

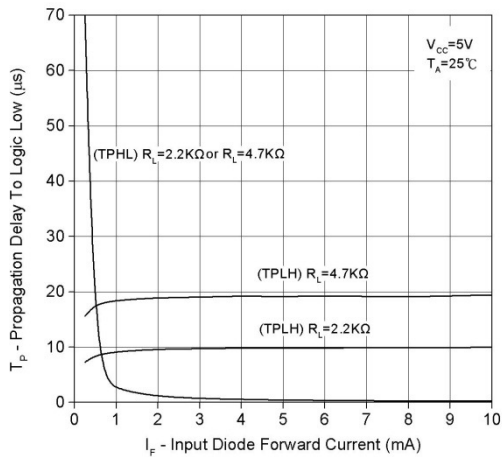

Fig.10 Propagation Delay to Logic Low vs. Pulse Period

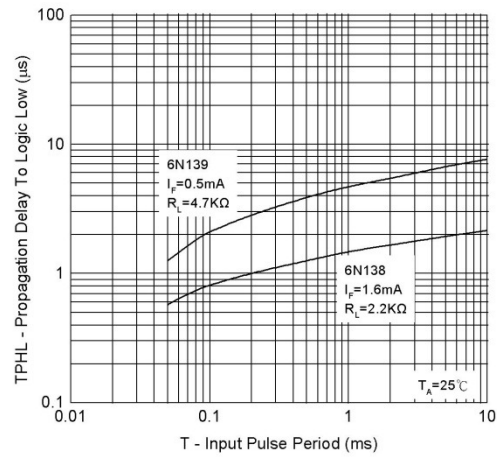

Fig.11 Propagation Delay vs. Temperature

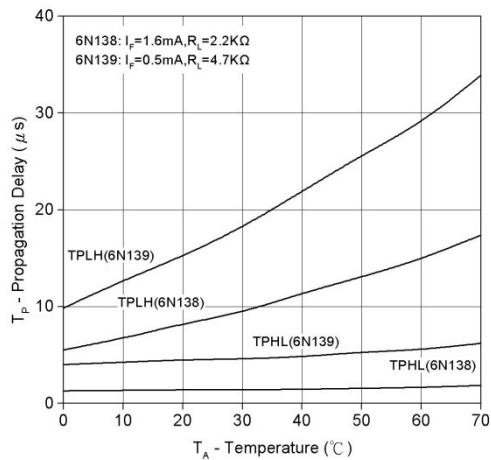

Fig.12 Logic Low Supply Current vs. Input Diode Forward Current

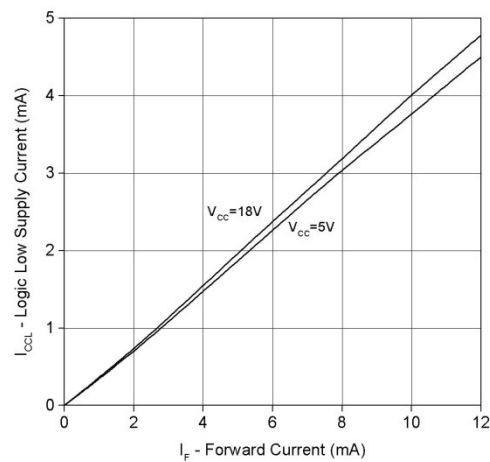

Fig. 13 Switching Time Test Circuit and Waveform

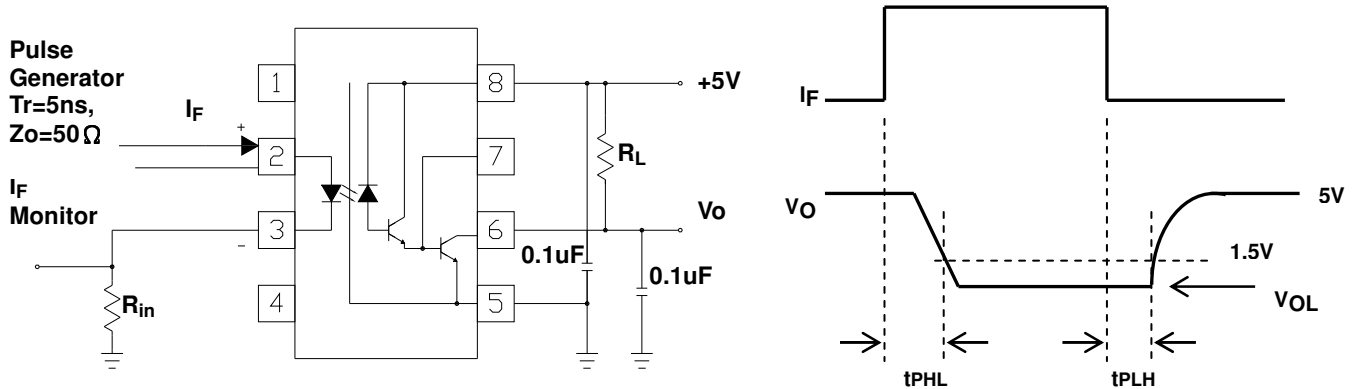
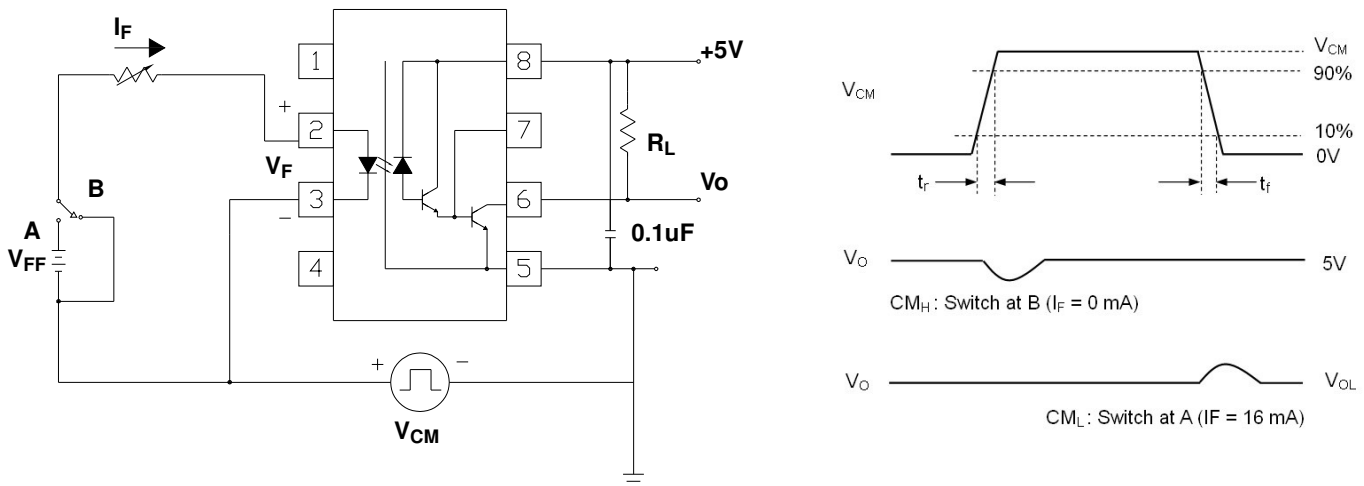

Fig. 14 Common Mode Transient Immunity Test Circuit and Waveform



Note:

*3 Common mode transient immunity in logic high level is the maximum tolerable (positive) dV_{cm}/dt on the leading edge of the common mode pulse signal V_{CM} , to assure that the output will remain in a logic high state (i.e., $V_O > 2.0V$).

Common mode transient immunity in logic low level is the maximum tolerable (negative) dV_{cm}/dt on the trailing edge of the common mode pulse signal, V_{CM} , to assure that the output will remain in a logic low state (i.e., $V_O < 0.8V$).

Order Information

Part Number

6N13XY(Z)-V

Note

- X = Part No. (X = 8 or 9)
- Y = Lead form option (S, S1, M or none)
- Z = Tape and reel option (TA, TB or none).
- V = VDE (optional)

Option	Description	Packing quantity
None	Standard DIP-8	45 units per tube
M	Wide lead bend (0.4 inch spacing)	45 units per tube
S (TA)	Surface mount lead form + TA tape & reel option	1000 units per reel
S (TB)	Surface mount lead form + TB tape & reel option	1000 units per reel
S1 (TA)	Surface mount lead form (low profile) + TA tape & reel option	1000 units per reel
S1 (TB)	Surface mount lead form (low profile) + TB tape & reel option	1000 units per reel

Package Dimension (Dimensions in mm)

Standard DIP Type

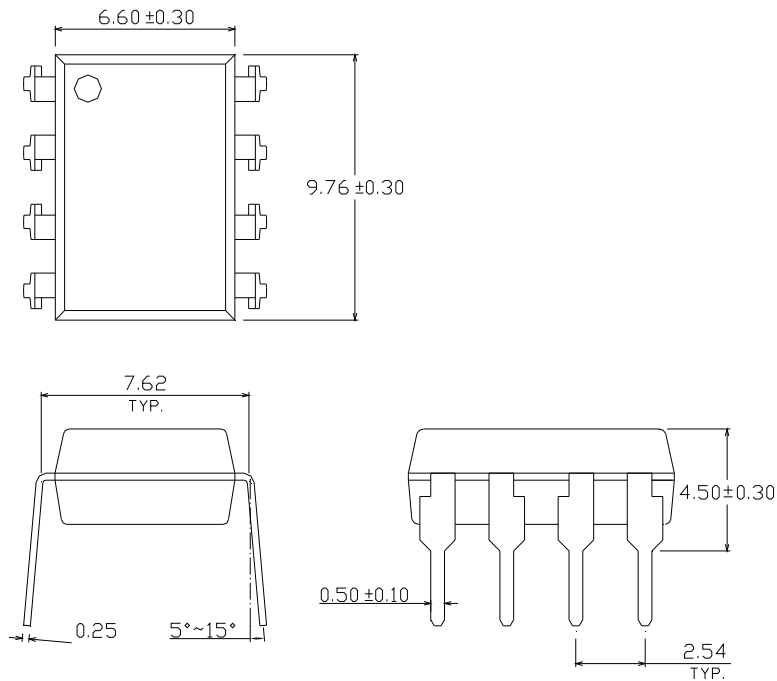

Option M Type

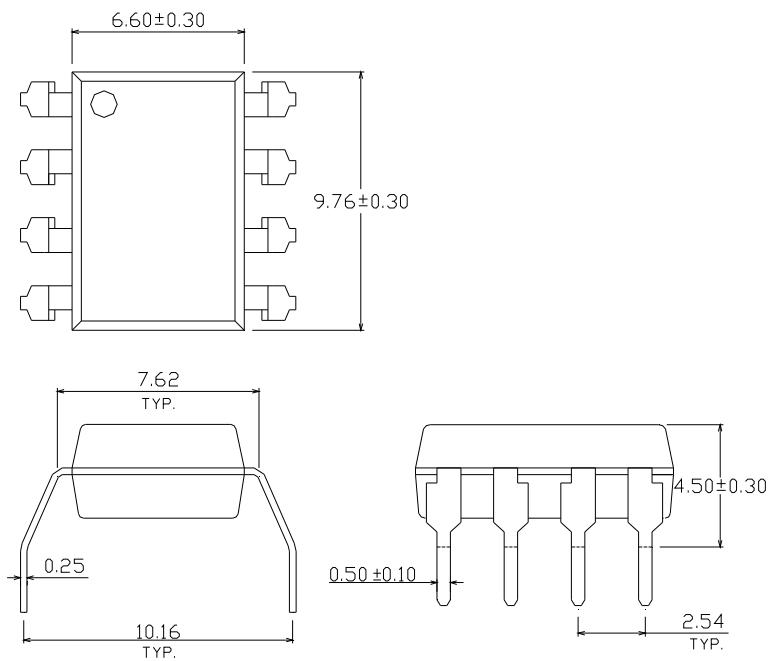

Option S Type

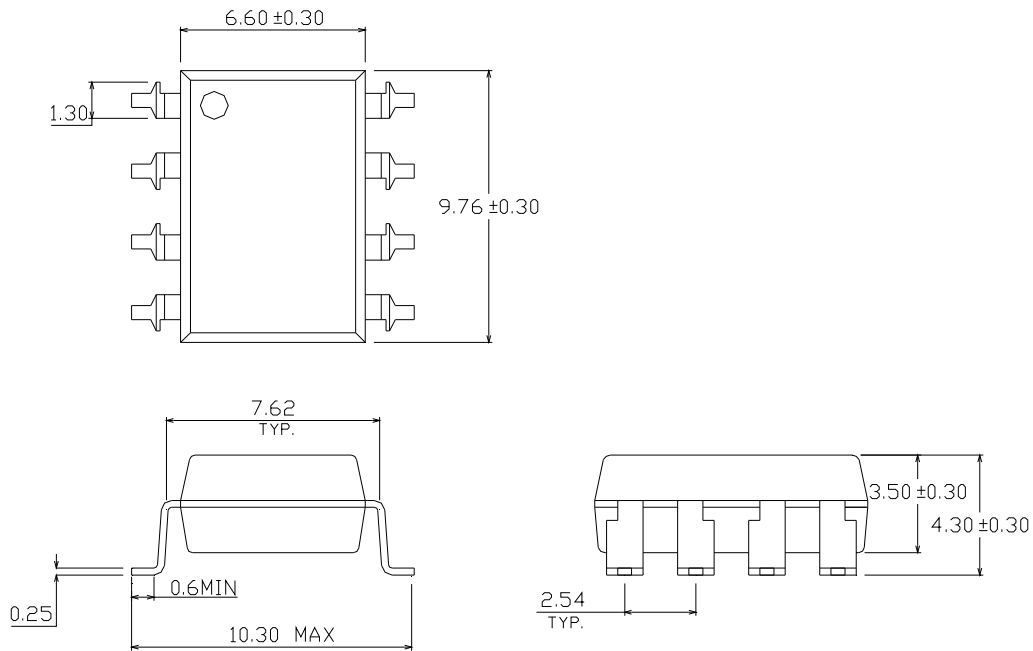

Option S1 Type

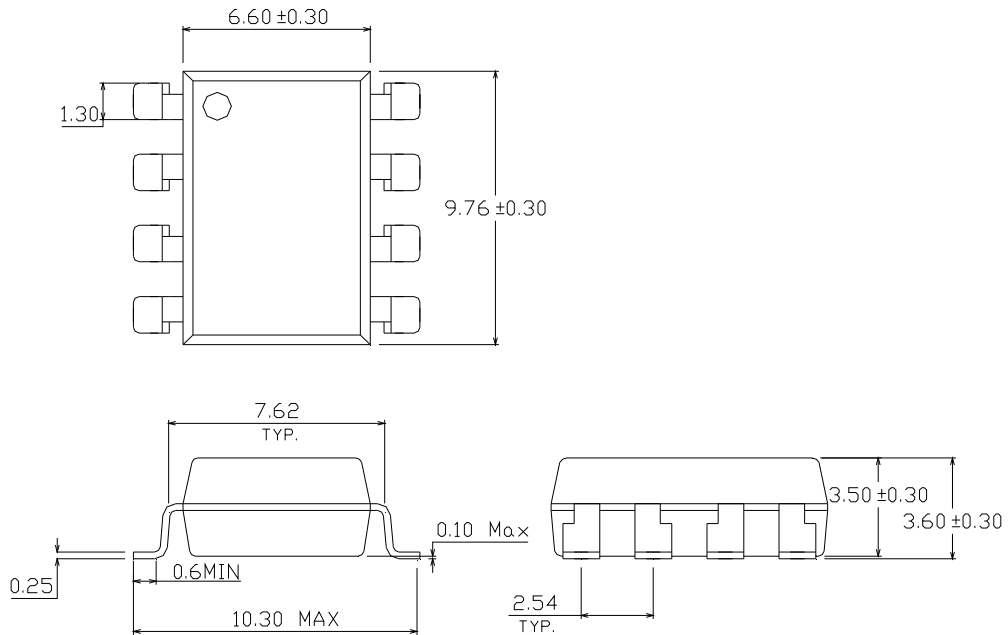

Recommended pad layout for surface mount leadform

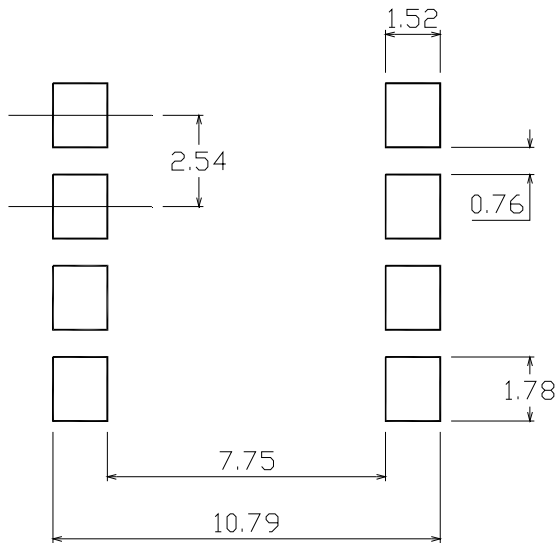

Device Marking

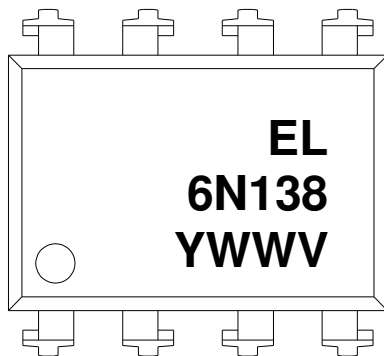

Notes

- EL denotes EVERLIGHT
- 6N138 denotes Device Number
- Y denotes 1 digit Year code
- WW denotes 2 digit Week code
- V denotes VDE (Optional)

Tape & Reel Packing Specifications

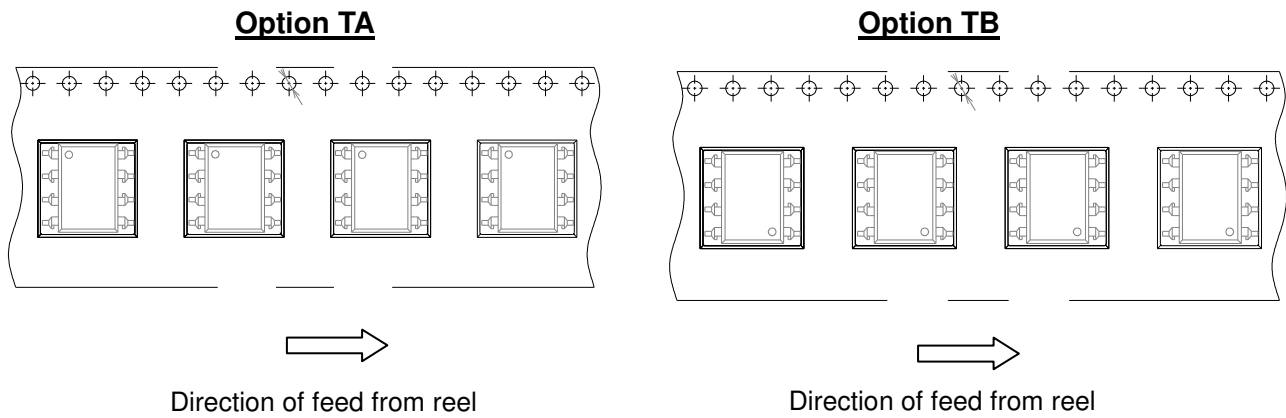

Tape dimensions

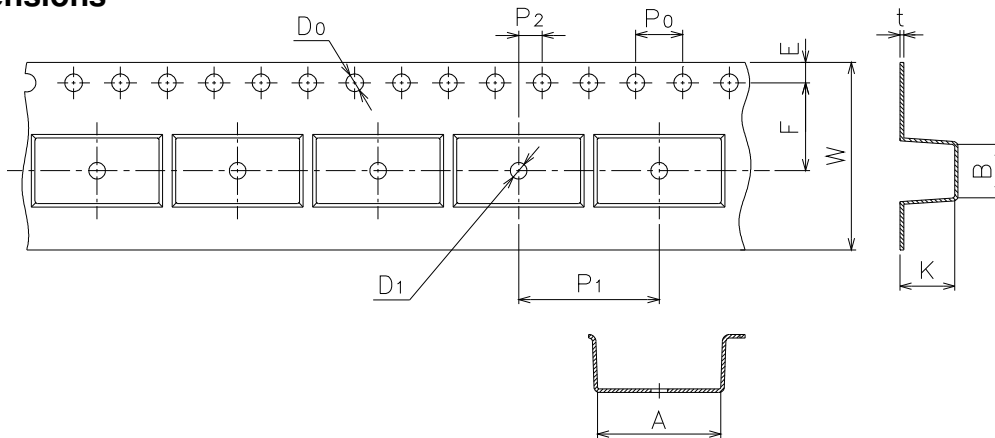

Dimension No.	A	B	Do	D1	E	F
Dimension(mm)	10.4±0.1	10.0±0.1	1.5+0.1/-0	1.5±0.25/-0	1.75±0.1	7.5±0.1
Dimension No.	Po	P1	P2	t	W	K
Dimension(mm)	4.0±0.1	12.0±0.1	2.0±0.05	0.4±0.05	16.0±0.3/	4.5±0.1

Precautions for Use

1. Soldering Condition

1.1 (A) Maximum Body Case Temperature Profile for evaluation of Reflow Profile

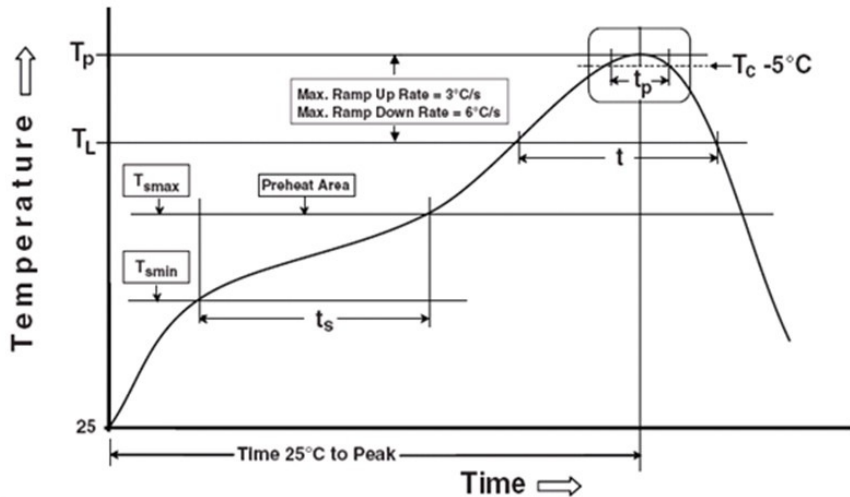

Note:

Reference: IPC/JEDEC J-STD-020D

Preheat

Temperature min (T_{smin})	150 °C
Temperature max (T_{smax})	200 °C
Time (T_{smin} to T_{smax}) (t_s)	60-120 seconds
Average ramp-up rate (T_{smax} to T_p)	3 °C/second max

Other

Liquidus Temperature (T_L)	217 °C
Time above Liquidus Temperature (t_L)	60-100 sec
Peak Temperature (T_p)	260 °C
Time within 5 °C of Actual Peak Temperature: $T_p - 5^\circ\text{C}$	30 s
Ramp- Down Rate from Peak Temperature	6 °C /second max.
Time 25 °C to peak temperature	8 minutes max.
Reflow times	3 times