

## Description

The 6P40368 is a small form factor clock generator with integrated crystal that is intended for low-power, consumer, wearable and smart devices.

The device is designed to support a single 1.8V LVCMOS clock output and a dynamic frequency control for two frequency options. The frequency can be selected by one output pin. The 6P40368 has an embedded crystal to offer a more reliable clock source with small board space requirements.

## Features

- No input clock source requirement
- Dynamic Frequency Control (DFC) is used for output frequency selection
- 1.8V operating voltage
- I<sup>2</sup>C interface
- 2.5 × 2.5 mm 12-DFN package, small form factor

## Typical Applications

- Wireless charge module

## Block Diagram

Figure 1. Block Diagram

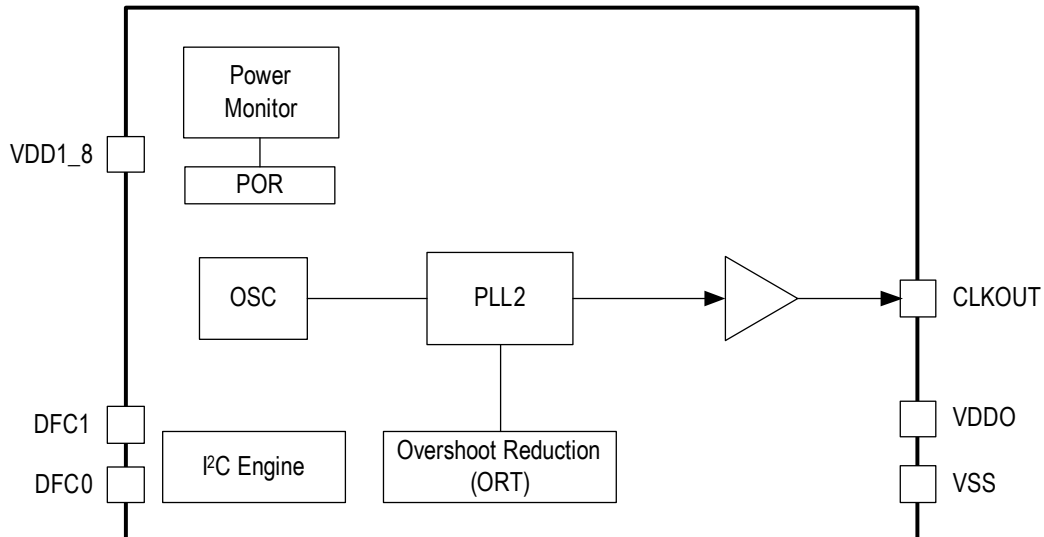

## Pin Assignments

Figure 2. Pin Assignments for 2.5 × 2.5 mm 12-DFN Package

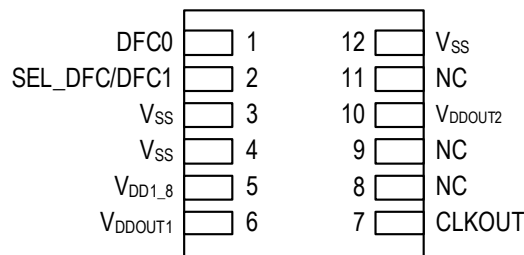

2.5 × 2.5 mm 12-DFN

## Pin Descriptions

Table 1. Pin Descriptions

Number	Name	Type	Description
1	DFC0	Input	Dynamic frequency control pin.
2	SEL_DFC/DFC1	Input	Dynamic frequency control pin selected by SEL_DFC at power-on default.
3	V <sub>SS</sub>	Power	Ground pin.
4	V <sub>SS</sub>	Power	Ground pin.
5	V <sub>DD1_8</sub>	Power	1.8V power rail.
6	V <sub>DDOUT1</sub>	Power	Power supply pin for OUT1 output (1.8V).
7	CLKOUT	Output	1.8V LVCMOS clock output.
8	NC	—	No connect.
9	NC	—	No connect.
10	V <sub>DDOUT2</sub>	Power	Output clock power supply pin 1.8V.
11	NC	—	No connect.
12	V <sub>SS</sub>	Power	Ground pin.

## Frequency Selection

Table 2: Frequency Selection

SEL_DFC	DFC1	DFC0	CLKOUT (MHz)
0	0	0	6.16791
0	0	1	6.1298496
0	1	0	N/A
0	1	1	N/A
1	x	x	x

## ORT – VCO Overshoot Reduction Technology

The 6P40368 supports the VCO overshoot reduction technology to prevent an output clock frequency spike when the device is changing frequency on-the-fly or doing DFC (Dynamic Frequency Control) function. The VCO frequency changes are controlled instead of free-run to targeted frequency.

## Output Clock Test Conditions

Figure 3. LVCMOS Output Clock Test Condition

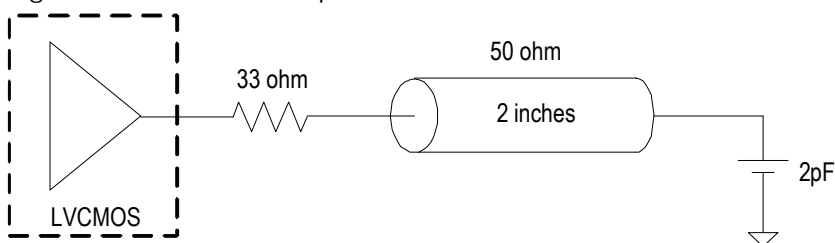

## Absolute Maximum Ratings

Stresses above the ratings listed below can cause permanent damage to the 6P40368. These ratings, which are standard values for IDT commercially rated parts, are stress ratings only. Functional operation of the device at these or any other conditions above those indicated in the operational sections of the specifications is not implied. Exposure to absolute maximum rating conditions for extended periods can affect product reliability. Electrical parameters are guaranteed only over the recommended operating temperature range.

Table 3. Absolute Maximum Ratings<sup>1</sup>

Item	Rating
Supply Voltage, $V_{DD1\_8}$ , $V_{DDOUTx}$	-0.5V to 2.2V
<b>Inputs</b>	
Other inputs	-0.5V to $V_{DD1\_8} / V_{DDOUTx}$
Outputs, $V_{DDOUTx}$ (LVCMOS)	-0.5V to $V_{DDOUTx} + 0.5V$
Outputs, IO (SDA)	10mA
Package Thermal Impedance, $\theta_{JA}$	42°C/W (0mps)
Package Thermal Impedance, $\theta_{JC}$	41.8°C/W (0mps)
Storage Temperature, $T_{STG}$	-65°C to 150°C
ESD Human Body Model	2000V
Junction Temperature	125°C

<sup>1</sup> Permanent device damage may occur if the absolute maximum ratings are exceeded. Functional operation should be restricted to the conditions as specified in the operational sections of this data sheet. Exposure to absolute maximum rating conditions for extended periods may affect device reliability.

## Recommended Operating Conditions

Table 4. Recommended Operating Conditions

Symbol	Parameter	Minimum	Typical	Maximum	Units
$V_{DDOUT1}$	Power Supply Voltage for supporting OUT1	1	—	1.89	V
$V_{DDOUT2}$	Power Supply Voltage for supporting OUT2	1.71	1.8	1.89	
$V_{DD1\_8}$	Power Supply Voltage for Core Logic functions	1.71	1.8	1.89	V
$T_A$	Ambient Operating Temperature	-40	—	85	°C
$C_{LOAD\_OUT}$	Maximum Load Capacitance (1.8V LVCMOS only)	—	5	—	pF
$t_{PU}$	Power-up Time for all $V_{DDs}$ to reach minimum specified voltage (power ramps must be monotonic)	0.05	—	3	ms

## Input Capacitance, LVCMOS Output Impedance, and Internal Pull-down Resistance ( $T_A = +25\text{ }^\circ\text{C}$ )

Table 5. Input Capacitance, LVCMOS Output Impedance, and Internal Pull-down Resistance

Symbol	Parameter	Minimum	Typical	Maximum	Units
$C_{IN}$	Input Capacitance (OE, SDA, SCL)	—	3	7	pF
Pull-down Resistor	OE	—	150	—	k $\Omega$
$R_{OUT}$	LVCMOS Output Driver Impedance ( $V_{DDOUTx} = 1.8V$ )	—	50	—	$\Omega$

## Integrated Crystal Characteristics

Table 6. Crystal Characteristics

Parameter	Test Conditions	Minimum	Typical	Maximum	Units
Mode of Oscillation	—	Fundamental			
Frequency	—	—	26	—	MHz
Frequency Tolerance <sup>1</sup>	—	—	—	$\pm 20$	ppm
Equivalent Series Resistance (ESR)	—	—	10	100	$\Omega$
Shunt Capacitance	—	—	2	7	pF
Load Capacitance ( $C_L$ )	—	6	8	10	pF
Maximum Crystal Drive Level	—	—	—	100	$\mu W$

<sup>1</sup> Frequency tolerance includes initial frequency, over-temperature range and aging data.

## Electrical Characteristics

 Table 7. DC Electrical Characteristics <sup>1,2</sup>

Symbol	Parameter	Conditions	Minimum	Typical	Maximum	Units
$I_{DD}$	Operation Supply Current	$V_{DD} = V_{DDOUTx} = V_{DD1.8} = 1.8V$ ; OUT = 6.1679100MHz with load.	—	2.5	—	mA
		$V_{DD} = V_{DDOUTx} = V_{DD1.8} = 1.8V$ ; OUT = 6.1298496MHz with load.	—	2.5	—	mA
$I_{DDPD}$	Power Down Current	PD asserted with $V_{DD1.8}$ and $V_{DDOUTx}$ on.	—	390	—	$\mu A$

<sup>1</sup> Single CMOS driver active.

<sup>2</sup> OUT current measured with 2-inch transmission line and 2pF load.

Table 8. Input Parameters <sup>1</sup>

 Supply Voltage  $V_{DD1\_8} = 1.8V \pm 5\%$ ,  $V_{DDOUTx} = 1.8V \pm 5\%$ ,  $T_A = -40^\circ C$  to  $+85^\circ C$ .

Symbol	Parameter	Conditions	Minimum	Typical	Maximum	Units
$I_{IL}$	Input Leakage Low Current for OE1	$V_{IN} = GND$ at OE1 pin.	150	—	5	$\mu A$
$I_{IH}$	Input Leakage High Current for OE1	$V_{IN} = 1.89V$ .	—	—	20	$\mu A$
$I_{OE1}$	Input Leakage Current	$V_{IN} = 1.89V$ at OE1 pin.	—	—	120	$\mu A$

<sup>1</sup> Guaranteed by design and characterization, not 100% tested in production.

Table 9. DC Electrical Characteristics for 1.8V LVCMOS

 $V_{DDOUTx} = 1.8V \pm 5\%$ ,  $T_A = -40^\circ C$  to  $85^\circ C$ .

Symbol	Parameter	Conditions	Minimum	Typical	Maximum	Units
$V_{OH}$	Output High Voltage	$I_{OH} = -8mA$ .	$0.7 \times V_{DDOUTx}$	—	$V_{DDOUTx}$	V
$V_{OL}$	Output Low Voltage	$I_{OL} = 8mA$ .	0.1	—	0.15	V
$I_{OZDD}$	Output Leakage Current	Tri-state outputs, $V_{DDOUTx} = 1.89V$ .	—	—	3	$\mu A$
$V_{IH}$	Input High Voltage	Single-ended inputs – OE, SDA, SCL.	$0.65 \times V_{DDOUTx}$	—	$V_{DDOUTx} + 0.3$	V
$V_{IL}$	Input Low Voltage	Single-ended inputs – OE, SDA, SCL.	GND - 0.3	—	$0.35 \times V_{DDOUTx}$	V

## AC Electrical Characteristics

Table 10. AC Timing Electrical Characteristics

 $V_{DD1\_8} = 1.8V \pm 5\%$ ,  $V_{DDOUTx} = 1.8V \pm 5\%$ ,  $T_A = -40^\circ C$  to  $+85^\circ C$ ; spread spectrum = off.

Symbol	Parameter	Conditions	Minimum	Typical	Maximum	Units
$f_{OUT}^1$	Output Frequency	SEL_DFC = 0, DFC[1:0] = 01.	—	6.16791	—	MHz
		SEL_DFC = 0, DFC[1:0] = 00.	—	6.1298496	—	MHz
t0	Accuracy <sup>4</sup>	Average.	—	—	50	ppm
t1	Output Duty Cycle	LVCMOS clock < 120MHz.	45	—	55	%
t2	Rise/Fall, SLEW[0] = 1	Single-ended LVCMOS output clock rise and fall time, 20% to 80% of $V_{DDOUT} 1.8V$ .	—	2.5	—	ns
t3	Clock Jitter	Cycle-to-cycle jitter (peak-to-peak), multiple output frequencies switching, differential outputs (1.8V nominal output voltage).	—	50	150	ps
t4 <sup>2</sup>	Lock Time	PLL lock time from power-up.	—	—	20	ms
t5 <sup>3</sup>	Lock Time	PLL lock time from shutdown mode.	—	0.1	2	ms

<sup>1</sup> Practical lower frequency is determined by loop filter settings.

<sup>2</sup> Includes loading the configuration bits from OTP to PLL registers. It does not include OTP programming/write time.

<sup>3</sup> Actual PLL lock time depends on the loop configuration.

<sup>4</sup> Includes initial frequency, over-temperature range and aging data.

## Package Outline Drawings

The package outline drawings are located at the end of this document. The package information is the most current data available.

## Ordering Information

Orderable Part Number	Package	Shipping Packaging	Temperature
6P40368NDGI	2.5 × 2.5 mm, 0.4mm pitch 12-DFN	Cut Tape	-40° to +85°C
6P40368NDGI8	2.5 × 2.5 mm, 0.4mm pitch 12-DFN	Reel	-40° to +85°C

## Marking Diagram

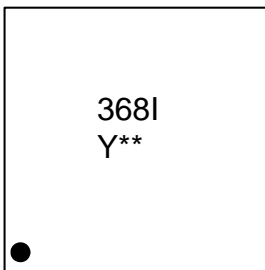

1. Line 1 is the truncated part number.
2. "Y" is the last digit of the year the part was assembled.
3. "\*\*" denotes sequential lot number.

## Revision History

Revision Date	Description of Change
August 16, 2018	<ul style="list-style-type: none"> <li>▪ Updated Absolute Maximum Ratings table.</li> <li>▪ Updated Package Outline Drawings section.</li> </ul>
October 30, 2017	Initial release.



Corporate Headquarters  
 6024 Silver Creek Valley Road  
 San Jose, CA 95138 USA  
[www.IDT.com](http://www.IDT.com)

Sales  
 1-800-345-7015 or 408-284-8200  
 Fax: 408-284-2775  
[www.IDT.com/go/sales](http://www.IDT.com/go/sales)

Tech Support  
[www.IDT.com/go/support](http://www.IDT.com/go/support)

DISCLAIMER Integrated Device Technology, Inc. (IDT) and its affiliated companies (herein referred to as "IDT") reserve the right to modify the products and/or specifications described herein at any time, without notice, at IDT's sole discretion. Performance specifications and operating parameters of the described products are determined in an independent state and are not guaranteed to perform the same way when installed in customer products. The information contained herein is provided without representation or warranty of any kind, whether express or implied, including, but not limited to, the suitability of IDT's products for any particular purpose, an implied warranty of merchantability, or non-infringement of the intellectual property rights of others. This document is presented only as a guide and does not convey any license under intellectual property rights of IDT or any third parties.

IDT's products are not intended for use in applications involving extreme environmental conditions or in life support systems or similar devices where the failure or malfunction of an IDT product can be reasonably expected to significantly affect the health or safety of users. Anyone using an IDT product in such a manner does so at their own risk, absent an express, written agreement by IDT.

Integrated Device Technology, IDT and the IDT logo are trademarks or registered trademarks of IDT and its subsidiaries in the United States and other countries. Other trademarks used herein are the property of IDT or their respective third party owners. For datasheet type definitions and a glossary of common terms, visit [www.idt.com/go/glossary](http://www.idt.com/go/glossary). Integrated Device Technology, Inc. All rights reserved.

DATE CREATED	REVISIONS		
	REV	DESCRIPTION	AUTHOR
06/21/16	00	INITIAL RELEASE	JH
12/08/17	01	CORRECT DIMENSION	JH

NOTE: REFER TO DCP FOR OFFICIAL RELEASE DATE

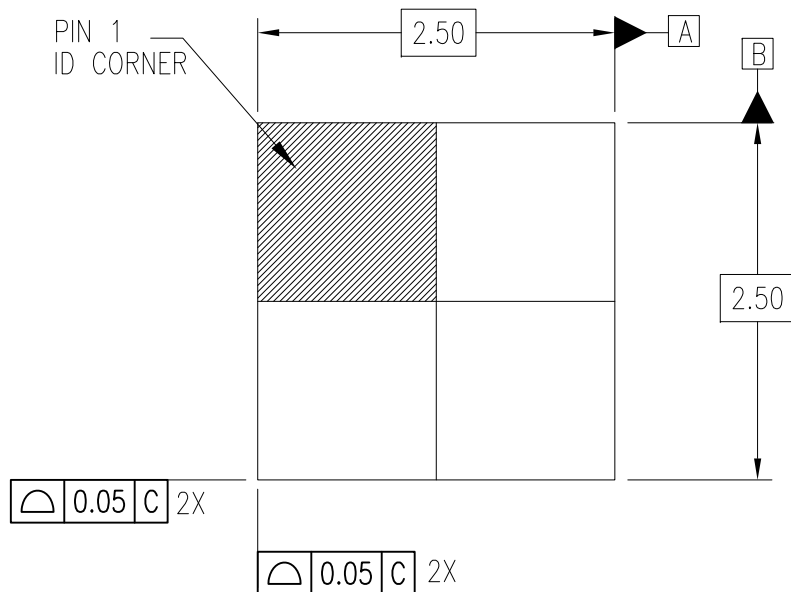

TOP VIEW

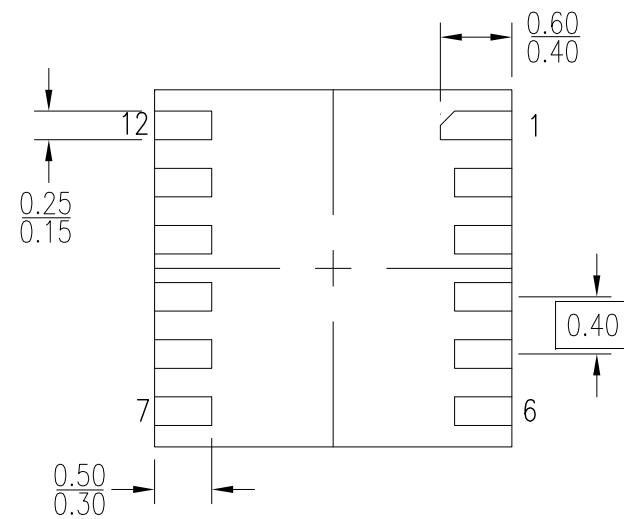

BOTTOM VIEW

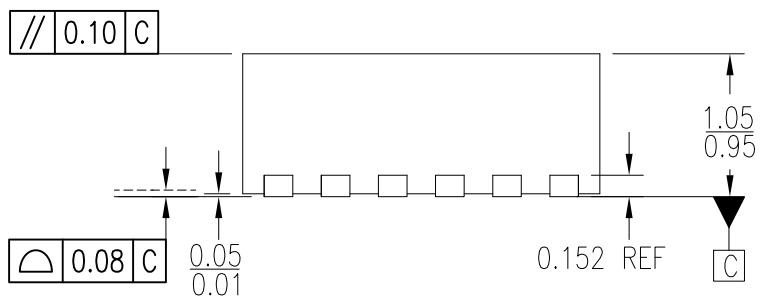

SIDE VIEW (ROTATE 90 DEG.)

- NOTE:
1. DIMENSIONING AND TOLERANCING CONFORM TO ASMEY14.5-2009.
  2. ALL DIMENSIONS ARE IN MILLIMETERS.

TOLERANCES UNLESS SPECIFIED DECIMAL ANGULAR X± .1 ±1° XX± .05 XXX± .030	 6024 Silver Creek Valley Road San Jose CA 95138 PHONE: (408) 284-8200 FAX: (408) 284-3572 <a href="http://www.IDT.com">www.IDT.com</a>	
	TITLE ND/NDG12 Package Outline Drawing 2.50 x 2.50 x 1.00 mm Body 0.40mm Pitch DFN	
SIZE C	DRAWING No. PSC-4665	REV 01
DO NOT SCALE DRAWING		SHEET 1 OF 2