

1 2 3

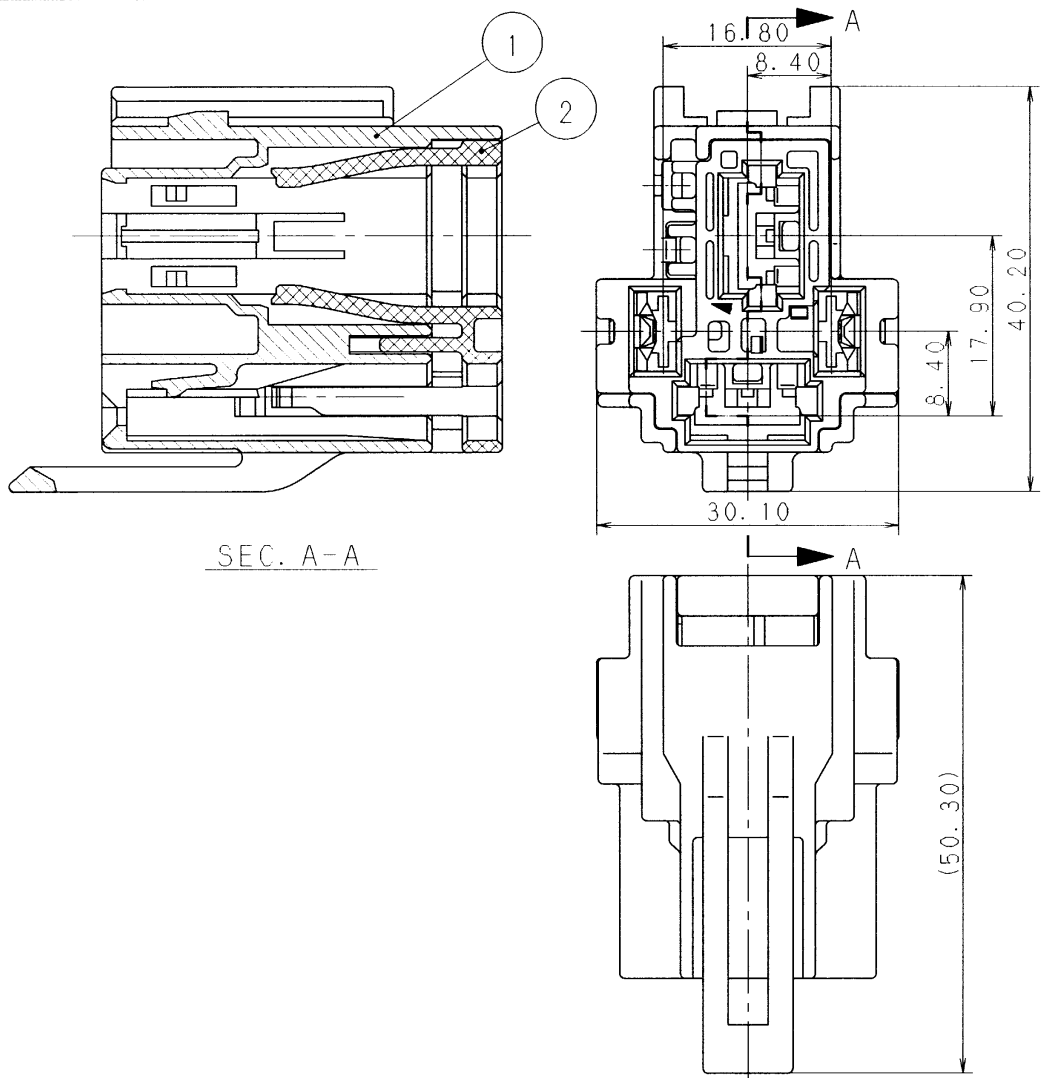

SUB ASS'Y PART NO.	NO.	PART NO.	MATERIAL	COLOR	QTY.
7223-6146-30	①	7123-6146-30	PBT	BLACK	1
	②	7157-6315	PBT	NATURAL	1

注記

1. 適用端子品番 Mタイプ(F): 7116-2870 ETC.
Lタイプ(F): 7116-3250 ETC.

NOTE

1. APPLICABLE TERMINAL PART NO. M TYPE (F) : 7116-2870 ETC.
L TYPE (F) : 7116-3250 ETC.

ISSUE MARK

				CUSTOMER				MATERIAL SPEC.				TREAT. & FIN.			
				CUSTOMER PART NO.				CUSTOMER DWG NO.							
97.03.25				NEW				C97-L603				M. T			
LET DATE				REVISION RECORD				NO.				CHKD			
				OFFICE				TRIAL PART NO.				NAME			
				VENDOR				VENDOR NO.				ABS POWER RELAY HOUSING 4P			
				GENERAL TOLERANCE								SUB ASS'Y			
	10MAX	50MAX	100MAX	250MAX	2500VR	ANGLE	ECCENT	DWG TYPE	DWG SOURCE	DWG DATE	UNIT	SCL	ANGLE	PART NO.	
A	±0.15	±0.2	±0.3	±0.5	±0.75	±30'	0.1	R	NEW	97.03.25	mm	2/1	3	7223-6146-30	
B	±0.2	±0.3	±0.55	±0.95	±1.4	±30'	0.1	APPROVED	CHECKED	CHECKED	DESIGN	DRAWN	DWG NO.	7223-6146-30:R	SET DWG NO.
©	±0.3	±0.5	±0.8	±1.4	±2	±30'	0.15		石川	工藤	Y. SHINJI	SATOH			
SPECIFIED				MASS				g				YAZAKI CORPORATION			
								97.4.4				97.4.01			
												94.10.05			
												97.03.25			

1 2 3

