

INDEX

PAGE TITLE	PAGE
TITLE BLOCK/CONNECTOR SPECIFICATIONS	1
REVISION BLOCK AND GENERAL NOTES	2
ASSEMBLY DIAGRAM/KEYING TABLE	3
PART BLOCK	4
EXPLODED VIEW/COMPONENT MATERIAL SPECIFICATIONS	5
DATUM LOCATIONS AND FEATURE CONTROL VIEWS	6
CONNECTOR DIMENSIONS	7
INTERFACE AND PINOUT	8

GM DRE NAME

GAVRIL CRET

*Lab Day 1/8/2016*

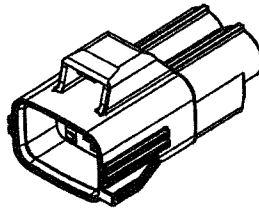

13510029  
SCALE 1/1

NOTES:

- CONNECTOR CLASSIFICATION: USCAR-2, REV 6, FEBRUARY 2013 (TC3/VC2/SC2/MF2)
- CONNECTOR-CONNECTOR MATING FORCE: (36N MAX)
- TERMINAL CAVITY: 6.3mm YESC SEALED
- TERMINALS VALIDATED FOR THIS CONNECTOR: YAZAKI YESC 6.3
- FOR TERMINAL CAVITY COMPATIBILITY REFERENCE CG-2740
- MATING PART NUMBER: SEE TABLE ON PAGE 3
- MAX WIRE OD: 4.30mm  
MIN WIRE OD: 1.40mm
- PART TO COMPLY WITH YPES-31-038 REQUIREMENTS.



DO NOT SCALE

METRIC  
DIMENSIONS SHOWN IN  
MILLIMETERS UNLESS  
OTHERWISE SPECIFIED

SUPPLIER NAME



DRAFTER

N. MYERS

DATE

15JU15

APVD1

JUSTIN  
GERWATOWSKI

Digital signed by justin.gerwatowski@us.yazaki.com  
Date: 2016.01.07 09:34:05-0500

APVD2

APVD3

APVD4

APVD5

DRAWING NAME

2P 6.3 YESC SEALED MALE CONNECTOR SUB-ASSEMBLY

DRAWING NUMBER

13510029

DRAWING STATUS

ST

REV

PDI

001

PAGE NUMBER

1 of 8



PAGE TITLE

TITLE BLOCK/  
CONNECTOR SPECIFICATIONS

DRAWING NUMBER

13510029

DRAWING STATUS

ST

REV

PDI

001

PAGE NUMBER

1 of 8

1

2

3

4

PAGE	DRAWING STATUS					REVISION HISTORY	AUTH	DR	CK	ENG
	DATE	ST	REV	CHG	PDI					
1-8	28MY15		001			INITIAL RELEASE EWO: 2270994	M. MEARING	JG		NM

B

B

NOTES:

- 1. CLIP SLOT DRAWING PART NUMBER: N/A
- 2. HANDLING MANUAL NUMBER: YPES-15-300
- 3. PRODUCT SPECIFICATION NUMBER: N/A
- 4. CONNECTOR SHIPPED WITH TPA IN PRE-SET CONDITION
- 5. DRESS COVER PART NUMBER: N/A

A

A

	PAGE TITLE REVISION BLOCK AND GENERAL NOTES	DRAWING NUMBER 13510029	DRAWING STATUS			PAGE NUMBER 2 of 8
			ST	REV	PDI	
				001		

1

2

3

4

1

2

3

4

#	SUPPLIER PART NUMBER	GM PART NUMBER	KEYWAY	COLOR	MATING SUPPLIER PART NUMBER	GM MATING PART NUMBER
1	7286-9860-10	13510029	A	DARK GRAY	7287-6196-10 7297-6197-10	13596768 13587878
2						
3						
4						

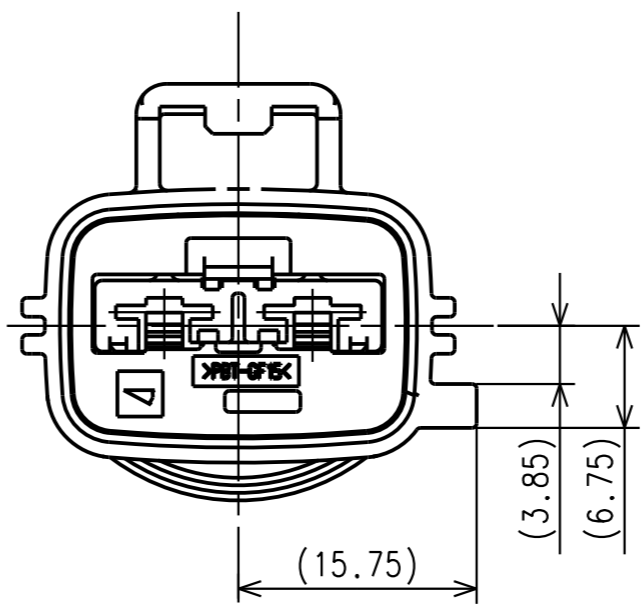

KEYWAY A

SCALE 2/1

	PAGE TITLE ASSEMBLY DIAGRAM / KEYING TABLE	DRAWING NUMBER 13510029	DRAWING STATUS			PAGE NUMBER 3 OF 8
			ST	REV	PDI	
				001		

1

2

3

4

1

2

3

4

PARTS SHOWN ON DRAWING

DWG ITEM	SUPPLIER PART NUMBER	GM PART NUMBER	KEYWAY	COLOR	DESCRIPTION	MASS (g)	PART NAME	NOTES
1	7286-9860-10	13510029	A	DARK GRAY	WITH TPA	(11.79)	2P 6.3 YESC SEALED MALE CONNECTOR SUB-ASSEMBLY	
2								
3								
4								
5								
6								

B

B

A

A

	PAGE TITLE PART BLOCK	DRAWING NUMBER 13510029	DRAWING STATUS			PAGE NUMBER 4 of 8
			ST	REV	PDI	
				001		

1

2

3

4

1

2

3

4

NO.	PART TYPE	MATERIAL	COLOR
①	HOUSING	>PBT-GF15<	DARK GRAY
②	TERMIAL POSITION ASSURANCE	>PBT-GF15<	NATURAL
③			
④			

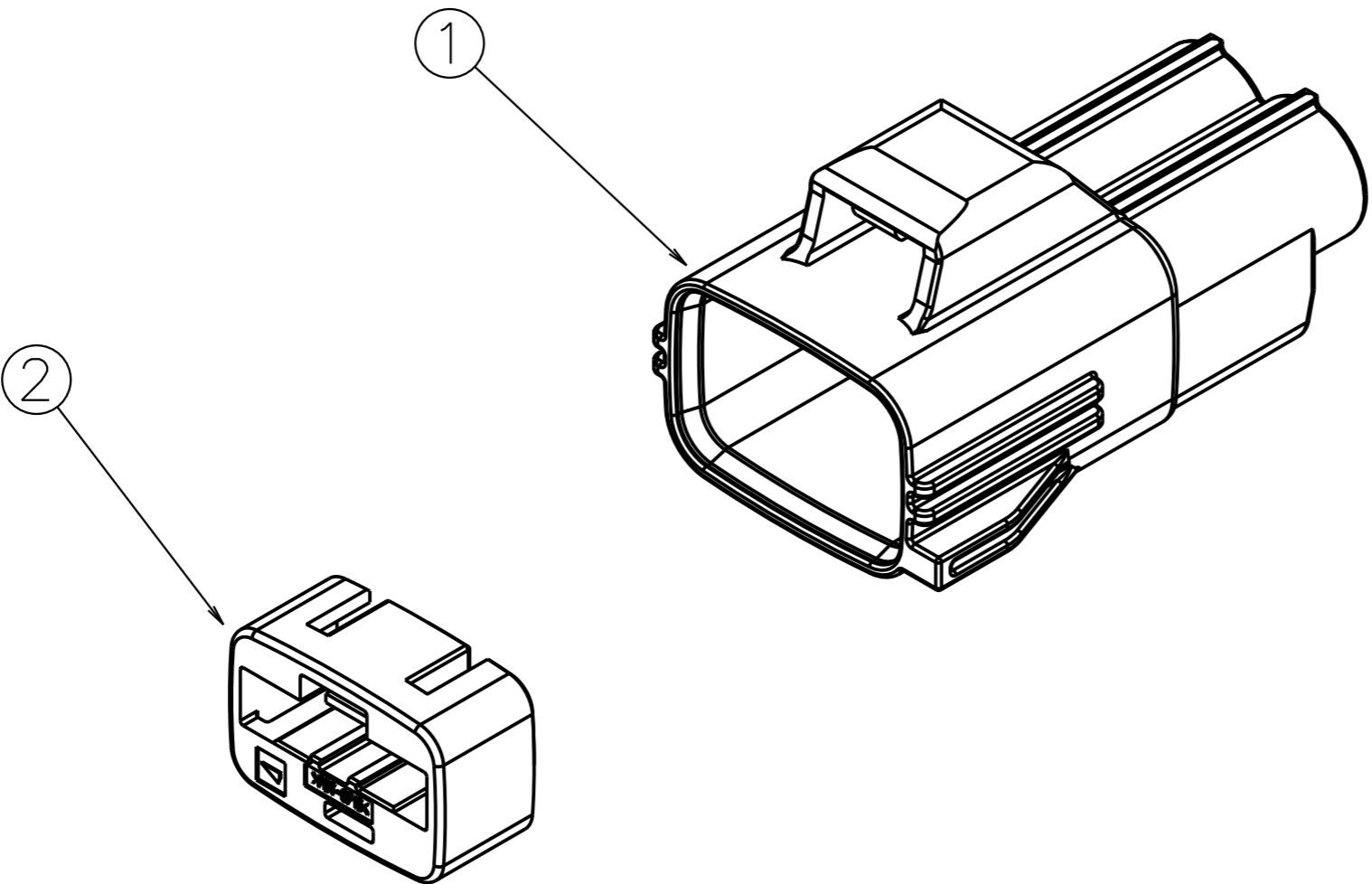

SCALE 1/1

GM	PAGE TITLE EXPLODED VIEW/ COMPONENT MATERIAL SPECIFICATIONS	DRAWING NUMBER 13510029	DRAWING STATUS			PAGE NUMBER 5 of 8
			ST	REV	PDI	
				001		

1

2

3

4

1

2

3

4

NOTES:  
 1. DATUM A REPRESENTS THE PART SURFACE THAT WILL BOTTOM OUT FIRST DURING MATING.

B

B

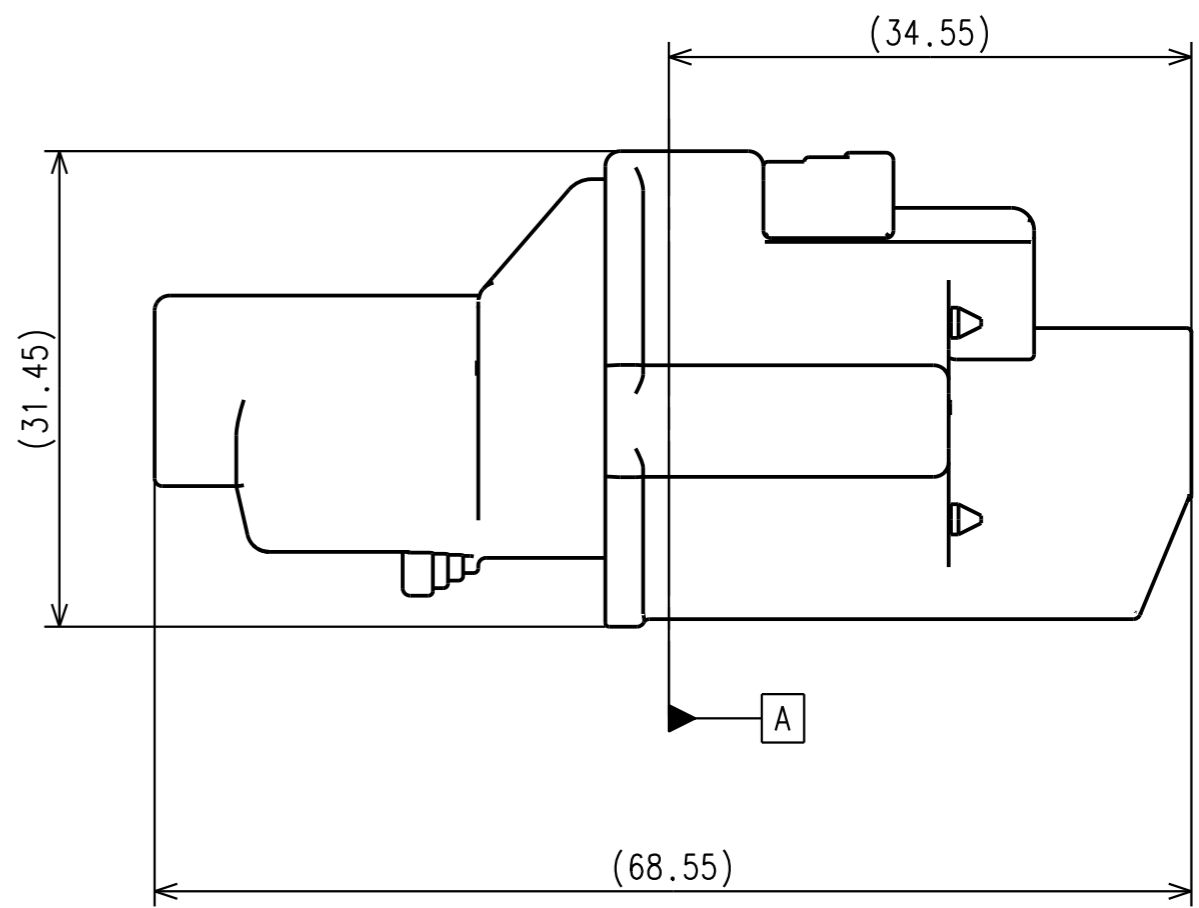
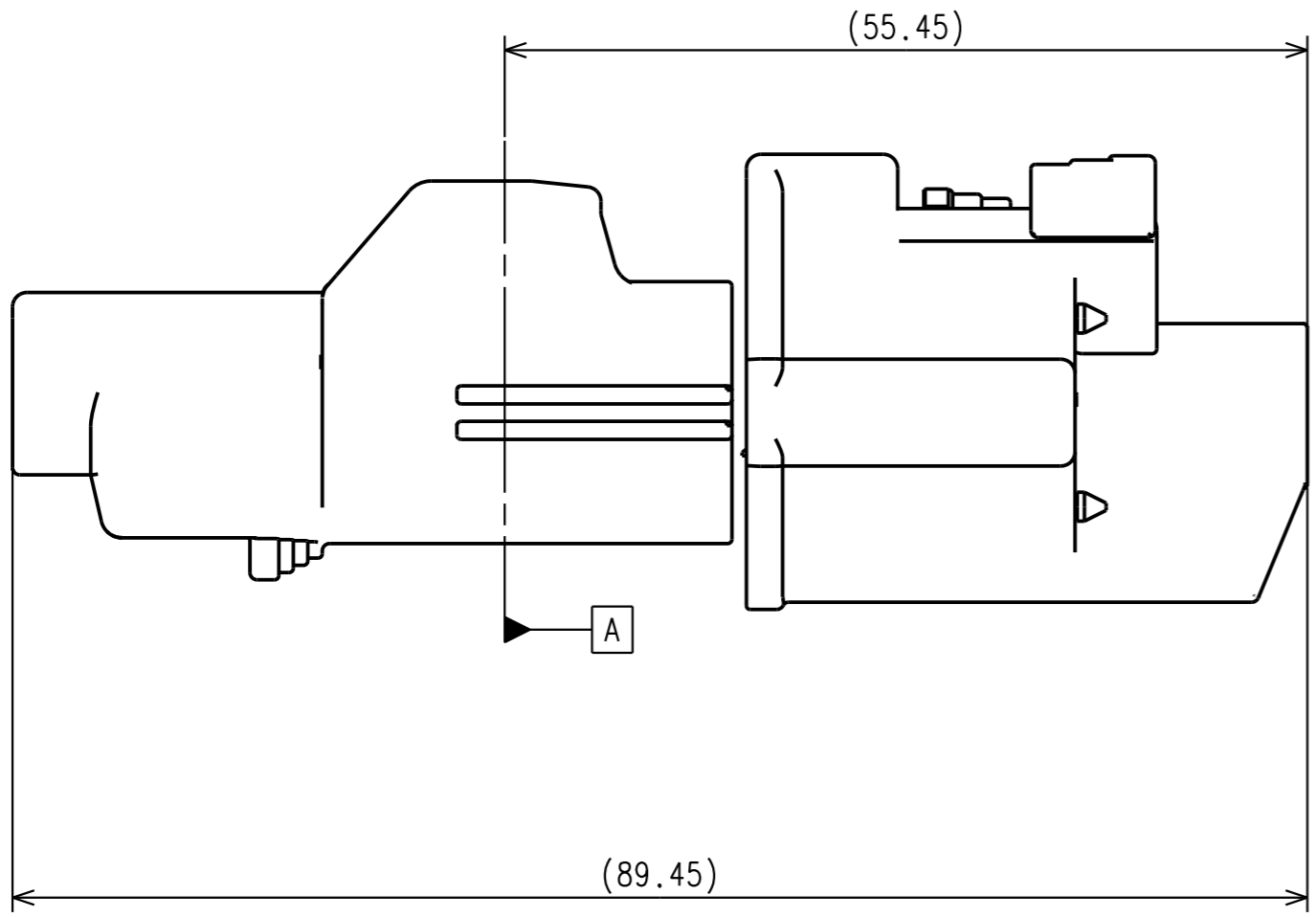

CONNECTOR ASSEMBLY IN FULLY MATED POSITION

SCALE 2/1

A

A



PAGE TITLE  
 DATUM LOCATIONS /  
 FEATURE CONTROL VIEWS

DRAWING NUMBER  
 13510029

DRAWING STATUS		
ST	REV	PDI
	001	

PAGE NUMBER  
 6 of 8

1

2

3

4

1

2

3

4

B

B

A

A

( $\phi 34.0$ ) MIN PASS THROUGH WITH NO CLEARANCE

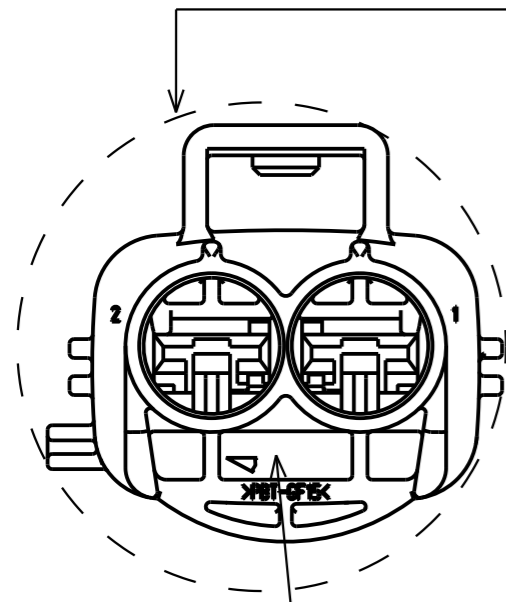

TOOL CAVITY AND MOLDING NO.

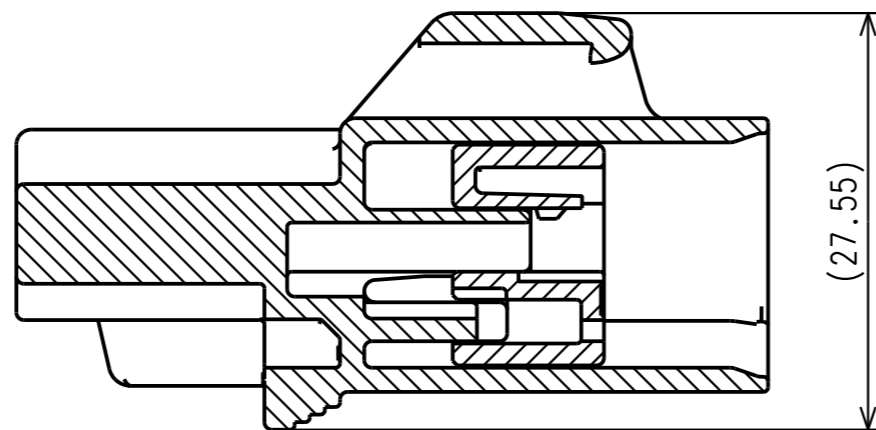

(27.55)

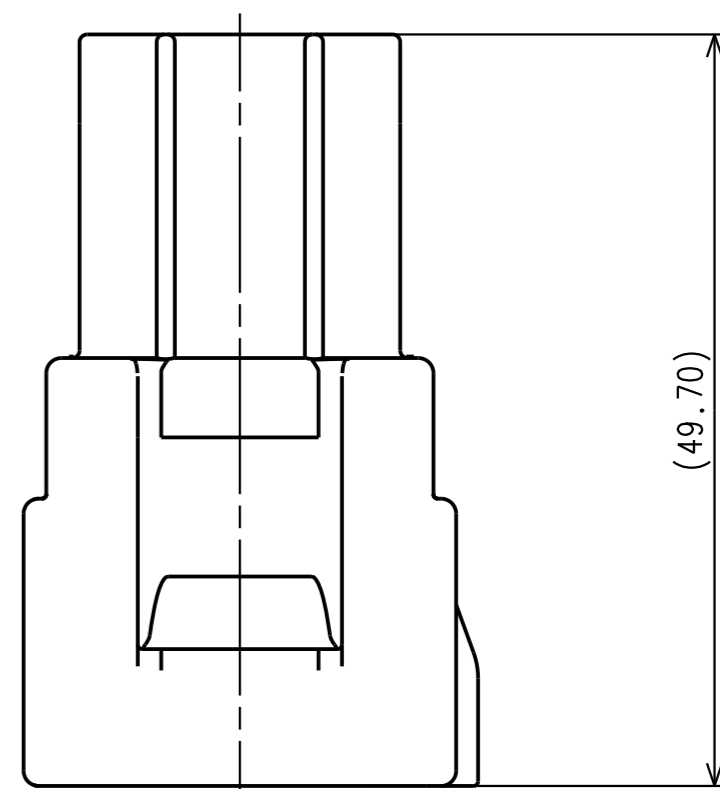

(49.70)

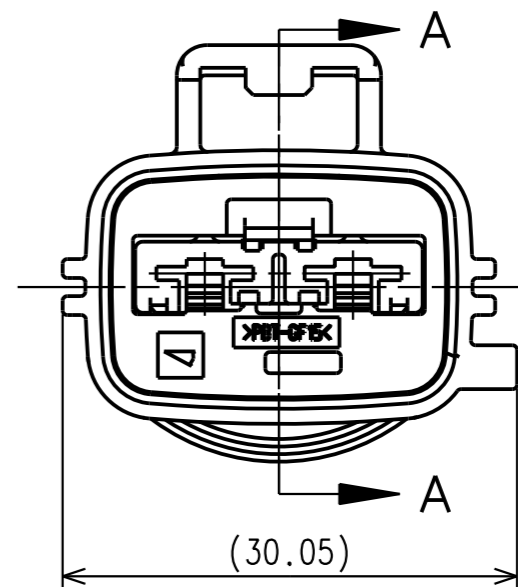

(30.05)

SCALE 1/1



PAGE TITLE

CONNECTOR DIMENSIONS

DRAWING NUMBER

13510029

DRAWING STATUS

ST	REV	PDI
----	-----	-----

001

PAGE NUMBER

7 OF 8

1

2

3

4