

7289-7459-40
KEYWAY A

(2/1)

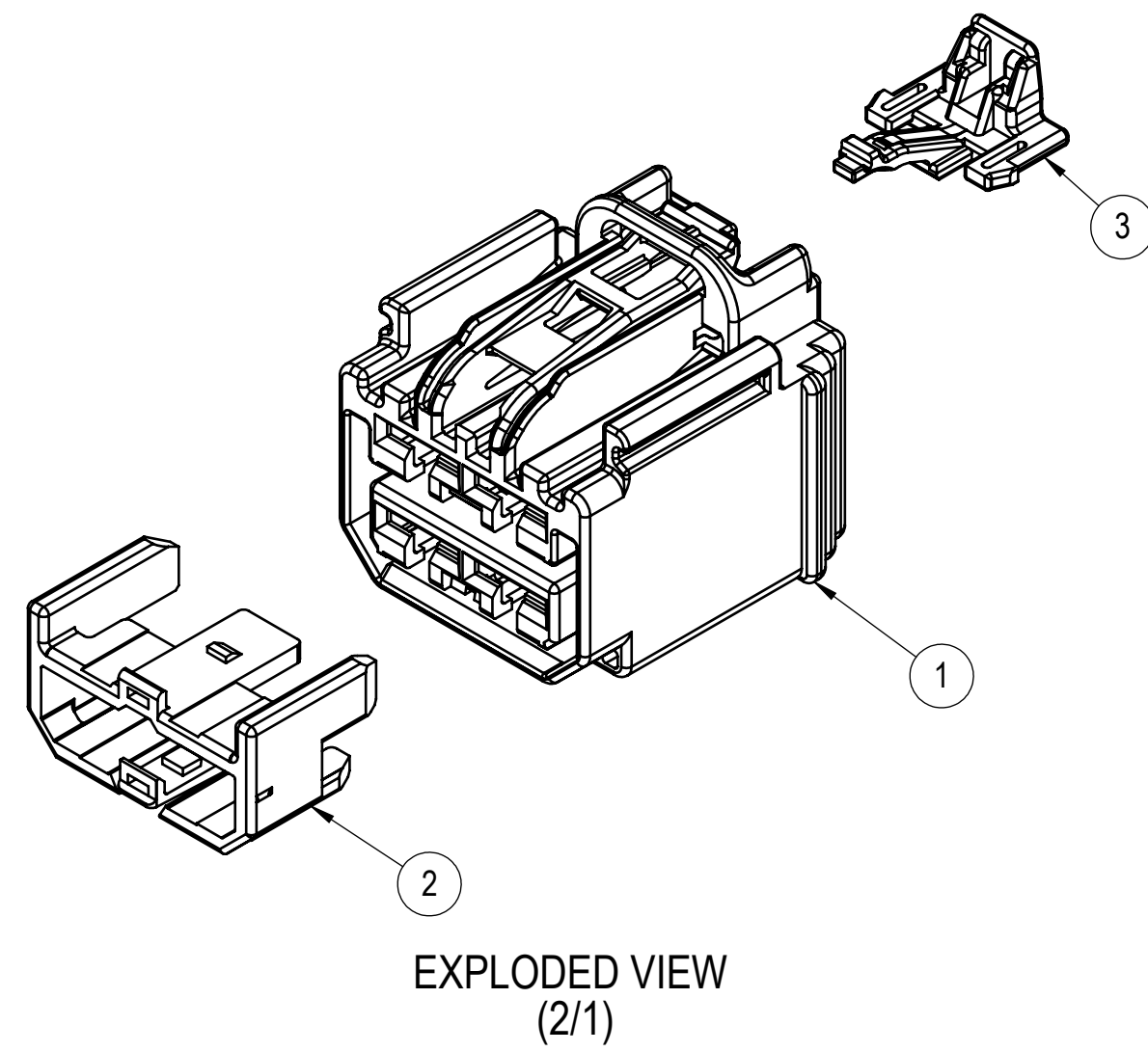

EXPLODED VIEW
(2/1)

SUB-ASSEMBLY PART NUMBER	NO.	PART NUMBER	PART NAME	MATERIAL	COLOR	QUANTITY
7289-7459-40	①	7189-7459-40	4P 6.3mm YESC KAIZEN UNSEALED FEMALE CONNECTOR HOUSING	PBT-GF15	LIGHT GRAY	1
	②	7158-4229	4P 6.3mm YESC KAIZEN UNSEALED FEMALE CONNECTOR TPA	PBT	NATURAL	1
	③	7172-1375-50	YESC KAIZEN LARGE LOCK CPA	PBT-GF15	RED	1

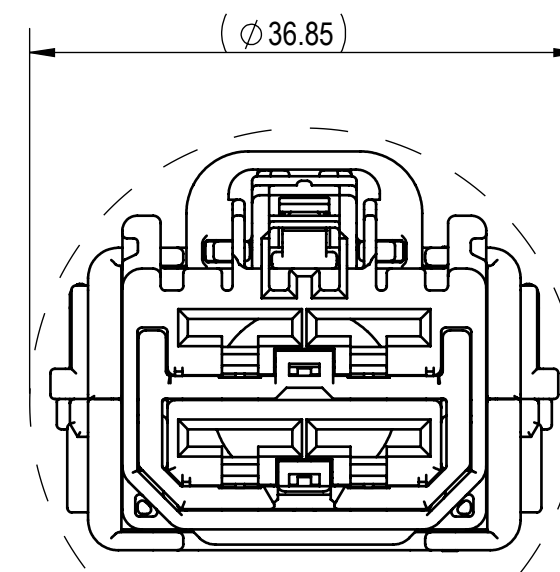

△ RECOMMENDED PASS-THROUGH HOLE DIMENSION WITH 7174-2215-30 AND 7174-2216-30 (1mm CLEARANCE ALL AROUND)
(2/1)

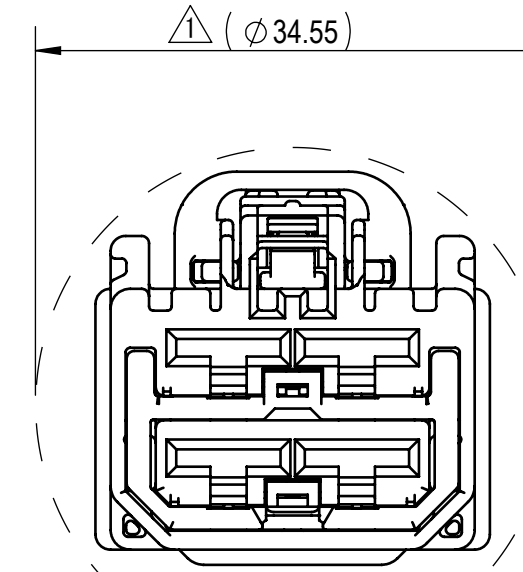

△ RECOMMENDED PASS-THROUGH HOLE DIMENSION (1mm CLEARANCE ALL AROUND)
(2/1)

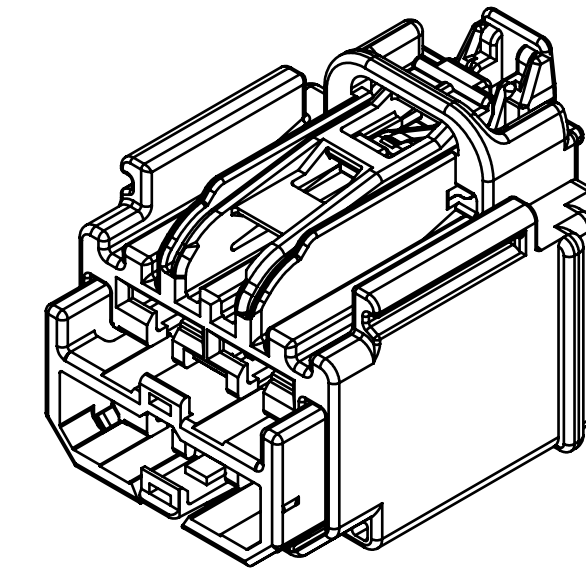

FRONT ISOMETRIC VIEW
(2/1)

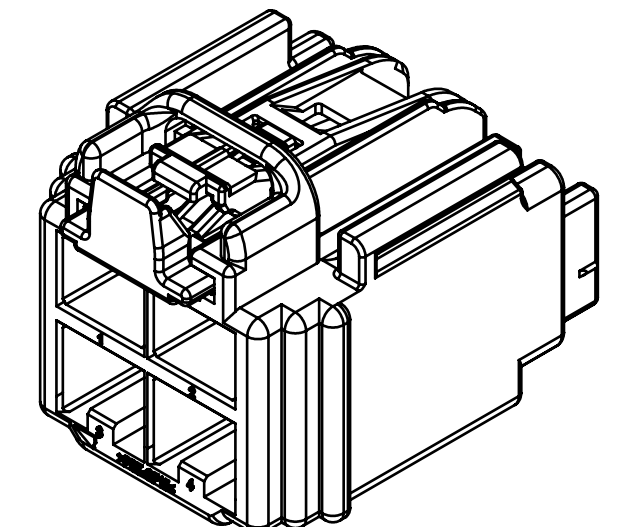

REAR ISOMETRIC VIEW
(2/1)

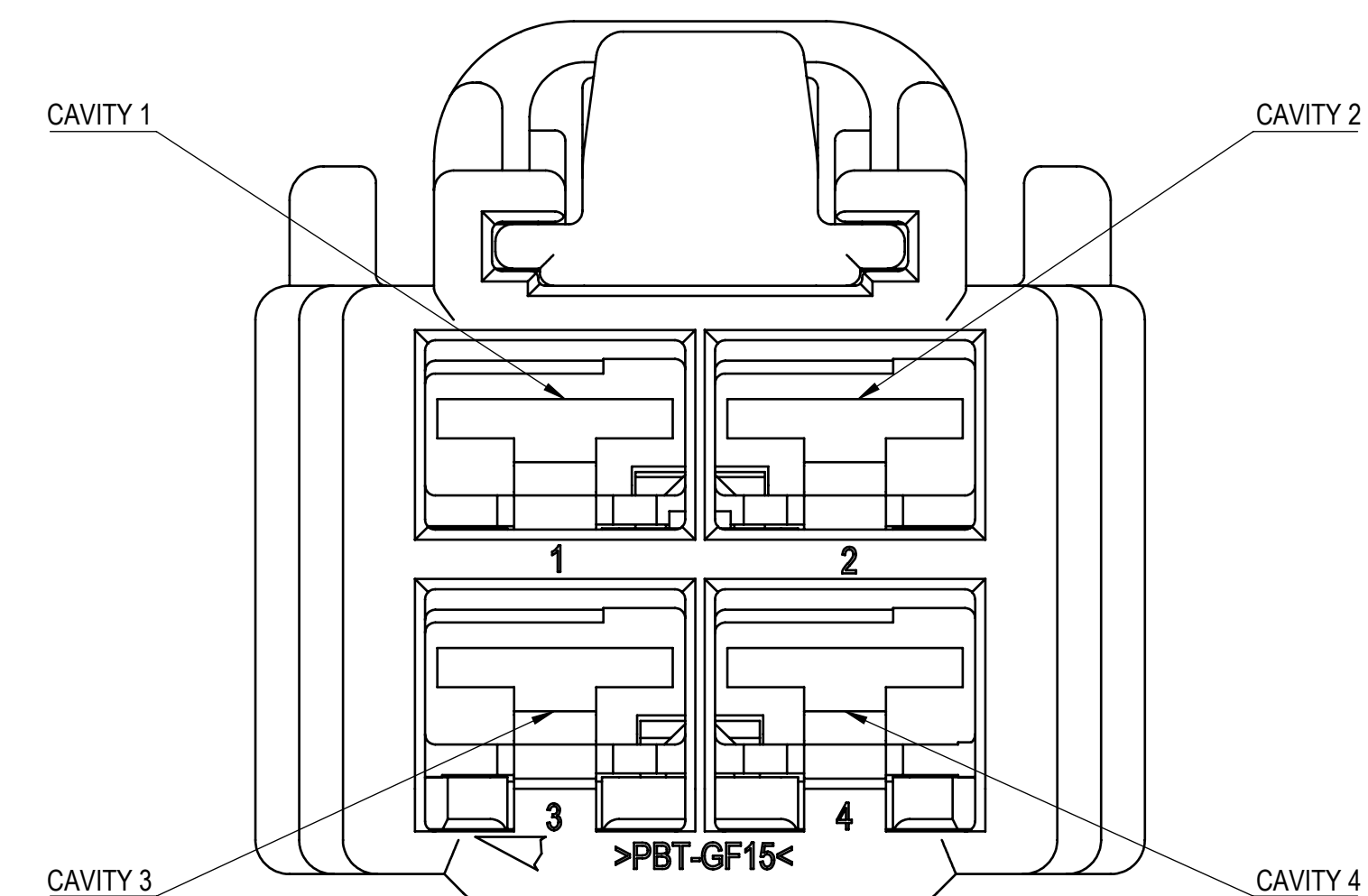
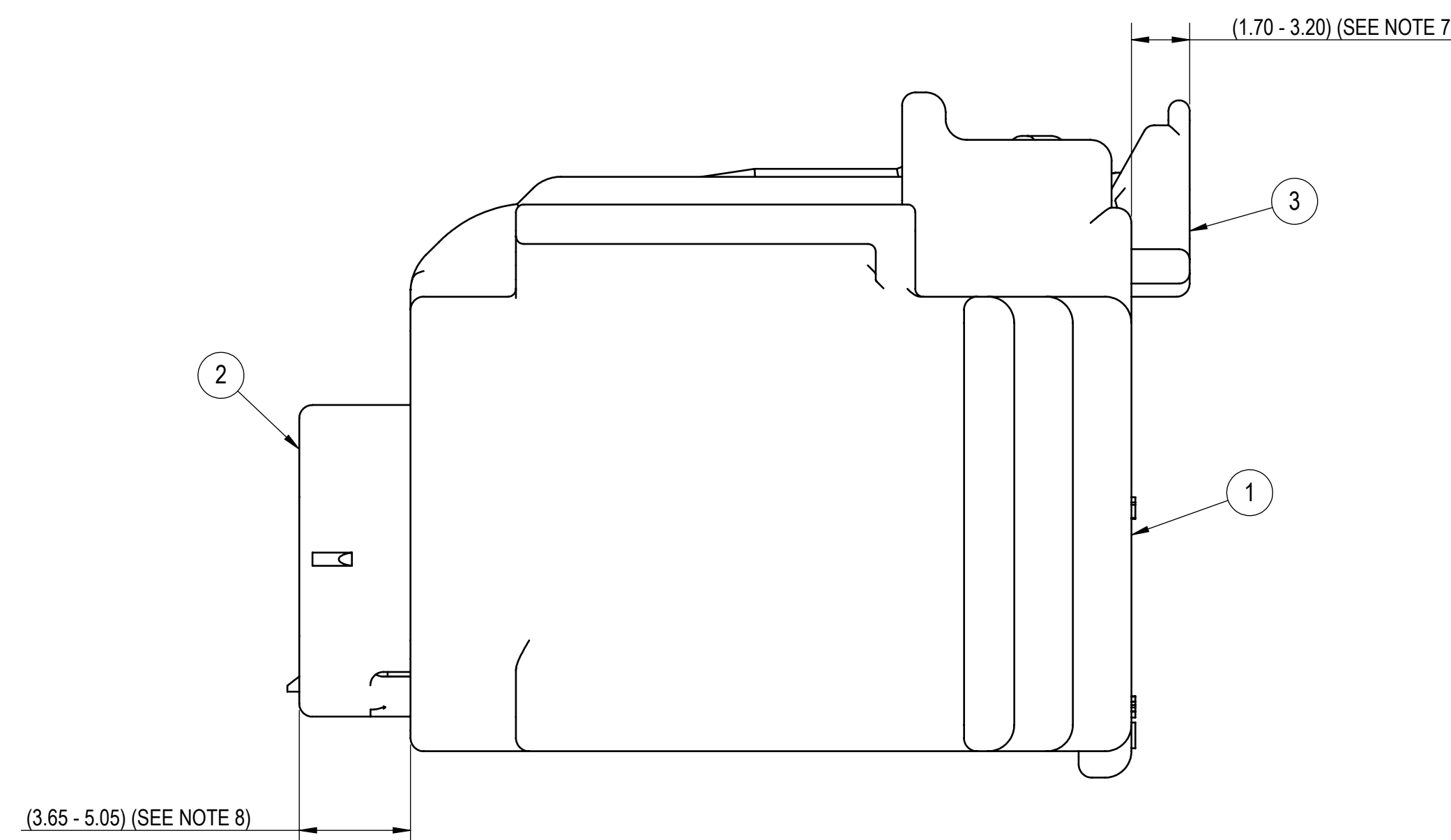
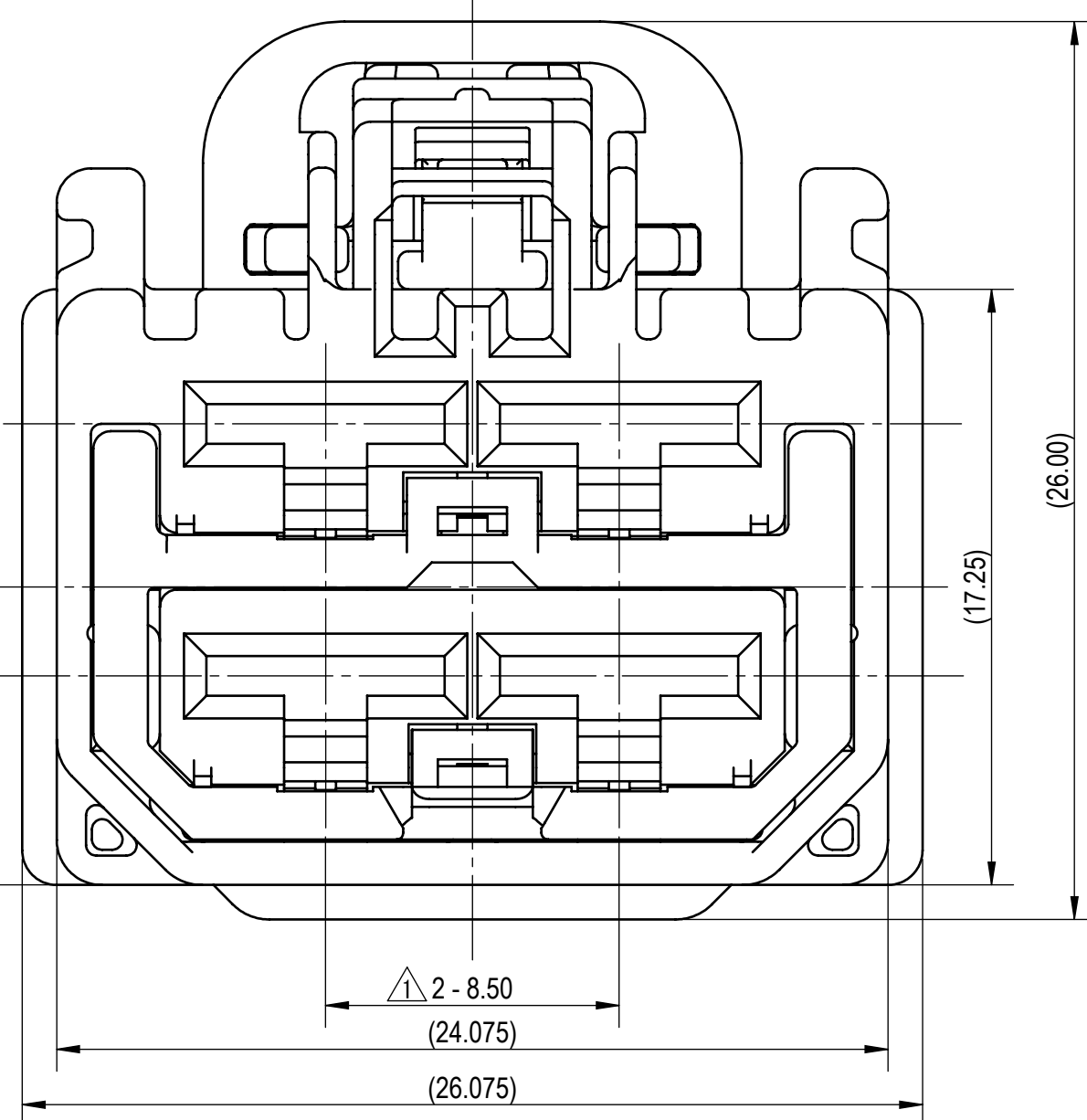
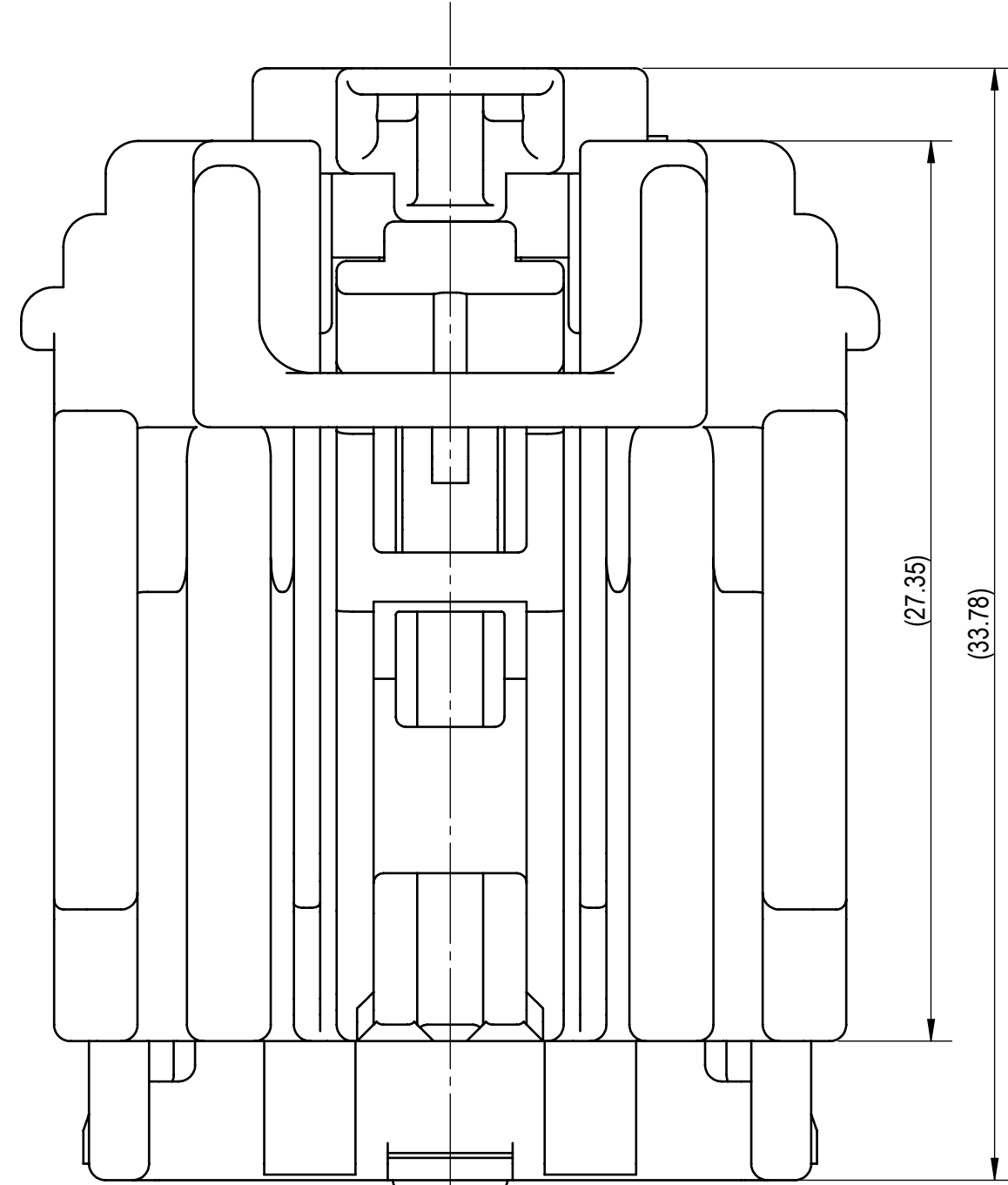

NOTES:

- PARTS MUST BE PURCHASED FROM YAZAKI.
- PARTS MUST BE FREE OF FLASH AND IMPERFECTIONS THAT AFFECT FUNCTION.
- APPLICABLE TERMINAL: SEE DRAWING 7116-4120-02-R (6.3 YESC UNSEALED)
MAX WIRE OD: 4.20mm
- MATING PART NUMBER: 7282-6469-40
- PART SATISFIES -GMW 3191 DATE JUNE 2012 (T2N1/S1/MF3)
PF 90012, REV.B, DATE APRIL 2017 (T2N1/S1/MF3)
- PART TO COMPLY WITH YPES-31-038 REQUIREMENTS.
- THIS DIMENSION SHOWS THE PRE-SET POSITION OF THE CPA.
- THIS DIMENSION SHOWS THE PRE-SET POSITION OF THE TPA.
- THIS DRAWING IS TO BE USED FOR INTERNAL YAZAKI PSW SUBMISSION.
- HANDLING MANUAL NUMBER: YPES-15-599E
- APPLICABLE WIRE COVER PART NUMBER: 7174-2216-30 & 7174-2215-30 (TWO PIECES COVER)

△	DATE	REVISION RECORD	NO.	CHKD
△	09-05-2022	UPDATED TO LATEST STANDARDS AND ADDED WIRE COVER INFORMATION	C22-A459	AC
-	09-17-2018	NEW	C18-A890	JG

GENERAL TOLERANCE											
	10MAX	50MAX	100MAX	250MAX	250OVR	R5 MAX	R10 MAX	R20 MAX	R20 OVR	ANGLE	ECCENT
A	±0.15	±0.2	±0.3	±0.5	±0.75					±3°	0.1
B	±0.2	±0.3	±0.55	±0.95	±1.4	±0.2	±0.3	±0.5	±2.5	±3°	0.15
Ⓒ	±0.3	±0.5	±0.8	±1.4	±2					±3°	0.15
	SPECIFIED										MASS (9.91) g

CUSTOMER	CUSTOMER PART NO.	CUSTOMER DWG NO.	MATL SPEC.	SEE TABLE	TREAT. & FIN.	N/A
OFFICE	YNA	TRIAL PART NO.	NAME	4P 6.3mm YESC KAIZEN UNSEALED FEMALE CONNECTOR SUB-ASSEMBLY		
VENDOR			PART NO.	7289-7459-40		
VENDOR NO.			CH. CODE	7289-7459-40:R		
			DWG NO.	7289-7459-40:R		
			YAZAKI CORPORATION			