

# Spezifikation für Freigabe / specification for release

Kunde / customer :  
 Artikelnummer / part number : **7490100110A**  
 Bezeichnung : **LAN-Übertrager WE-LAN**  
 description : **LAN-Transformer WE-LAN**



DATUM / DATE : 2015-01-26

## A Mechanische Abmessungen / dimensions :

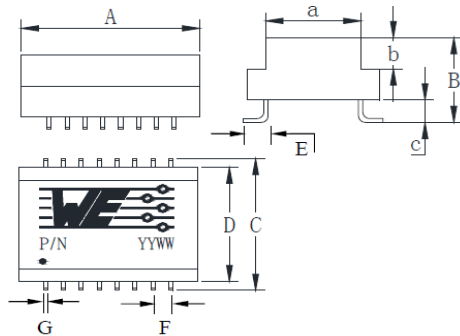

	10-100 BaseT	
A	12,70 ± 0,25	mm
B	6,35 max.	mm
C	9,40 ± 0,25	mm
D	8,80 ± 0,25	mm
E	1,20 ± 0,05	mm
F	1,27 ± 0,05	mm
G	0,30 ± 0,10	mm
a	6,80 ± 0,25	mm
b	2,40 ± 0,25	mm
c	1,55 max.	mm

● = Pin 1

## B Elektrische Eigenschaften / electrical properties :

Eigenschaften / properties	Testbedingungen / test conditions		Wert / value	Einheit / unit	tol.
Induktivität / Inductance	100kHz / 100mV @ 8mA DC-Bias	OCL	350	µH	min.
Übersetzungsverhältnis / Turns ratio	100kHz / 100mV	TR	1 : 1	Tx	3%
			1 : 1	Rx	
Insertion Loss	1-100MHz	IL	-1,1	dB	max.
Return Loss	1-30MHz @ 100Ω	RL	-18	dB	min.
	30-60MHz @ 100Ω		-14		
	60-80MHz @ 100Ω		-12		
	80-100MHz @ 100Ω		-10		
Differential to Common Mode Rejection	30MHz	DCMR	-38	dB	min.
	60MHz		-38		
	100MHz		-30		
Crosstalk	60MHz	CT	-40	dB	min.
	100MHz		-35		

## C Lötpad / soldering spec. :

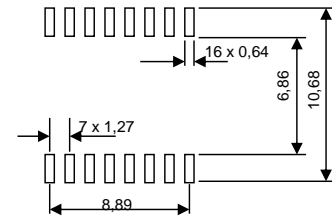

## D Prüfgeräte / test equipment :

HP-4284 CH-19073  
 HP-8714 CH-3250

## E Testbedingungen / test conditions :

Luftfeuchtigkeit / humidity: 33%  
 Umgebungstemperatur / temperature: +25°C

## F Werkstoffe & Zulassungen / material & approvals :

Basismaterial / base material: Ferrit/ ferrite  
 Draht / wire: 0UEW QPN200  
 Kontaktmaterial/ contact plating: Cu-Ni-Sn  
 Gehäuse/ case: Bakelite & UL94-V0

## G Eigenschaften / general specifications :

Betriebstemp. / operating temperature: -0°C - + 70°C  
 Hochspannungsprüfung / Hipot test: 1500Vrms 1min.  
 Geeignet für 10/100Base-TX gemäß IEEE 802.3u /  
 Coplanarität / Coplanarity: < 0,1 mm  
 Compliant with IEEE 802.3u for 10/100Base-TX-Applications  
 Auto MDIX fähig / Auto MDIX capable

Freigabe erteilt / general release:	<b>Kunde / customer</b>		
.....	.....		
Datum / date	Unterschrift / signature		
.....	<b>Würth Elektronik</b>		
.....	.....		
Geprüft / checked	Kontrolliert / approved		
.....	Name	Änderung / modification	Datum / date
	JaB	Revision 02	2015-01-26
	MLe	Revision 01	2014-01-03
	MLe	Revision 00	2012-11-09

### Würth Elektronik eiSos GmbH & Co.KG

D-74638 Waldenburg · Max-Eyth-Straße 1 - 3 · Germany · Telefon (+49) (0) 7942 - 945 - 0 · Telefax (+49) (0) 7942 - 945 - 400  
<http://www.we-online.com>

# Spezifikation für Freigabe / specification for release

Kunde / customer :  
 Artikelnummer / part number : **7490100110A**  
 Bezeichnung : **LAN-Übertrager WE-LAN**  
 description : **LAN-Transformer WE-LAN**



DATUM / DATE : 2015-01-26

## H Schaltbild / Schematics :

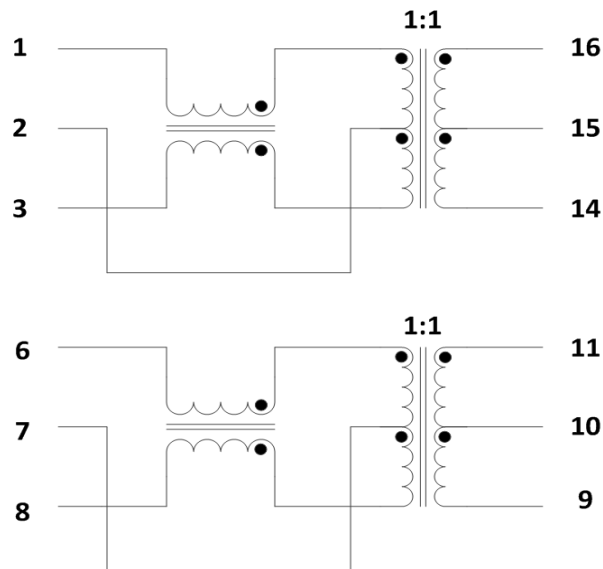

Freigabe erteilt / general release:	<b>Kunde / customer</b>			
.....	.....			
Datum / date	Unterschrift / signature			
	<b>Würth Elektronik</b>	JaB	Revision 02	2015-01-26
		MLe	Revision 01	2014-01-03
		MLe	Revision 00	2012-11-09
Geprüft / checked	Kontrolliert / approved	Name	Änderung / modification	Datum / date

### Würth Elektronik eiSos GmbH & Co.KG

D-74638 Waldenburg · Max-Eyth-Straße 1 - 3 · Germany · Telefon (+49) (0) 7942 - 945 - 0 · Telefax (+49) (0) 7942 - 945 - 400  
<http://www.we-online.com>