

Spezifikation für Freigabe / specification for release

Kunde / customer :
 Artikelnummer / part number : **7490220121**
 Bezeichnung : **LAN-Übertrager WE-LAN**
 description : **LAN-Transformer WE-LAN**



DATUM / DATE : 2018-09-10

A Mechanische Abmessungen / dimensions :

1000 BaseT 4PPoE

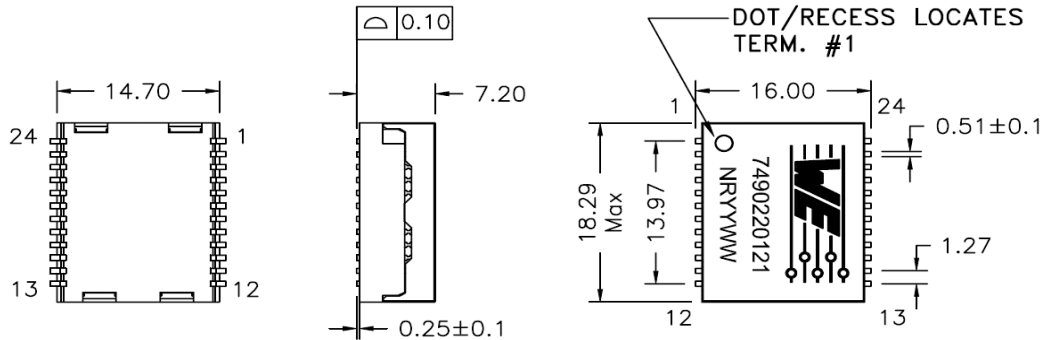

B Elektrische Eigenschaften / electrical properties :

Eigenschaften / properties	Testbedingungen / test conditions		Wert / value	Einheit / unit	tol.
Induktivität / Inductance	100kHz / 100mV @ 18mA DC-Bias	OCL	350	µH	min.
Übersetzungsverhältnis / Turns ratio	100kHz / 100mV	1CT:1CT	1 : 1	Tx	±2%
			1 : 1	Rx	
Insertion Loss	1-100MHz	IL	-1,0	dB	max.
Return Loss	1MHz - 30MHz	RL	-18	dB	min.
	30MHz - 60MHz		-14		
	60MHz - 80MHz		-12		
	80MHz - 100MHz		-10		
Common to Common Mode Rejection	1MHz - 30MHz	CMRR	-40	dB	min.
	30MHz - 60MHz		-35		
	60MHz - 100MHz		-30		
Crosstalk	1MHz - 60MHz	CT	-35	dB	min.
	60MHz - 100MHz		-30		

C Lötpad / soldering spec. :

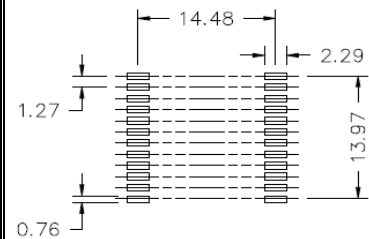

D Prüfgeräte / test equipment :

Agilent E5071C

E Testbedingungen / test conditions :

Luffeuchtigkeit / Humidity: 33%
 Umgebungstemperatur / Temperature: +25°C

F Werkstoffe & Zulassungen / material & approvals :

Basismaterial / Base material: Ferrit / Ferrite
 Draht / Wire: 0UEW/Y 180
 Kontaktmaterial / Contact plating: Cu-Ni-Sn
 Gehäuse / Case: DAP Black per UL 94V-0

G Eigenschaften / general specifications :

Betriebstemp. / Operating temperature: -40°C - +105°C
 Hochspannungsprüfung / Hipot test: 1500Vrms 1min.
 Geeignet für 1000BaseT gemäß kommendem IEEE 802.3bt /
 Compliant with upcoming IEEE 802.3bt for 4PPoE

Freigabe erteilt / general release:

Kunde / customer			
.....	JaB	Version 04
Datum / date	Unterschrift / signature	JaB	Version 03
Würth Elektronik		JaB	Version 02
		JaB	Version 01
.....	JaB	Preliminary
Geprüft / checked	Kontrolliert / approved	Name	Änderung / modification
			Datum / date

Würth Elektronik eiSos GmbH & Co.KG

D-74638 Waldenburg · Max-Eyth-Straße 1 - 3 · Germany · Telefon (+49) (0) 7942 - 945 - 0 · Telefax (+49) (0) 7942 - 945 - 400
<http://www.we-online.com>

Spezifikation für Freigabe / specification for release

Kunde / customer :
 Artikelnummer / part number : **7490220121**
 Bezeichnung : **LAN-Übertrager WE-LAN**
 description : **LAN-Transformer WE-LAN**



DATUM / DATE : 2018-09-10

H PoE Eigenschaften :

Designed für Anwendungen bis 600mA
 pro Mittelanzapfung
 Designed für 30W Anwendungen wenn zwei Kanäle bestromt
 Designed für 60W Anwendungen wenn vier Kanäle bestromt

H PoE Specifications :

Designed to support applications up to 600mA
 per centre tap
 Designed for 30W applications when using two channels
 Designed for 60W applications when using four channels

I Schaltbild / Schematics :

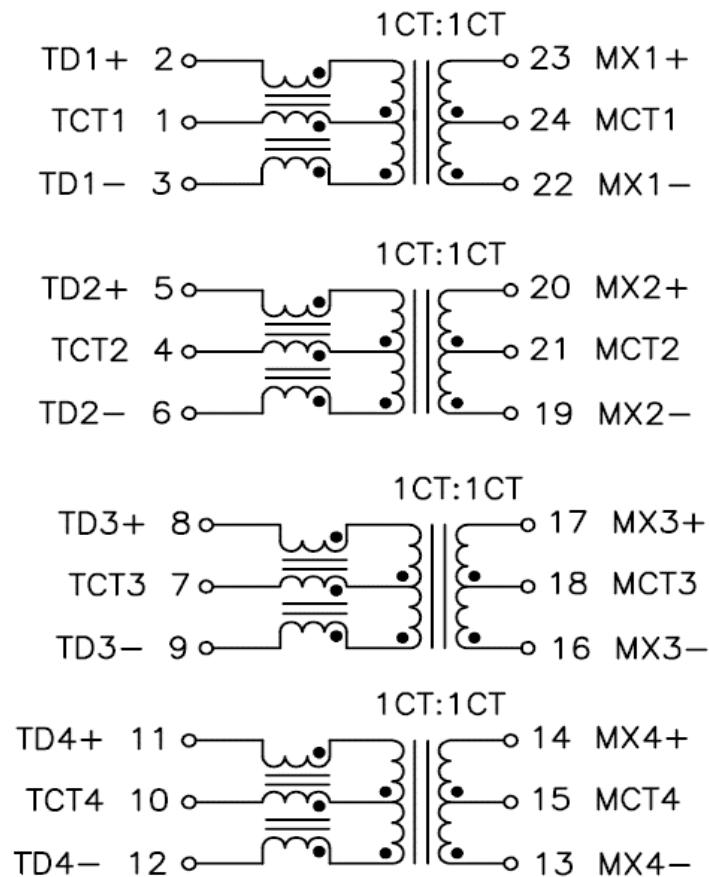

.....		
Datum / date	Unterschrift / signature	JaB	Version 04
	Würth Elektronik	JaB	Version 03
		JaB	Version 02
		JaB	Version 01
.....	JaB	Preliminary
Geprüft / checked	Kontrolliert / approved	Name	Änderung / modification
			Datum / date

Würth Elektronik eiSos GmbH & Co.KG

D-74638 Waldenburg · Max-Eyth-Straße 1 - 3 · Germany · Telefon (+49) (0) 7942 - 945 - 0 · Telefax (+49) (0) 7942 - 945 - 400
<http://www.we-online.com>