

## Low-voltage CMOS quad dual input NAND gate with 5 V tolerant inputs

Datasheet – production data

### Features

- 5 V tolerant inputs
- High speed
  - $t_{PD} = 4.3$  ns (max.) at  $V_{CC} = 3$  V
- Power-down protection on inputs and outputs
- Symmetrical output impedance
  - $|I_{OH}| = I_{OL} = 24$  mA (min.) at  $V_{CC} = 3$  V
- PCI bus levels guaranteed at 24 mA
- Balanced propagation delay
  - $t_{PLH} \cong t_{PHL}$
- Operating voltage range
  - $V_{CC}$  (opr.) = 2.0 V to 3.6 V
- Pin and function compatible with 74 series 00
- Latch-up performance exceeds 500 mA (JESD 17)
- ESD performance
  - HBM: 2000 V (MIL STD 883 method 3015)
  - MM: 200 V
  - CDM: 1000 V

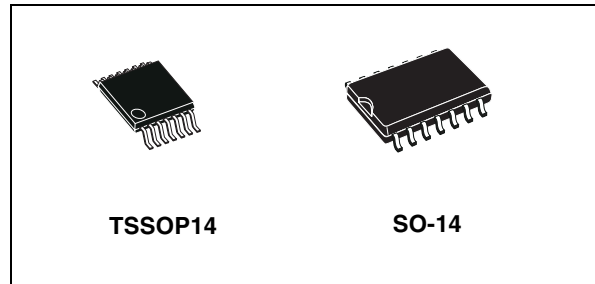

### Description

The 74LCX00 device is a low-voltage CMOS quad dual input NAND gate manufactured with sub-micron silicon gate and double layer metal wiring C<sup>2</sup>MOS technology. It is ideal for low-power and high-speed 3.3 V applications and can be interfaced to a 5 V signal environment for inputs.

It has the same speed performance at 3.3 V as the 5 V AC/ACT family, combined with lower power consumption.

All inputs and outputs are equipped with protection circuits against static discharge, giving them 2 kV ESD immunity and transient excess voltage.

### Applications

- Automotive
- Industrial
- Computer
- Consumer

**Table 1. Device summary**

Order code	Temperature range	Package	Packaging	Marking
74LCX00TTR	-40/+85 °C	TSSOP14	Tape and reel	LCX00
74LCX00YTTR <sup>(1)</sup>	-40/+85 °C	TSSOP14 (automotive grade)	Tape and reel	LCX00Y
74LCX00MTR	-40/+85 °C	SO-14	Tape and reel	74LCX00
74LCX00YMTR <sup>(1)</sup>	-40/+85 °C	SO-14 (automotive grade)	Tape and reel	74LCX00Y

1. Qualification and characterization according to AEC Q100 and Q003 or equivalent, advanced screening according to AEC Q001 and Q002 or equivalent.

# Contents

<b>1</b>	<b>Logic symbols and I/O equivalent circuit</b>	<b>3</b>
<b>2</b>	<b>Pin settings</b>	<b>4</b>
2.1	Pin connections	4
2.2	Pin description	4
2.3	Truth table	4
<b>3</b>	<b>Maximum ratings</b>	<b>5</b>
	Recommended operating conditions	5
<b>4</b>	<b>Electrical characteristics</b>	<b>6</b>
<b>5</b>	<b>Test circuit</b>	<b>8</b>
<b>6</b>	<b>Waveforms</b>	<b>9</b>
<b>7</b>	<b>Package mechanical data</b>	<b>10</b>
<b>8</b>	<b>Revision history</b>	<b>15</b>

# 1 Logic symbols and I/O equivalent circuit

Figure 1. IEC logic symbols

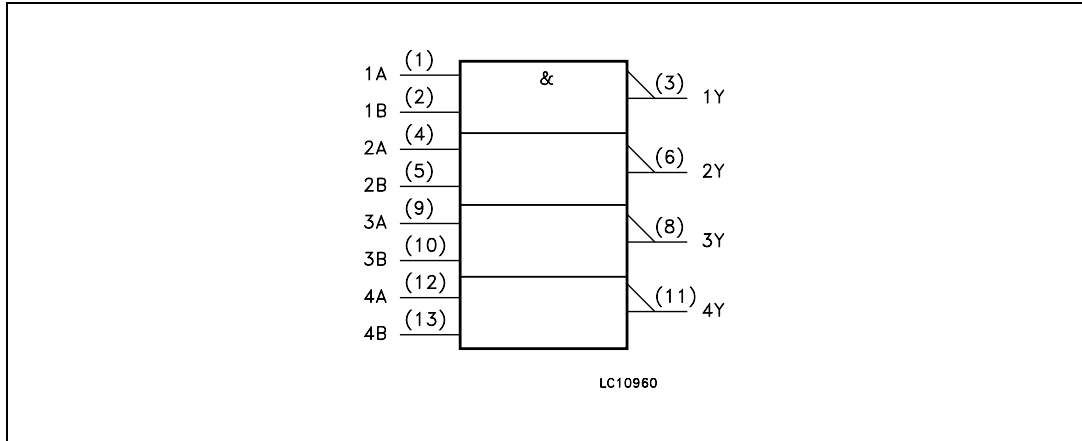
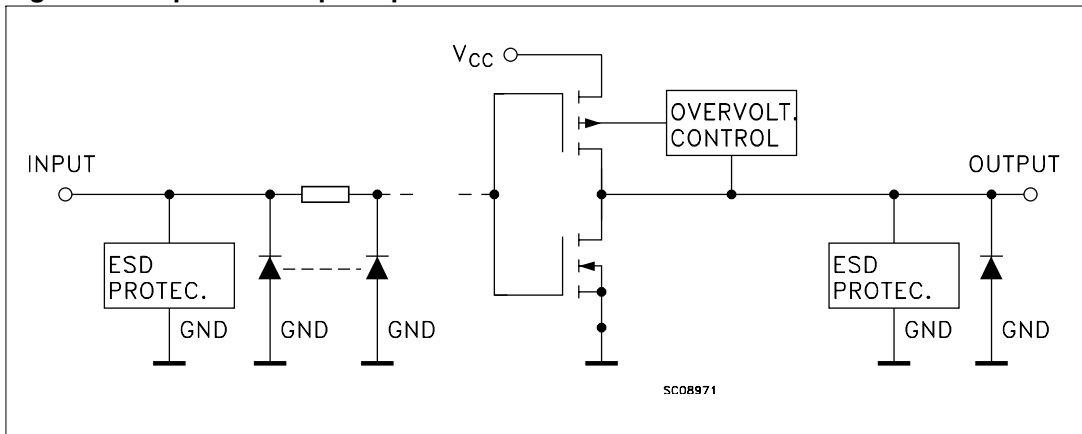

Figure 2. Input and output equivalent circuit



## 2 Pin settings

### 2.1 Pin connections

Figure 3. Pin connections (top through view)

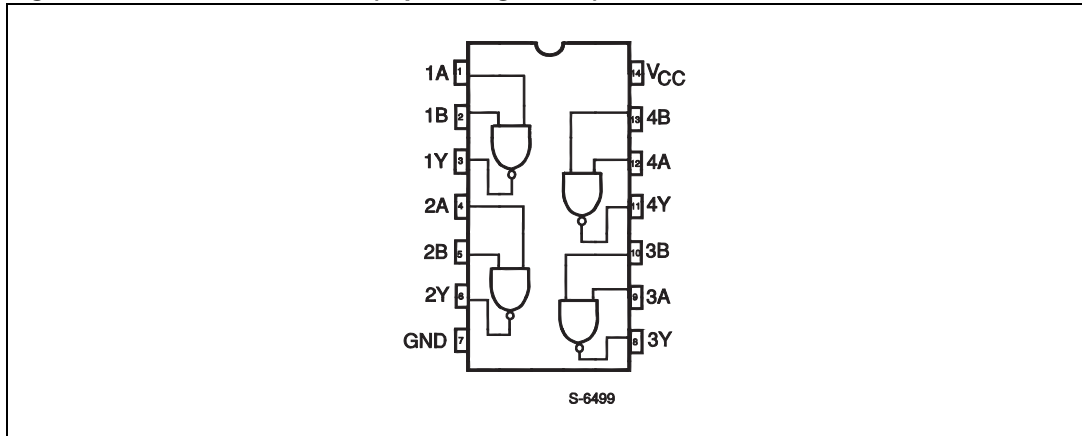

### 2.2 Pin description

Table 2. Pin description

Pin number	Symbol	Name and function
1, 4, 9, 12	1A to 4A	Data inputs
2, 5, 10, 13	1B to 4B	Data inputs
3, 6, 8, 11	1Y to 4Y	Data outputs
7	GND	Ground (0 V)
14	V <sub>CC</sub>	Positive supply voltage

### 2.3 Truth table

Table 3. Truth table

Inputs		Output
A	B	Y
L	L	H
L	H	H
H	L	H
H	H	L

### 3 Maximum ratings

Stressing the device above the rating listed in [Table 4: Absolute maximum ratings](#) may cause permanent damage to the device. These are stress ratings only and operation of the device at these or any other conditions above those indicated in [Table 5: Recommended operating conditions](#) of this specification is not implied. Exposure to absolute maximum rating conditions for extended periods may affect device reliability.

**Table 4. Absolute maximum ratings**

Symbol	Parameter	Value	Unit
V <sub>CC</sub>	Supply voltage	-0.5 to +7.0	V
V <sub>I</sub>	DC input voltage	-0.5 to +7.0	V
V <sub>O</sub>	DC output voltage (V <sub>CC</sub> = 0 V)	-0.5 to +7.0	V
V <sub>O</sub>	DC output voltage (high or low state) <sup>(1)</sup>	-0.5 to V <sub>CC</sub> + 0.5	V
I <sub>IK</sub>	DC input diode current	-50	mA
I <sub>OK</sub>	DC output diode current <sup>(2)</sup>	-50	mA
I <sub>O</sub>	DC output current	±50	mA
I <sub>CC</sub>	DC supply current per supply pin	±100	mA
I <sub>GND</sub>	DC ground current per supply pin	±100	mA
T <sub>stg</sub>	Storage temperature	-65 to +150	°C
T <sub>L</sub>	Lead temperature (10 sec.)	300	°C

1. I<sub>O</sub> absolute maximum rating must be observed.

2. V<sub>O</sub> < GND.

### Recommended operating conditions

**Table 5. Recommended operating conditions**

Symbol	Parameter	Value	Unit
V <sub>CC</sub>	Supply voltage <sup>(1)</sup>	2.0 to 3.6	V
V <sub>I</sub>	Input voltage	0 to 5.5	V
V <sub>O</sub>	Output voltage (V <sub>CC</sub> = 0 V)	0 to 5.5	V
V <sub>O</sub>	Output voltage (high or low state)	0 to V <sub>CC</sub>	V
I <sub>OH</sub> , I <sub>OL</sub>	High or low level output current (V <sub>CC</sub> = 3.0 to 3.6 V)	±24	mA
I <sub>OH</sub> , I <sub>OL</sub>	High or low level output current (V <sub>CC</sub> = 2.7 V)	±12	mA
dt/dv	Input rise and fall time <sup>(2)</sup>	0 to 10	ns/V

1. Truth table guaranteed: 1.5 V to 3.6 V.

2. V<sub>IN</sub> from 0.8 V to 2 V at V<sub>CC</sub> = 3.0 V.

## 4 Electrical characteristics

**Table 6. DC specifications**

Symbol	Parameter	Test condition		Value		Unit
		V <sub>CC</sub> (V)		-40 to 85 °C		
				Min.	Max.	
V <sub>IH</sub>	High level input voltage	2.7 to 3.6		2.0		V
V <sub>IL</sub>	Low level input voltage					0.8
V <sub>OH</sub>	High level output voltage	2.7 to 3.6	I <sub>O</sub> = -100 μA	V <sub>CC</sub> - 0.2		V
		2.7	I <sub>O</sub> = -12 mA	2.2		
		3.0	I <sub>O</sub> = -18 mA	2.4		
			I <sub>O</sub> = -24 mA	2.2		
V <sub>OL</sub>	Low level output voltage	2.7 to 3.6	I <sub>O</sub> = 100 μA		0.2	V
		2.7	I <sub>O</sub> = 12 mA		0.4	
		3.0	I <sub>O</sub> = 16 mA		0.4	
			I <sub>O</sub> = 24 mA		0.55	
I <sub>I</sub>	Input leakage current	2.7 to 3.6	V <sub>I</sub> = 0 to 5.5 V		±5	μA
I <sub>off</sub>	Power OFF leakage current	0	V <sub>I</sub> or V <sub>O</sub> = 5.5 V		10	μA
I <sub>CC</sub>	Quiescent supply current	2.7 to 3.6	V <sub>I</sub> = V <sub>CC</sub> or GND		10	μA
			V <sub>I</sub> or V <sub>O</sub> = 3.6 to 5.5 V		±10	
ΔI <sub>CC</sub>	I <sub>CC</sub> incr. per input	2.7 to 3.6	V <sub>IH</sub> = V <sub>CC</sub> - 0.6 V		500	μA

**Table 7. Dynamic switching characteristics**

Symbol	Parameter	Test condition		Value			Unit
		V <sub>CC</sub> (V)		T <sub>A</sub> = 25 °C			
				Min.	Typ.	Max.	
V <sub>OLP</sub>	Dynamic low level quiet output <sup>(1)</sup>	3.3	C <sub>L</sub> = 50 pF V <sub>IL</sub> = 0 V, V <sub>IH</sub> = 3.3 V		0.8		V
V <sub>OLV</sub>					-0.8		

1. Number of outputs defined as “n”. Measured with “n-1” outputs switching from HIGH to LOW or LOW to HIGH. The remaining output is measured in the LOW state.

**Table 8. AC electrical characteristics**

Symbol	Parameter	Test condition				Value		Unit
		V <sub>CC</sub> (V)	C <sub>L</sub> (pF)	R <sub>L</sub> (Ω)	t <sub>s</sub> = t <sub>r</sub> (ns)	-40 to 85 °C		
						Min.	Max.	
t <sub>PLH</sub> t <sub>PHL</sub>	Propagation delay time	2.7	50	500	2.5		5.1	ns
		3.0 to 3.6				1.0	4.3	
t <sub>OSLH</sub> t <sub>OSHL</sub>	Output-to-output skew time <sup>(1), (2)</sup>	3.0 to 3.6	50	500	2.5		1.0	ns

- Skew is defined as the absolute value of the difference between the actual propagation delay for any two outputs of the same device switching in the same direction, either HIGH or LOW (t<sub>OSLH</sub> = |t<sub>PLHm</sub> - t<sub>PLHn</sub>|, t<sub>OSHL</sub> = |t<sub>PHLm</sub> - t<sub>PHLn</sub>|).
- Parameter guaranteed by design.

**Table 9. Capacitive characteristics**

Symbol	Parameter	Test condition		Value			Unit
		V <sub>CC</sub> (V)		T <sub>A</sub> = 25 °C			
				Min.	Typ.	Max.	
C <sub>IN</sub>	Input capacitance	3.3	V <sub>IN</sub> = 0 to V <sub>CC</sub>		6		pF
C <sub>PD</sub>	Power dissipation capacitance <sup>(1)</sup>	3.3	f <sub>IN</sub> = 10 MHz V <sub>IN</sub> = 0 or V <sub>CC</sub>		35		pF

- C<sub>PD</sub> is defined as the value of the IC's internal equivalent capacitance which is calculated from the operating current consumption without load. (Refer to [Section 5: Test circuit](#)). Average operating current can be obtained by the following equation. I<sub>CC(opr)</sub> = C<sub>PD</sub> × V<sub>CC</sub> × f<sub>IN</sub> + I<sub>CC</sub>/4 (per gate).

## 5 Test circuit

Figure 4. Test circuit

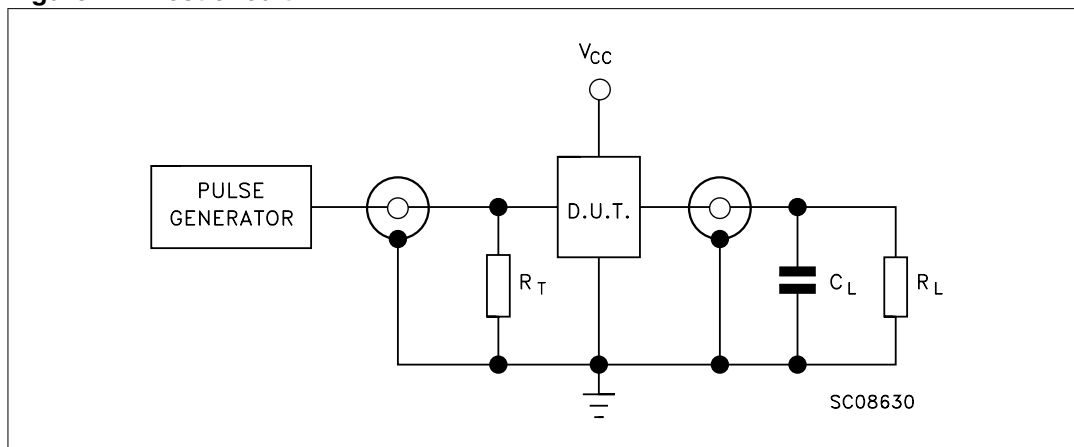

Note:  $C_L = 50 \text{ pF}$  or equivalent (includes jig and probe capacitance)  
 $R_L = 500 \Omega$  or equivalent  
 $R_T = Z_{OUT}$  of pulse generator (typically  $50 \Omega$ ).



## 6 Waveforms

Figure 5. Waveform - propagation delay ( $f = 1 \text{ MHz}$ ; 50% duty cycle)

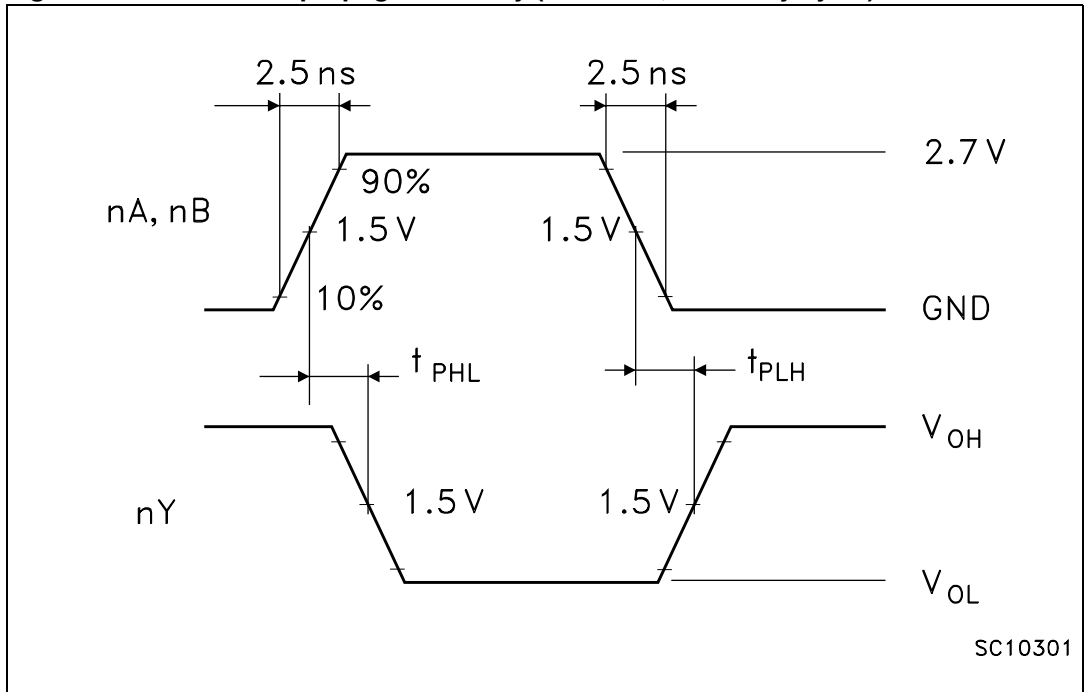

## 7 Package mechanical data

In order to meet environmental requirements, ST offers these devices in different grades of ECOPACK® packages, depending on their level of environmental compliance. ECOPACK specifications, grade definitions and product status are available at: [www.st.com](http://www.st.com). ECOPACK is an ST trademark.

Figure 6. SO-14 package outline

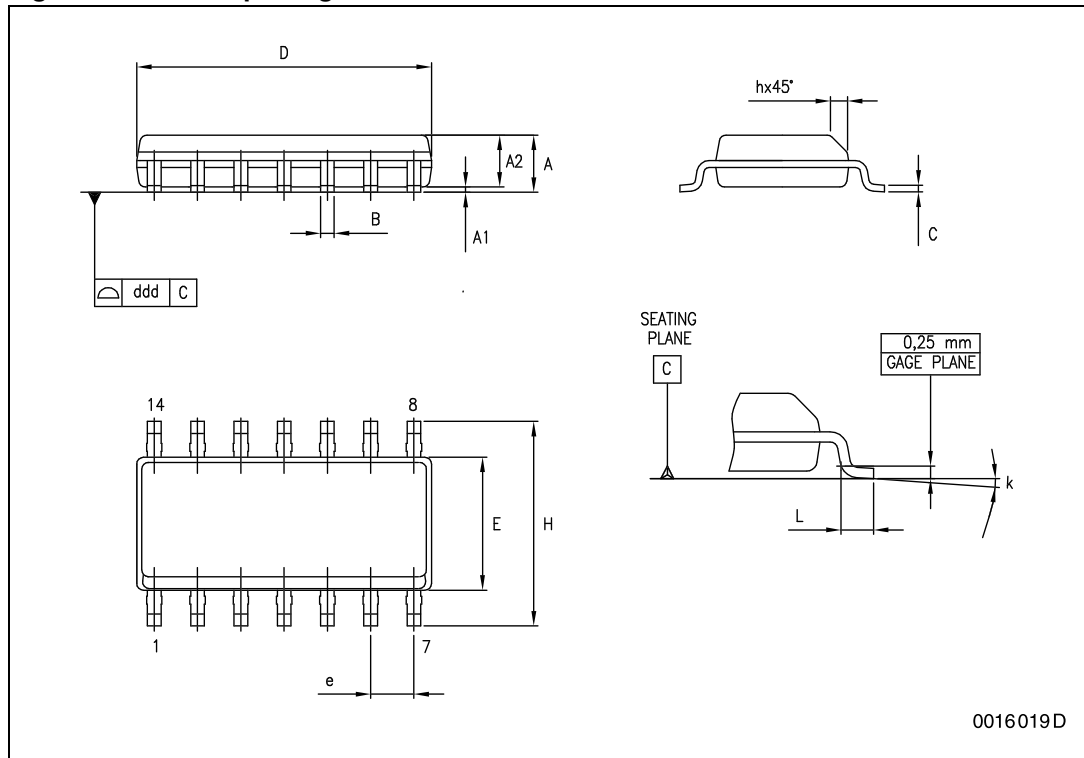

Table 10. SO-14 package mechanical data

Symbol	Dimensions					
	mm			inch		
	Min.	Typ.	Max.	Min.	Typ.	Max.
A	1.35		1.75	0.053		0.069
A1	0.1		0.25	0.004		0.010
A2	1.10		1.65	0.043		0.065
B	0.33		0.51	0.013		0.020
C	0.19		0.25	0.007		0.010
D	8.55		8.75	0.337		0.344
E	3.8		4.0	0.150		0.157
e		1.27			0.050	
H	5.8		6.2	0.228		0.244
h	0.25		0.50	0.010		0.020
L	0.4		1.27	0.016		0.050
k	0°		8°	0°		8°
ddd			0.100			0.004

Figure 7. TSSOP14 package outline

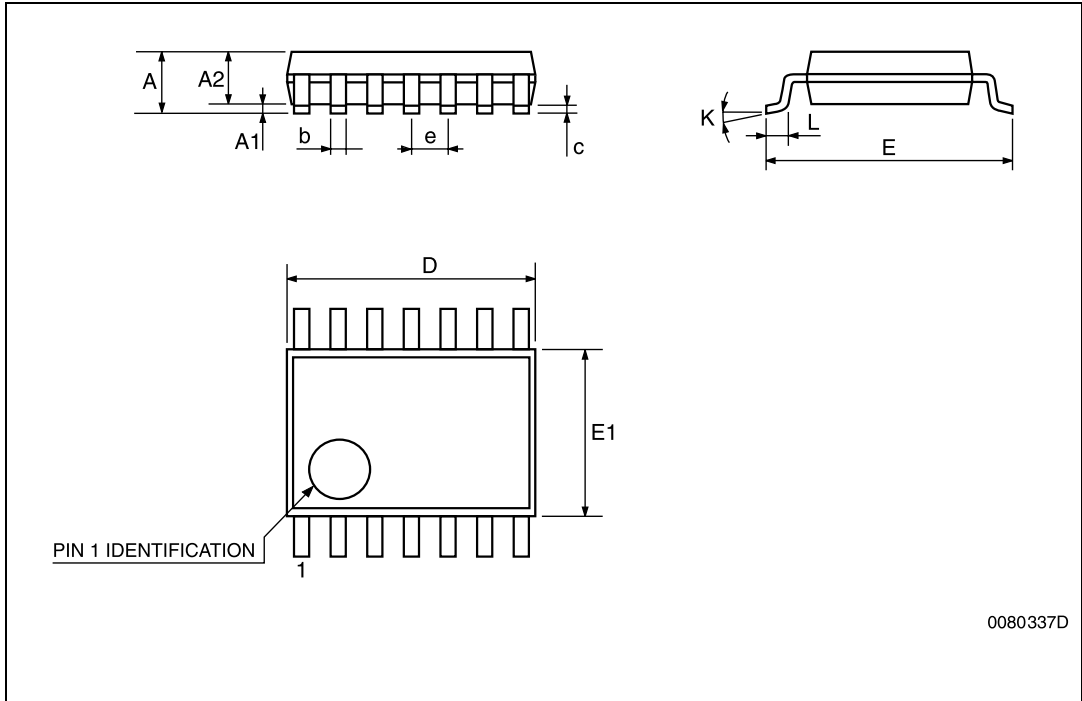
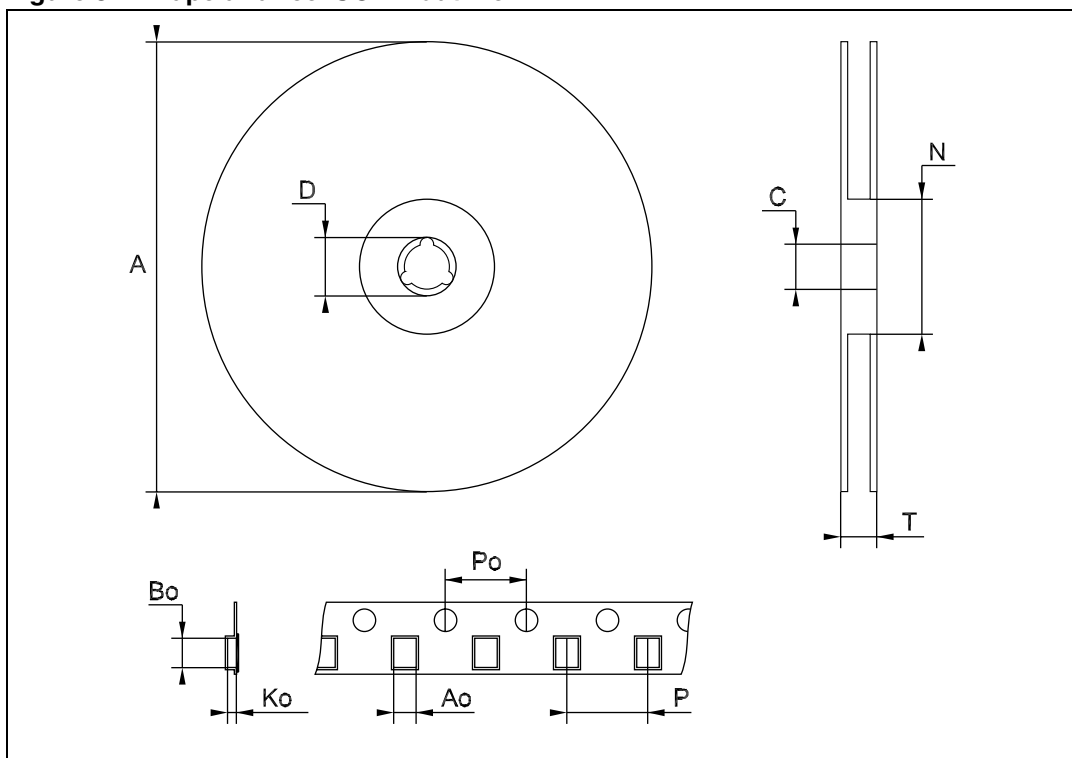

Table 11. TSSOP14 package mechanical data

Symbol	Dimensions					
	mm			inch		
	Min.	Typ.	Max.	Min.	Typ.	Max.
A			1.2			0.047
A1	0.05		0.15	0.002	0.004	0.006
A2	0.8	1	1.05	0.031	0.039	0.041
b	0.19		0.30	0.007		0.012
c	0.09		0.20	0.004		0.0089
D	4.9	5	5.1	0.193	0.197	0.201
E	6.2	6.4	6.6	0.244	0.252	0.260
E1	4.3	4.4	4.48	0.169	0.173	0.176
e		0.65 BSC			0.0256 BSC	
K	0°		8°	0°		8°
L	0.45	0.60	0.75	0.018	0.024	0.030

Figure 8. Tape and reel SO-14 outline



1. Drawing is not in scale.

Table 12. Tape and reel SO-14 mechanical data

Symbol	Dimensions					
	mm			inch		
	Min.	Typ.	Max.	Min.	Typ.	Max.
A			330			12.992
C	12.8		13.2	0.504		0.519
D	20.2			0.795		
N	60			2.362		
T			22.4			0.882
Ao	6.4		6.6	0.252		0.260
Bo	9		9.2	0.354		0.362
Ko	2.1		2.3	0.082		0.090
Po	3.9		4.1	0.153		0.161
P	7.9		8.1	0.311		0.319

Figure 9. Tape and reel TSSOP14 outline

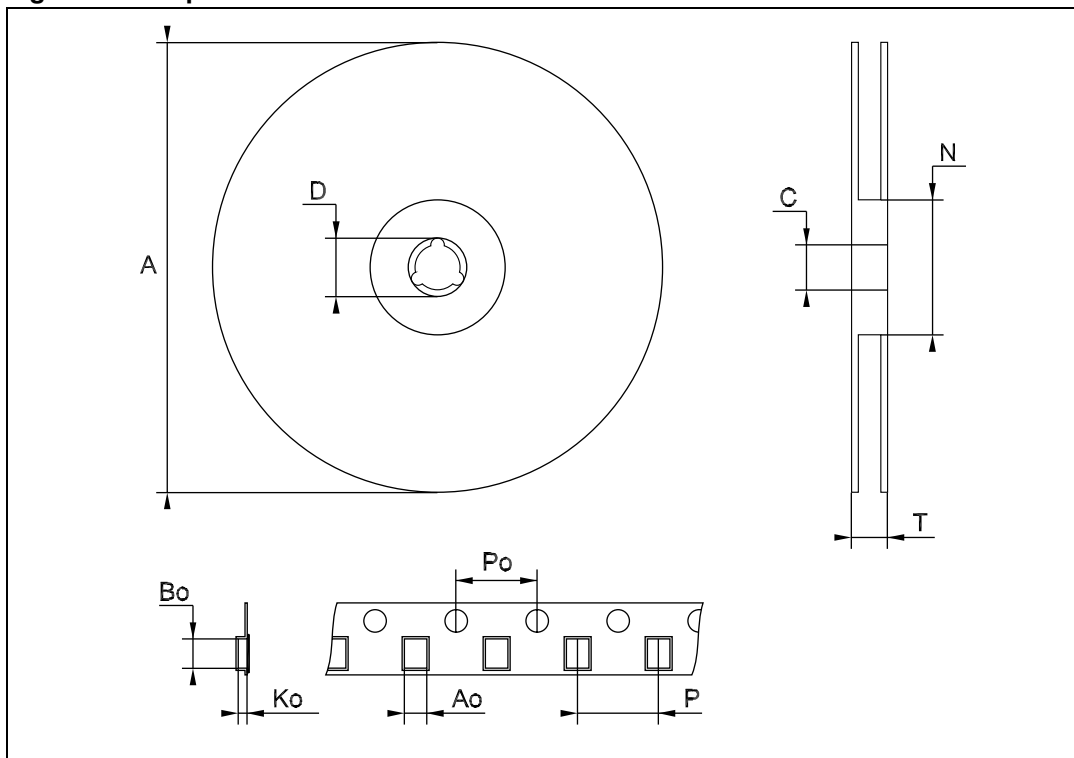

Drawing is not in scale.

Table 13. Tape and reel TSSOP14 mechanical data

Symbol	Dimensions					
	mm			inch		
	Min.	Typ.	Max.	Min.	Typ.	Max.
A			330			12.992
C	12.8		13.2	0.504		0.519
D	20.2			0.795		
N	60			2.362		
T			22.4			0.882
Ao	6.7		6.9	0.264		0.272
Bo	5.3		5.5	0.209		0.217
Ko	1.6		1.8	0.063		0.071
Po	3.9		4.1	0.153		0.161
P	7.9		8.1	0.311		0.319

## 8 Revision history

**Table 14. Document revision history**

Date	Revision	Changes
15-Sep-2004	4	Ordering code revision - pag 1
07-Jul-2006	5	New template, temperature ranges updated
20-Jun-2012	6	Added <a href="#">Applications on page 1</a> Updated <a href="#">Table 1: Device summary on page 1</a> Updated T <sub>op</sub> in <a href="#">Table 5: Recommended operating conditions</a> Updated ECOPACK® text in <a href="#">Section 7: Package mechanical data</a> Minor textual updates
02-Oct-2012	7	Updated ESD performance in <a href="#">Features</a> (updated HBM and MM, added CDM). Added 74LCX00YMTR device and "Marking" to <a href="#">Table 1</a> , updated temperature range, note <a href="#">1</a> . Updated <a href="#">Section 3: Maximum ratings</a> (added cross-references). Removed "Operating temperature" from <a href="#">Table 5</a> . Reformatted <a href="#">Section 7: Package mechanical data</a> . Minor corrections throughout document.