

**DUAL BIT DUAL POWER SUPPLY TRANSLATING
TRANSCEIVER WITH 3 STATE OUTPUTS**

Description

The 74LVCH2T45 is a dual-bit, dual-supply transceiver with tri-state outputs suitable for transmitting two logic bits across different voltage domains. The direction pin (DIR) and Port A, consisting of pins 1A and 2A, have logic levels in relation to $V_{CC}(A)$ while port B, consisting of pins 1B and 2B have logic levels related to $V_{CC}(B)$. This arrangement allows for universal low-voltage translation between any voltages from 1.2V to 5.5V. When a HIGH logic level is applied to the direction pin, port A pins become inputs and port B pins are outputs. Conversely, the roles of the ports are reversed when the direction pin is asserted LOW.

The tri-state (Ioff) feature places all port pins in a high impedance state when either power supply is at 0V, which prevents and damages backflow currents and provides power-down electrical isolation up to 5.5V as not to interfere with any logic activity on either of the ports.

The 74LVCH2T45 is a variant of the 74LVC2T45 that includes a bus hold feature at each input. The bus hold feature maintains the previous logic level therefore a valid logic level is always present eliminating the need for additional resistors for unused or disconnected inputs.

Features

- Wide Supply Voltage Range:
 - $V_{CC}(A)$: from 1.2V to 5.5V
 - $V_{CC}(B)$: from 1.2V to 5.5V
- ± 24 mA Output Drive at 3.3V
- CMOS Low Power Consumption 16 μ A Maximum I_{CC}
- High Noise Immunity
- I_{OFF} Supports Partial-Power-Down Mode Operation
- I_{OFF} Controlled by Either V_{CC} Being at 0V
- Inputs Accept up to 5.5V
- Maximum data rates:
 - 420Mbps (3.3V to 5V translation)
 - 210Mbps (translate to 3.3V)
 - 140Mbps (translate to 2.5V)
 - 75Mbps (translate to 1.8V)
 - 60Mbps (translate to 1.5V)
- ESD Protection Exceeds JESD 22
 - 4000-V Human Body Model (A114)
 - 1000 V Charged Device Model (C101)
- Latch-up Exceeds 100mA per JESD 78, Class I
- Specified from -40°C to +85°C and -40°C to +125°C
- **Totally Lead-Free & Fully RoHS Compliant (Notes 1 & 2)**
- **Halogen and Antimony Free. "Green" Device (Note 3)**
- **For automotive applications requiring specific change control (i.e. parts qualified to AEC-Q100/101/200, PPAP capable, and manufactured in IATF 16949 certified facilities), please [contact us](mailto:contact@diodes.com) or your local Diodes representative. <https://www.diodes.com/quality/product-definitions/>**

Notes: 1. No purposely added lead. Fully EU Directive 2002/95/EC (RoHS), 2011/65/EU (RoHS 2) & 2015/863/EU (RoHS 3) compliant.
 2. See <https://www.diodes.com/quality/lead-free/> for more information about Diodes Incorporated's definitions of Halogen- and Antimony-free, "Green" and Lead-free.
 3. Halogen- and Antimony-free "Green" products are defined as those which contain <900ppm bromine, <900ppm chlorine (<1500ppm total Br + Cl) and <1000ppm antimony compounds.

Pin Assignments

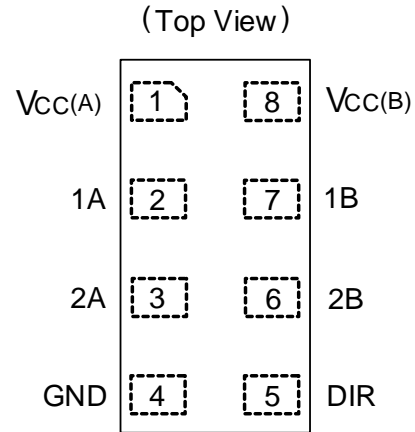

X2-DFN1210-8
X2-DFN1410-8

Applications

- Voltage Level Translation
Well-Suited to Join Logic Types Operating at Different Voltages
- Power-Down Signal Isolation
If Either Voltage Domain is Turned Off the Signal is Isolated and There is No Loading on Signal Lines
- Wide Array of Products, such as:
 - Cell Phones, Tablets, E-Readers
 - PCs, Notebooks, Netbooks, Ultrabooks
 - Networking, Routers, Gateways
 - Computer Peripherals, Hard Drives, CD/DVD ROM
 - TV, DVD, DVR, Set-Top Box
 - Personal Navigation / GPS
 - MP3 Players, Cameras, Video Recorders

Pin Descriptions

Pin Name	Pin	Function
VCC(A)	1	Supply for I/O Pin A; Reference for DIR
1A	2	Data Input/Output
2A	3	Data Input/Output
GND	4	Ground
DIR	5	Direction Control
2B	6	Data Input/Output
1B	7	Data Input/Output
VCC(B)	8	Supply for I/O Pin B

Logic Diagram

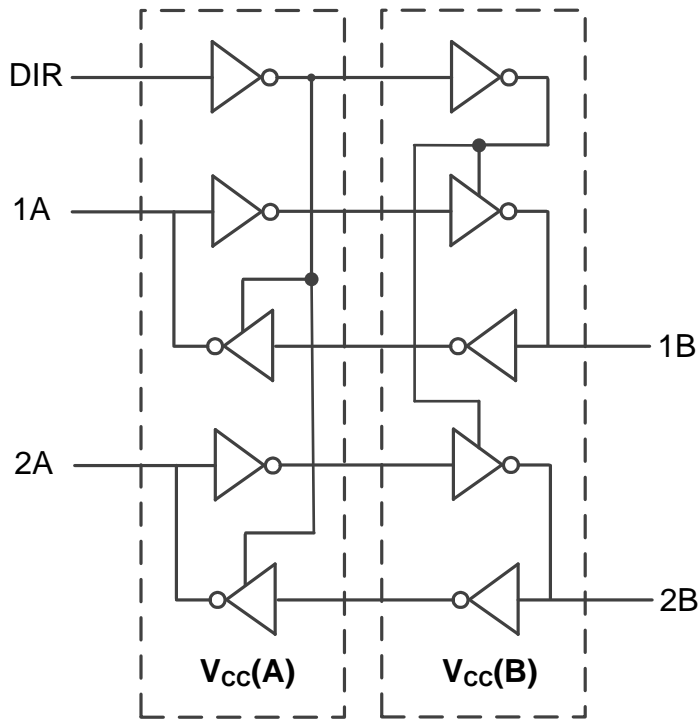

Function Tables

Input DIR (Direction Pin)	Operation
L	B Data to A Output
H	A Data to B Output

Inputs			Outputs	
A	B	DIR	A	B
Note 4	L	L	L	Note 4
Note 4	H	L	H	Note 4
L	Note 4	H	Note 4	L
H	Note 4	H	Note 4	H

Note: 4. Pin condition not applicable as defined by DIR.

Absolute Maximum Ratings (Note 5) (@ $T_A = +25^\circ\text{C}$, unless otherwise specified.)

Symbol	Parameter	Rating	Unit	
ESD HBM	Human Body Model ESD Protection	4	kV	
ESD CDM	Charged Device Model ESD Protection	1	kV	
$V_{CC(A)}, V_{CC(B)}$	Supply Voltage Range	-0.5 to +6.5	V	
V_I	Input Voltage Range	-0.5 to +6.5	V	
V_O	Voltage Applied to Output in High Impedance or I _{OFF} State	-0.5 to +6.5	V	
V_O	Voltage Applied to Output in High or Low State	A Pin	-0.3 to $V_{CC(A)} + 0.5$	V
		B Pin	-0.3 to $V_{CC(B)} + 0.5$	V
I_{IK}	Input Clamp Current $V_I < 0$	-50	mA	
I_{OK}	Output Clamp Current	-50	mA	
I_O	Continuous Output Current	± 50	mA	
—	Continuous Current Through V_{CC} or GND	± 100	mA	
T_J	Operating Junction Temperature	-40 to +150	$^\circ\text{C}$	
T_{STG}	Storage Temperature	-65 to +150	$^\circ\text{C}$	

Note: 5. Stresses beyond the absolute maximum can result in immediate failure or reduced reliability. These are stress values and device operation should be within recommend values.

Recommended Operating Conditions (Note 6) (@ $T_A = +25^\circ\text{C}$, unless otherwise specified.)

Symbol	Parameter	Conditions	Min	Max	Unit
$V_{CC(A)}$	Supply Voltage A	—	1.2	5.5	V
$V_{CC(B)}$	Supply Voltage B	—	1.2	5.5	V
V_I	Input Voltage	—	0	5.5	V
V_O	Output Voltage	Active Mode (Note 6)	0	V_{CCO}	V
		Suspend or 3-State Mode	0	5.5	V
T_A	Ambient Temperature	—	-40	+125	$^\circ\text{C}$
$\Delta t/\Delta V$	Input Transition Rise and Fall Rate	$V_{CCI} = 1.2\text{V}$ (Note 7)	—	20	ns/V
		$V_{CCI} = 1.4\text{V}$ to 1.95V	—	20	ns/V
		$V_{CCI} = 2.3\text{V}$ to 2.7V	—	20	ns/V
		$V_{CCI} = 3\text{V}$ to 3.6V	—	10	ns/V
		$V_{CCI} = 4.5\text{V}$ to 5.5V	—	5	ns/V

Notes: 6. V_{CCO} is the supply voltage associated with the output port.

7. V_{CCI} is the supply voltage associated with the input port.

Electrical Characteristics (@T_A = +25°C.)

Symbol	Parameter	Conditions	Min	Typ	Max	Unit
V _{OH}	HIGH-Level Output Voltage	V _I = V _{IH} or V _{IL} ; I _O = -3mA; V _{CCO} = 1.2V	—	1.09	—	V
V _{OL}	LOW-Level Output Voltage	V _I = V _{IH} or V _{IL} ; I _O = 3 mA; V _{CCO} = 1.2V	—	0.07	—	V
I _I	Input Leakage Current	DIR Input; V _I = 0V to 5.5V; V _{CC1} = 1.2V to 5.5V	—	—	±1	μA
I _{BHL}	Bus Hold LOW Current	A or B Port; V _I = 0.42V; V _{CC1} = 1.2V	—	19	—	μA
I _{BHH}	Bus Hold HIGH Current	A or B Port; V _I = 0.78V; V _{CC1} = 1.2V	—	19	—	μA
I _{BHLO}	Bus Hold LOW Overdrive Current	A or B Port; V _{CC1} = 1.2V	—	19	—	μA
I _{BHHO}	Bus Hold HIGH Overdrive Current	A or B Port; V _{CC1} = 1.2V	—	19	—	μA
I _{OZ}	OFF-State Output Current	A or B Port; V _O = 0V or V _{CCO} ; V _{CCO} = 1.2V to 5.5V	—	—	±1	μA
I _{OFF}	Power-Off Leakage Current	A Port; V _I or V _O = 0V to 5.5V; V _{CC(A)} = 0V; V _{CC(B)} = 1.2V to 5.5V	—	—	±1	μA
		B Port; V _I or V _O = 0V to 5.5V; V _{CC(B)} = 0V; V _{CC(A)} = 1.2V to 5.5V	—	—	±1	μA
C _I	Input Capacitance	DIR Input; V _I = 0V or 3.3V; V _{CC(A)} = V _{CC(B)} = 3.3V	—	2.2	—	pF
C _{I/O}	Input/Output Capacitance	A and B Port; Suspend Mode; V _O = 3.3V or 0V; V _{CC(A)} = V _{CC(B)} = 3.3V	—	6.0	—	pF

Electrical Characteristics (continued) (@T_A = +25°C.)

Symbol	Parameter	Conditions	-40°C to +85°C		-40°C to +125°C		Unit
			Min	Max	Min	Max	
V _{IH}	HIGH-Level Input Voltage	Data Input					
		V _{CC1} = 1.2V	0.8V _{CC1}	—	0.8V _{CC1}	—	V
		V _{CC1} = 1.4V to 1.95V	0.65V _{CC1}	—	0.65V _{CC1}	—	V
		V _{CC1} = 2.3V to 2.7V	1.7	—	1.7	—	V
		V _{CC1} = 3.0V to 3.6V	2.0	—	2.0	—	V
		V _{CC1} = 4.5V to 5.5V	0.7V _{CC1}	—	0.7V _{CC1}	—	V
		DIR Input					
		V _{CC1} = 1.2V	0.8V _{CC(A)}	—	0.8V _{CC(A)}	—	V
		V _{CC1} = 1.4V to 1.95V	0.65V _{CC(A)}	—	0.65V _{CC(A)}	—	V
		V _{CC1} = 2.3V to 2.7V	1.7	—	1.7	—	V
		V _{CC1} = 3.0V to 3.6V	2.0	—	2.0	—	V
		V _{CC1} = 4.5V to 5.5V	0.7V _{CC(A)}	—	0.7V _{CC(A)}	—	V
V _{IL}	LOW-Level Input Voltage	Data Input					
		V _{CC1} = 1.2V	—	0.2V _{CC1}	—	0.2V _{CC1}	V
		V _{CC1} = 1.4V to 1.95V	—	0.35V _{CC1}	—	0.35V _{CC1}	V
		V _{CC1} = 2.3V to 2.7V	—	0.7	—	0.7	V
		V _{CC1} = 3.0V to 3.6V	—	0.8	—	0.8	V
		V _{CC1} = 4.5V to 5.5V	—	0.3V _{CC1}	—	0.3V _{CC1}	V

Electrical Characteristics (continued) (@T_A = +25°C.)

Symbol	Parameter	Conditions	-40°C to +85°C		-40°C to +125°C		Unit
			Min	Max	Min	Max	
V _{IL}	LOW-Level Input Voltage	DIR Input					
		V _{CCI} = 1.2V	—	0.2V _{CC(A)}	—	0.2V _{CC(A)}	V
		V _{CCI} = 1.4V to 1.95V	—	0.35V _{CC(A)}	—	0.35V _{CC(A)}	V
		V _{CCI} = 2.3V to 2.7V	—	0.7	—	0.7	V
		V _{CCI} = 3.0V to 3.6V	—	0.8	—	0.8	V
		V _{CCI} = 4.5V to 5.5V	—	0.3V _{CC(A)}	—	0.3V _{CC(A)}	V
V _{OH}	HIGH-Level Output Voltage	V _I = V _{IH}					
		I _O = -100μA V _{CCO} = 1.2V to 4.5V	V _{CCO} - 0.1	—	V _{CCO} - 0.1	—	V
		I _O = -6mA; V _{CCO} = 1.4V	1.0	—	1.0	—	V
		I _O = -8mA; V _{CCO} = 1.65V	1.2	—	1.2	—	V
		I _O = -12mA; V _{CCO} = 2.3V	1.9	—	1.9	—	V
		I _O = -24mA; V _{CCO} = 3.0V	2.4	—	2.4	—	V
		I _O = -32mA; V _{CCO} = 4.5V	3.8	—	3.8	—	V
V _{OL}	LOW-Level Output Voltage	V _I = V _{IL}					
		I _O = 100μA; V _{CCO} = 1.2V to 4.5V	—	0.1	—	0.1	V
		I _O = 6mA; V _{CCO} = 1.4V	—	0.3	—	0.3	V
		I _O = 8mA; V _{CCO} = 1.65V	—	0.45	—	0.45	V
		I _O = 12mA; V _{CCO} = 2.3V	—	0.3	—	0.3	V
		I _O = 24mA; V _{CCO} = 3.0V	—	0.55	—	0.55	V
		I _O = 32mA; V _{CCO} = 4.5V	—	0.55	—	0.55	V
I _I	Input Leakage Current	DIR Input; V _I = 0V to 5.5V; V _{CCI} = 1.2V to 5.5V	—	±2	—	±10	μA
I _{OZ}	OFF-State Output Current	A or B Port; V _O = 0V or V _{CCO} ; V _{CCO} = 1.2V to 5.5V	—	±2	—	±10	μA
I _{BHL}	Bus Hold LOW Current	A or B Port					
		V _I = 0.49V; V _{CCI} = 1.4V	15	—	10	—	μA
		V _I = 0.58V; V _{CCI} = 1.65V	25	—	20	—	μA
		V _I = 0.70V; V _{CCI} = 2.3V	45	—	45	—	μA
		V _I = 0.80V; V _{CCI} = 3.0V	100	—	80	—	μA
		V _I = 1.35V; V _{CCI} = 4.5V	100	—	100	—	μA
I _{BHH}	Bus Hold HIGH Current	A or B Port					
		V _I = 0.91V; V _{CCI} = 1.4V	-15	—	-10	—	μA
		V _I = 1.07V; V _{CCI} = 1.65V	-25	—	-20	—	μA
		V _I = 1.60V; V _{CCI} = 2.3V	-45	—	-45	—	μA
		V _I = 2.00V; V _{CCI} = 3.0V	-100	—	-80	—	μA
		V _I = 3.15V; V _{CCI} = 4.5V	-100	—	-100	—	μA

Electrical Characteristics (continued) (@T_A = +25°C.)

Symbol	Parameter	Conditions	-40°C to +85°C		-40°C to +125°C		Unit
			Min	Max	Min	Max	
I _{BHLO}	Bus Hold LOW Overdrive Current	A or B Port					
		V _{CCI} = 1.6V	125	—	125	—	μA
		V _{CCI} = 1.95V	200	—	200	—	μA
		V _{CCI} = 2.7V	300	—	300	—	μA
		V _{CCI} = 3.6V	500	—	500	—	μA
		V _{CCI} = 5.5V	900	—	900	—	μA
I _{BHHO}	Bus Hold HIGH Overdrive Current	A or B port					
		V _{CCI} = 1.6V	-125	—	-125	—	μA
		V _{CCI} = 1.95V	-200	—	-200	—	μA
		V _{CCI} = 2.7V	-300	—	-300	—	μA
		V _{CCI} = 3.6V	-500	—	-500	—	μA
		V _{CCI} = 5.5V	-900	—	-900	—	μA
I _{OFF}	Power-Off Leakage Current	A Port; V _I or V _O = 0V to 5.5V; V _{CC} (A) = 0V; V _{CC} (B) = 1.2V to 5.5V	—	±2	—	±10	μA
		B Port; V _I or V _O = 0V to 5.5V; V _{CC} (B) = 0V; V _{CC} (A) = 1.2V to 5.5V	—	±2	—	±10	μA
I _{CC}	Supply Current	A Port; V _I = 0V or V _{CCI} ; I _O = 0A	—	—	—	—	—
		V _{CC} (A), V _{CC} (B) = 1.2V to 5.5V	—	8	—	8	μA
		V _{CC} (A), V _{CC} (B) = 1.65V to 5.5V	—	3	—	3	μA
		V _{CC} (A) = 5.5V; V _{CC} (B) = 0V	—	2	—	2	μA
		V _{CC} (A) = 0V; V _{CC} (B) = 5.5V	-2	—	-2	—	μA
		B Port; V _I = 0V or V _{CCI} ; I _O = 0A	—	—	—	—	—
		V _{CC} (A), V _{CC} (B) = 1.2V to 5.5V	—	8	—	8	μA
		V _{CC} (A), V _{CC} (B) = 1.65V to 5.5V	—	3	—	3	μA
		V _{CC} (A) = 5.5V; V _{CC} (B) = 0V	-2	—	-2	—	μA
		V _{CC} (A) = 0V; V _{CC} (B) = 5.5V	—	2	—	2	μA
		A Plus B Port (I _{CC} (A) + I _{CC} (B)); I _O = 0A; V _I = 0V or V _{CCI}	—	—	—	—	—
		V _{CC} (A), V _{CC} (B) = 1.2V to 5.5V	—	16	—	16	μA
		V _{CC} (A), V _{CC} (B) = 1.65V to 5.5V	—	4	—	4	μA

Package Characteristics ($V_{CC} = 3.3V$, $T_A = +25^{\circ}C$, unless otherwise specified.)

Symbol	Parameter	Package	Test Conditions	Min	Typ	Max	Unit
Θ_{JA}	Thermal Resistance Junction-to-Ambient	X2-DFN1210-8	Note 8	—	295	—	$^{\circ}C/W$
		X2-DFN1410-8		—	133	—	
Θ_{JC}	Thermal Resistance Junction-to-Case	X2-DFN1210-8	Note 8	—	280	—	$^{\circ}C/W$
		X2-DFN1410-8		—	127	—	

Note: 8. Test condition for X2-DFN1210-8 and X2-DFN1410-8: Device mounted on FR-4 substrate PCB, 2oz copper with minimum recommended pad layout.

Switching Characteristics ($V_{CC(A)} = 1.2V$, $T_A = +25^{\circ}C$, see Figure 1)

Parameter	From (Input)	To (Output)	$V_{CC(B)} = 1.2V$	$V_{CC(B)} = 1.5V$	$V_{CC(B)} = 1.8V$	$V_{CC(B)} = 2.5V$	$V_{CC(B)} = 3.3V$	$V_{CC(B)} = 5V$	Unit
			Typ	Typ	Typ	Typ	Typ	Typ	
t_{pLH}	A	B	10.6	8.1	7.0	5.8	5.3	5.1	ns
	B	A	10.6	9.5	9.0	8.5	8.3	8.2	
t_{pHL}	A	B	10.1	7.1	6.0	5.3	5.2	5.4	ns
	B	A	10.1	8.6	8.1	7.8	7.6	7.6	
t_{pHZ}	DIR	A	9.4	9.4	9.4	9.4	9.4	9.4	ns
	DIR	B	12.0	9.4	9.0	7.8	8.4	7.9	
t_{pLZ}	DIR	A	7.1	7.1	7.1	7.1	7.1	7.1	ns
	DIR	B	9.5	7.8	7.7	6.9	7.6	7.0	
t_{pZH}	DIR	A	20.1	17.3	16.7	15.4	15.9	15.2	ns
	DIR	B	17.7	15.2	14.1	12.9	12.4	12.2	
t_{pZL}	DIR	A	22.1	18.0	17.1	15.6	16.0	15.5	ns
	DIR	B	19.5	16.5	15.4	14.7	14.6	14.8	

Switching Characteristics ($V_{CC}(B) = 1.2V$, $T_A = 25^\circ C$, see Figure 1)

Parameter	From (Input)	To (Output)	$V_{CC}(A) = 1.2V$	$V_{CC}(A) = 1.5V$	$V_{CC}(A) = 1.8V$	$V_{CC}(A) = 2.5V$	$V_{CC}(A) = 3.3V$	$V_{CC}(A) = 5V$	Unit
			Typ	Typ	Typ	Typ	Typ	Typ	
t_{pLH}	A	B	10.6	9.5	9.0	8.5	8.3	8.2	ns
	B	A	10.6	8.1	7.0	5.8	5.3	5.1	
t_{pHL}	A	B	10.1	8.6	8.1	7.8	7.6	7.6	ns
	B	A	10.1	7.1	6.0	5.3	5.2	5.4	
t_{pHZ}	DIR	A	9.4	6.5	5.7	4.1	4.1	3.0	ns
	DIR	B	12.0	6.1	5.4	4.6	4.3	4.0	
t_{pLZ}	DIR	A	7.1	4.9	4.5	3.2	3.4	2.5	ns
	DIR	B	9.5	7.3	6.6	5.9	5.7	5.6	
t_{pZH}	DIR	A	20.1	15.4	13.6	11.7	11.0	10.7	ns
	DIR	B	17.7	14.4	13.5	11.7	11.7	10.7	
t_{pZL}	DIR	A	22.1	13.2	11.4	9.9	9.5	9.4	ns
	DIR	B	19.5	15.1	13.8	11.9	11.7	10.6	

Switching Characteristics ($V_{CC}(A) = 1.5V \pm 0.1V$, $T_A = -40^\circ C$ to $+85^\circ C$, see Figure 1)

Parameter	From (Input)	To (Output)	$V_{CC}(B) = 1.5V \pm 0.1V$		$V_{CC}(B) = 1.8V \pm 0.15V$		$V_{CC}(B) = 2.5V \pm 0.2V$		$V_{CC}(B) = 3.3V \pm 0.3V$		$V_{CC}(B) = 5V \pm 0.5V$		Unit
			Min	Max	Min	Max	Min	Max	Min	Max	Min	Max	
t_{pLH}	A	B	2.8	21.3	2.4	17.6	2.0	13.5	1.7	11.8	1.6	10.5	ns
	B	A	2.8	21.3	2.6	19.1	2.3	14.9	2.3	12.4	2.2	12.0	
t_{pHL}	A	B	2.6	19.3	2.2	15.3	1.8	11.8	1.7	10.9	1.7	10.8	ns
	B	A	2.6	19.3	2.4	17.3	2.3	13.2	2.2	11.3	2.3	11.0	
t_{pHZ}	DIR	A	3.0	18.7	3.0	18.7	3.0	18.7	3.0	18.7	3.0	18.7	ns
	DIR	B	3.5	24.8	3.5	23.6	3.0	11.0	3.3	11.3	2.8	10.3	
t_{pLZ}	DIR	A	2.4	11.4	2.4	11.4	2.4	11.4	2.4	11.4	2.4	11.4	ns
	DIR	B	2.8	18.3	3.0	17.2	2.5	9.4	3.0	10.1	2.5	9.4	
t_{pZH}	DIR	A	—	39.6	—	36.3	—	24.3	—	22.5	—	21.4	ns
	DIR	B	—	32.7	—	29.0	—	24.9	—	23.2	—	21.9	
t_{pZL}	DIR	A	—	44.1	—	40.9	—	24.2	—	22.6	—	21.3	ns
	DIR	B	—	38.0	—	34.0	—	30.5	—	29.6	—	29.5	

Switching Characteristics (continued) ($V_{CC}(A) = 1.8V \pm 0.15V$, $T_A = -40^\circ C$ to $+85^\circ C$, see Figure 1)

Parameter	From (Input)	To (Output)	$V_{CC}(B) = 1.5V \pm 0.1V$		$V_{CC}(B) = 1.8V \pm 0.15V$		$V_{CC}(B) = 2.5V \pm 0.2V$		$V_{CC}(B) = 3.3V \pm 0.3V$		$V_{CC}(B) = 5V \pm 0.5V$		Unit
			Min	Max	Min	Max	Min	Max	Min	Max	Min	Max	
t_{pLH}	A	B	2.6	19.1	2.2	17.7	2.2	9.3	1.7	7.2	1.4	6.8	ns
	B	A	2.4	17.6	2.2	17.7	2.3	16.0	2.1	15.5	1.9	15.1	
t_{pHL}	A	B	2.4	17.3	2.0	14.3	1.6	8.5	1.8	7.1	1.7	7.0	ns
	B	A	2.2	15.3	2.0	14.3	2.1	12.9	2.0	12.6	1.8	12.2	
t_{pHZ}	DIR	A	2.9	17.1	2.9	17.1	2.9	17.1	2.9	17.1	2.9	17.1	ns
	DIR	B	3.2	24.1	3.2	21.9	2.7	11.5	3.0	10.3	2.5	8.2	
t_{pLZ}	DIR	A	2.4	10.5	2.4	10.5	2.4	10.5	2.4	10.5	2.4	10.5	ns
	DIR	B	2.5	17.6	2.6	16.0	2.2	9.2	2.7	8.4	2.4	7.1	
t_{pZH}	DIR	A	—	35.2	—	33.7	—	25.2	—	23.9	—	22.2	ns
	DIR	B	—	29.6	—	28.2	—	19.8	—	17.7	—	17.3	
t_{pZL}	DIR	A	—	39.4	—	36.2	—	24.4	—	22.9	—	20.4	ns
	DIR	B	—	34.4	—	31.4	—	25.6	—	24.2	—	24.1	

Switching Characteristics (continued) ($V_{CC}(A) = 2.5V \pm 0.2V$, $T_A = -40^\circ C$ to $+85^\circ C$, see Figure 1)

Parameter	From (Input)	To (Output)	$V_{CC}(B) = 1.5V \pm 0.1V$		$V_{CC}(B) = 1.8V \pm 0.15V$		$V_{CC}(B) = 2.5V \pm 0.2V$		$V_{CC}(B) = 3.3V \pm 0.3V$		$V_{CC}(B) = 5V \pm 0.5V$		Unit
			Min	Max	Min	Max	Min	Max	Min	Max	Min	Max	
t_{pLH}	A	B	2.3	17.9	2.3	16.0	1.5	8.5	1.3	6.2	1.1	4.8	ns
	B	A	2.0	13.5	2.2	9.3	1.5	8.5	1.4	8.0	1.0	7.5	
t_{pHL}	A	B	2.3	15.8	2.1	12.9	1.4	7.5	1.3	5.4	0.9	4.6	ns
	B	A	1.8	11.8	1.9	8.5	1.4	7.5	1.3	7.0	0.9	6.2	
t_{pHZ}	DIR	A	2.1	8.1	2.1	8.1	2.1	8.1	2.1	8.1	2.1	8.1	ns
	DIR	B	3.0	22.5	3.0	21.4	2.5	11.0	2.8	9.3	2.3	6.9	
t_{pLZ}	DIR	A	1.7	5.8	1.7	5.8	1.7	5.8	1.7	5.8	1.7	5.8	ns
	DIR	B	2.3	14.6	2.5	13.2	2.0	9.0	2.5	8.4	1.8	5.8	
t_{pZH}	DIR	A	—	28.1	—	22.5	—	17.5	—	16.4	—	13.3	ns
	DIR	B	—	23.7	—	21.8	—	14.3	—	12.0	—	10.6	
t_{pZL}	DIR	A	—	34.3	—	29.9	—	18.5	—	16.3	—	13.1	ns
	DIR	B	—	23.9	—	21.0	—	15.6	—	13.5	—	12.7	

Switching Characteristics (continued) ($V_{CC}(A) = 3.3V \pm 0.3V$, $T_A = -40^\circ C$ to $+85^\circ C$, see Figure 1)

Parameter	From (Input)	To (Output)	$V_{CC}(B) = 1.5V \pm 0.1V$		$V_{CC}(B) = 1.8V \pm 0.15V$		$V_{CC}(B) = 2.5V \pm 0.2V$		$V_{CC}(B) = 3.3V \pm 0.3V$		$V_{CC}(B) = 5V \pm 0.5V$		Unit
			Min	Max	Min	Max	Min	Max	Min	Max	Min	Max	
t_{pLH}	A	B	2.3	17.1	2.1	15.5	1.4	8.0	0.8	5.6	0.7	4.4	ns
	B	A	1.7	11.8	1.7	7.2	1.3	6.2	0.7	5.6	0.6	5.4	
t_{pHL}	A	B	2.2	15.6	2.0	12.6	1.3	7.0	0.8	5.0	0.7	4.0	ns
	B	A	1.7	10.9	1.8	7.1	1.3	5.4	0.8	5.0	0.7	4.5	
t_{pHZ}	DIR	A	2.3	7.3	2.3	7.3	2.3	7.3	2.3	7.3	2.7	7.3	ns
	DIR	B	2.9	18.0	2.9	16.5	2.3	10.1	2.7	8.6	2.2	6.3	
t_{pLZ}	DIR	A	2.0	5.6	2.0	5.6	2.0	5.6	2.0	5.6	2.0	5.6	ns
	DIR	B	2.3	13.6	2.4	12.5	1.9	7.8	2.3	7.1	1.7	4.9	
t_{pZH}	DIR	A	—	25.4	—	19.7	—	14.0	—	12.7	—	10.3	ns
	DIR	B	—	22.7	—	21.1	—	13.6	—	11.2	—	10.0	
t_{pZL}	DIR	A	—	28.9	—	23.6	—	15.5	—	13.6	—	10.8	ns
	DIR	B	—	22.9	—	19.9	—	14.3	—	12.3	—	11.3	

Switching Characteristics (continued) ($V_{CC}(A) = 5.0V \pm 0.5V$, $T_A = -40^\circ C$ to $+85^\circ C$, see Figure 1)

Parameter	From (Input)	To (Output)	$V_{CC}(B) = 1.5V \pm 0.1V$		$V_{CC}(B) = 1.8V \pm 0.15V$		$V_{CC}(B) = 2.5V \pm 0.2V$		$V_{CC}(B) = 3.3V \pm 0.3V$		$V_{CC}(B) = 5V \pm 0.5V$		Unit
			Min	Max	Min	Max	Min	Max	Min	Max	Min	Max	
t_{pLH}	A	B	2.2	16.6	1.9	15.1	1.0	7.5	0.7	5.4	0.5	3.9	ns
	B	A	1.6	10.5	1.4	6.8	1.0	4.8	0.7	4.4	0.5	3.9	
t_{pHL}	A	B	2.3	15.3	1.8	12.2	1.0	6.2	0.7	4.5	0.5	3.5	ns
	B	A	1.7	10.8	1.7	7.0	0.9	4.6	0.7	4.0	0.5	3.5	
t_{pHZ}	DIR	A	1.7	5.4	1.7	5.4	1.7	5.4	1.7	5.4	1.7	5.4	ns
	DIR	B	2.9	17.3	2.9	16.1	2.3	9.7	2.7	8.0	2.5	5.7	
t_{pLZ}	DIR	A	1.4	3.7	1.4	3.7	1.3	3.7	1.0	3.7	0.9	3.7	ns
	DIR	B	2.3	13.1	2.4	12.1	1.9	7.4	2.3	7.0	1.8	4.5	
t_{pZH}	DIR	A	—	23.6	—	18.9	—	12.2	—	11.4	—	8.4	ns
	DIR	B	—	20.3	—	18.8	—	11.2	—	9.1	—	7.6	
t_{pZL}	DIR	A	—	28.1	—	23.1	—	14.3	—	12.0	—	9.2	ns
	DIR	B	—	20.7	—	17.6	—	11.6	—	9.9	—	8.9	

Switching Characteristics (continued) ($V_{CC(A)} = 1.5V \pm 0.1V$, $T_A = -40^\circ C$ to $+125^\circ C$, see Figure 1)

Parameter	From (Input)	To (Output)	$V_{CC(B)} = 1.5V \pm 0.1V$		$V_{CC(B)} = 1.8V \pm 0.15V$		$V_{CC(B)} = 2.5V \pm 0.2V$		$V_{CC(B)} = 3.3V \pm 0.3V$		$V_{CC(B)} = 5V \pm 0.5V$		Unit
			Min	Max	Min	Max	Min	Max	Min	Max	Min	Max	
t_{pLH}	A	B	2.5	23.5	2.1	19.4	1.8	14.9	1.5	13.0	1.4	11.6	ns
	B	A	2.5	23.5	2.3	21.1	2.0	16.4	2.0	13.7	1.9	13.2	
t_{pHL}	A	B	2.3	21.3	1.9	16.9	1.6	13.0	1.5	12.0	1.5	11.9	ns
	B	A	2.3	21.3	2.1	19.1	2.0	14.6	1.9	12.5	2.0	12.1	
t_{pHZ}	DIR	A	2.7	20.6	2.7	20.6	2.7	20.6	2.7	20.6	2.7	20.6	ns
	DIR	B	3.1	27.3	3.1	26.0	2.7	12.1	2.9	12.5	2.5	11.4	
t_{pLZ}	DIR	A	2.1	12.6	2.1	12.6	2.1	12.6	2.1	12.6	2.1	12.6	ns
	DIR	B	2.5	20.2	2.7	19.0	2.2	10.4	2.7	11.2	2.2	10.4	
t_{pZH}	DIR	A	—	43.7	—	40.1	—	26.8	—	24.9	—	23.6	ns
	DIR	B	—	36.1	—	32.0	—	27.5	—	25.6	—	24.2	
t_{pZL}	DIR	A	—	48.6	—	45.1	—	26.7	—	25.0	—	23.5	ns
	DIR	B	—	41.9	—	37.5	—	33.6	—	32.6	—	32.5	

Switching Characteristics (continued) ($V_{CC(A)} = 1.8V \pm 0.15V$, $T_A = -40^\circ C$ to $+125^\circ C$, see Figure 1)

Parameter	From (Input)	To (Output)	$V_{CC(B)} = 1.5V \pm 0.1V$		$V_{CC(B)} = 1.8V \pm 0.15V$		$V_{CC(B)} = 2.5V \pm 0.2V$		$V_{CC(B)} = 3.3V \pm 0.3V$		$V_{CC(B)} = 5V \pm 0.5V$		Unit
			Min	Max	Min	Max	Min	Max	Min	Max	Min	Max	
t_{pLH}	A	B	2.3	21.1	1.9	19.5	1.9	10.3	1.5	8.0	1.2	7.5	ns
	B	A	2.1	19.4	1.9	19.5	2.0	17.6	1.8	17.1	1.7	16.7	
t_{pHL}	A	B	2.1	19.1	1.8	15.8	1.4	9.4	1.6	7.9	1.5	7.7	ns
	B	A	1.9	16.9	1.8	15.8	1.8	14.2	1.8	13.9	1.6	13.5	
t_{pHZ}	DIR	A	2.6	18.9	2.6	18.9	2.6	18.9	2.6	18.9	2.6	18.9	ns
	DIR	B	2.8	26.6	2.8	24.1	2.4	12.7	2.7	11.4	2.2	9.1	
t_{pLZ}	DIR	A	2.1	11.6	2.1	11.6	2.1	11.6	2.1	11.6	2.1	11.6	ns
	DIR	B	2.2	19.4	2.3	17.6	1.9	10.2	2.4	9.3	2.1	7.9	
t_{pZH}	DIR	A	—	38.8	—	37.1	—	27.8	—	26.4	—	24.6	ns
	DIR	B	—	32.7	—	31.1	—	21.9	—	19.6	—	19.1	
t_{pZL}	DIR	A	—	43.5	—	39.9	—	26.9	—	25.3	—	22.6	ns
	DIR	B	—	38.0	—	34.7	—	28.3	—	26.8	—	26.6	

Switching Characteristics (continued) ($V_{CC(A)} = 2.5V \pm 0.2V$, $T_A = -40^\circ C$ to $+125^\circ C$, see Figure 1)

Parameter	From (Input)	To (Output)	$V_{CC(B)} = 1.5V \pm 0.1V$		$V_{CC(B)} = 1.8V \pm 0.15V$		$V_{CC(B)} = 2.5V \pm 0.2V$		$V_{CC(B)} = 3.3V \pm 0.3V$		$V_{CC(B)} = 5V \pm 0.5V$		Unit
			Min	Max	Min	Max	Min	Max	Min	Max	Min	Max	
t_{pLH}	A	B	2.0	19.7	2.0	17.6	1.3	9.4	1.1	6.9	0.9	5.3	ns
	B	A	1.8	14.9	1.9	10.3	1.3	9.4	1.2	8.8	0.9	8.3	
t_{pHL}	A	B	2.0	17.4	1.8	14.2	1.2	8.3	1.1	6.0	0.8	5.1	ns
	B	A	1.6	13.0	1.7	9.4	1.2	8.3	1.1	7.7	0.8	6.9	
t_{pHZ}	DIR	A	1.8	9.0	1.8	9.0	1.8	9.0	1.8	9.0	1.8	9.0	ns
	DIR	B	2.7	24.8	2.7	23.6	2.2	12.1	2.5	10.3	2.0	7.6	
t_{pLZ}	DIR	A	1.5	6.4	1.5	6.4	1.5	6.4	1.5	6.4	1.5	6.4	ns
	DIR	B	2.0	16.1	2.2	14.6	1.8	9.9	2.2	9.3	1.6	6.4	
t_{pZH}	DIR	A	—	31.0	—	24.9	—	19.3	—	18.1	—	14.7	ns
	DIR	B	—	26.1	—	24.0	—	15.8	—	13.3	—	11.7	
t_{pZL}	DIR	A	—	37.8	—	33.0	—	20.4	—	18.0	—	14.5	ns
	DIR	B	—	26.4	—	23.2	—	17.3	—	15.0	—	14.1	

Switching Characteristics (continued) ($V_{CC}(A) = 3.3V \pm 0.3V$, $T_A = -40^\circ C$ to $+125^\circ C$, see Figure 1)

Parameter	From (Input)	To (Output)	$V_{CC}(B) = 1.5V \pm 0.1V$		$V_{CC}(B) = 1.8V \pm 0.15V$		$V_{CC}(B) = 2.5V \pm 0.2V$		$V_{CC}(B) = 3.3V \pm 0.3V$		$V_{CC}(B) = 5V \pm 0.5V$		Unit
			Min	Max	Min	Max	Min	Max	Min	Max	Min	Max	
t_{pLH}	A	B	2.0	18.9	1.8	17.1	1.2	8.8	0.7	6.2	0.6	4.9	ns
	B	A	1.5	13.0	1.5	8.0	1.1	6.9	0.6	6.2	0.5	6.0	
t_{pHL}	A	B	1.9	17.2	1.8	13.9	1.1	7.7	0.7	5.5	0.6	4.4	ns
	B	A	1.5	12.0	1.6	7.9	1.1	6.0	0.7	5.5	0.6	5.0	
t_{pHZ}	DIR	A	2.0	8.1	2.0	8.1	2.0	8.1	2.0	8.1	2.4	8.1	ns
	DIR	B	2.6	19.8	2.6	18.2	2.0	11.2	2.4	9.5	1.9	7.0	
t_{pLZ}	DIR	A	1.8	6.2	1.8	6.2	1.8	6.2	1.8	6.2	1.8	6.2	ns
	DIR	B	2.0	15.0	2.1	13.8	1.7	8.6	2.0	7.9	1.5	5.4	
t_{pZH}	DIR	A	—	28.0	—	21.8	—	15.5	—	14.1	—	11.4	ns
	DIR	B	—	25.1	—	23.3	—	15.0	—	12.4	—	11.1	
t_{pZL}	DIR	A	—	31.8	—	26.1	—	17.2	—	15.0	—	12.0	ns
	DIR	B	—	25.3	—	22.0	—	15.8	—	13.6	—	12.5	

Switching Characteristics (continued) ($V_{CC}(A) = 5.0V \pm 0.5V$, $T_A = -40^\circ C$ to $+125^\circ C$, see Figure 1)

Parameter	From (Input)	To (Output)	$V_{CC}(B) = 1.5V \pm 0.1V$		$V_{CC}(B) = 1.8V \pm 0.15V$		$V_{CC}(B) = 2.5V \pm 0.2V$		$V_{CC}(B) = 3.3V \pm 0.3V$		$V_{CC}(B) = 5V \pm 0.5V$		Unit
			Min	Max	Min	Max	Min	Max	Min	Max	Min	Max	
t_{pLH}	A	B	1.9	18.3	1.7	16.7	0.9	8.3	0.6	6.0	0.4	4.3	ns
	B	A	1.4	11.6	1.2	7.5	0.9	5.3	0.6	4.9	0.4	4.3	
t_{pHL}	A	B	2.0	16.9	1.6	13.5	0.9	6.9	0.6	5.0	0.4	3.9	ns
	B	A	1.5	11.9	1.5	7.7	0.8	5.1	0.6	4.4	0.4	3.9	
t_{pHZ}	DIR	A	1.5	6.0	1.5	6.0	1.5	6.0	1.5	6.0	1.5	6.0	ns
	DIR	B	2.6	19.1	2.6	17.8	2.0	10.7	2.4	8.8	2.2	6.3	
t_{pLZ}	DIR	A	1.2	4.1	1.2	4.1	1.1	4.1	0.9	4.1	0.8	4.1	ns
	DIR	B	2.0	14.5	2.1	13.4	1.7	8.2	2.0	7.7	1.6	5.0	
t_{pZH}	DIR	A	—	26.1	—	20.9	—	13.5	—	12.6	—	9.3	ns
	DIR	B	—	22.4	—	20.8	—	12.4	—	10.1	—	8.4	
t_{pZL}	DIR	A	—	31.0	—	25.5	—	15.8	—	13.2	—	10.2	ns
	DIR	B	—	22.9	—	19.5	—	12.9	—	11.0	—	9.9	

Operating Characteristics ($T_A = +25^\circ C$, unless otherwise specified.)

Parameter		Test Conditions	$V_{CC}(A) = V_{CC}(B) = 1.8V$	$V_{CC}(A) = V_{CC}(B) = 2.5V$	$V_{CC}(A) = V_{CC}(B) = 3.3V$	$V_{CC}(A) = V_{CC}(B) = 5V$	Unit
Power Dissipation Capacitance			Typ	Typ	Typ	Typ	
$C_{pd}(A)$	A- Input, B- Output	$C_L = 0pF$ $f = 10MHz$ $t_R = t_F = 1ns$	3	4	4	4	pF
	B- Input, A- Output		18	19	20	21	
$C_{pd}(B)$	A- Input, B- Output	$C_L = 0pF$ $f = 10MHz$ $t_R = t_F = 1ns$	18	19	20	21	pF
	B- Input, A- Output		3	4	4	4	

Parameter Measurement Information

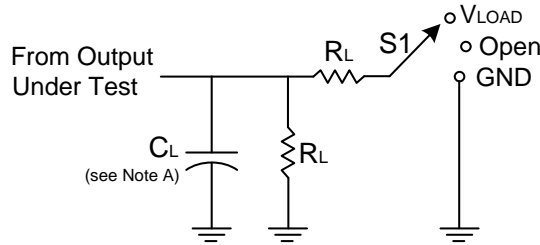

TEST	S1
t _{PLH} /t _{PHL}	Open
t _{PLZ} /t _{PZL}	V _{load}
t _{PHZ} /t _{PZH}	GND

V _{CC}	Inputs		V _M	V _{LOAD}	C _L	R _L	V _Δ
	V _i	t _r /t _f					
1.8V±0.15V	V _{CCI}	≤2ns	V _{CCO} /2	2 X V _{CCO}	15pF	2KΩ	0.15V
2.5V±0.2V	V _{CC}	≤2ns	V _{CCO} /2	2 X V _{CCO}	15pF	2KΩ	0.15V
3.3V±0.3V	3V	≤2.5ns	V _{CCO} /2	2 X V _{CCO}	15pF	2KΩ	0.3V
5V±0.5V	V _{CC}	≤2.5ns	V _{CCO} /2	2 X V _{CCO}	15pF	2KΩ	0.3V

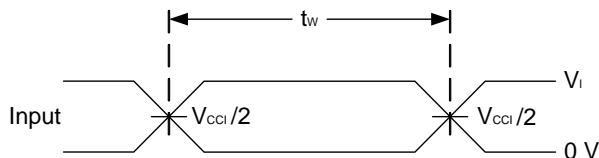

Voltage Waveform Pulse Duration

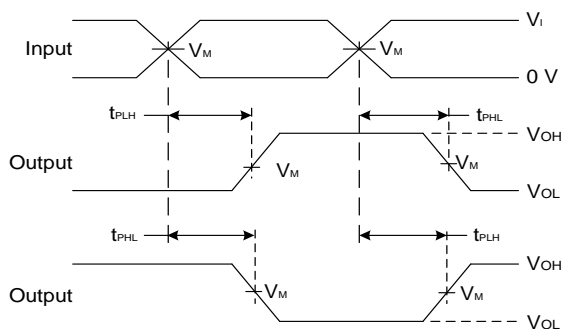

**Voltage Waveform Propagation Delay Times
Inverting and Non Inverting Outputs**

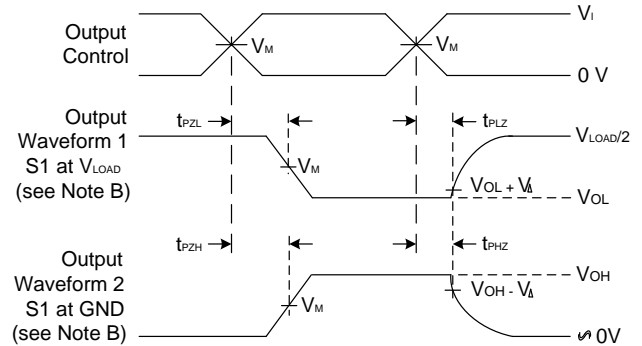

**Voltage Waveform Enable and Disable Times
Low and High Level Enabling**

Figure 1 Load Circuit and Voltage Waveforms

- Notes:
- Includes test lead and test apparatus capacitance.
 - Waveform 1 is for an output with input set up as a low and device coming out or into 3-state via DIR control. Waveform 2 is for an output with input set up as a high and device coming out or into 3-state via DIR control.
 - All pulses are supplied at pulse repetition rate ≤ 10 MHz.
 - t_{PLZ} and t_{PHZ} are the same as t_{dis}.
 - t_{PZL} and t_{PZH} are the same as t_{EN}.
 - t_{PLH} and t_{PHL} are the same as t_{PD}.
 - V_{CCI} is the V_{CC} associated with the input.
 - V_{CCO} is the V_{CC} associated with the output.

Ordering Information

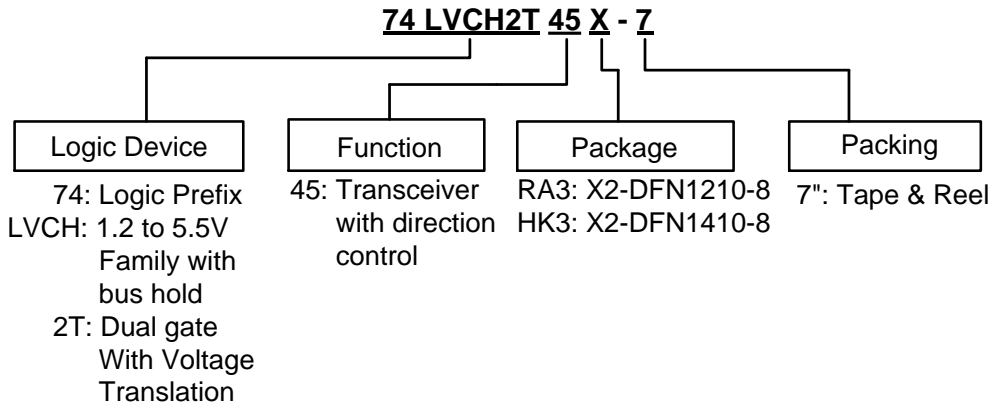

Part Number	Package Code	Packaging	7" Tape and Reel (Note 7)	
			Quantity	Part Number Suffix
74LVCH2T45RA3-7	RA3	X2-DFN1210-8	5000/Tape & Reel	-7
74LVCH2T45HK3-7	HK3	X2-DFN1410-8	5000/Tape & Reel	-7

Note: 17. The taping orientation is located on our website at <http://www.diodes.com/package-outlines.html>.

Marking Information

(1) X2-DFN1210-8

(Top View)

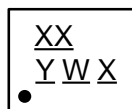

XX : Identification Code
Y : Year : 0~9
W : Week : A~Z : 1~26 week;
a~z : 27~52 week; z represents 52 and 53 week
X : Internal Code

Part Number	Package	Identification Code
74LVCH2T45RA3-7	X2-DFN1210-8	4C

(2) X2-DFN1410-8

(Top View)

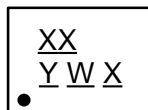

XX : Identification Code
Y : Year : 0~9
W : Week : A~Z : 1~26 week;
a~z : 27~52 week; z represents 52 and 53 week
X : Internal Code

Part Number	Package	Identification Code
74LVCH2T45HK3-7	X2-DFN1410-8	4D

Package Outline Dimensions

Please see <http://www.diodes.com/package-outlines.html> for the latest version.

X2-DFN1210-8

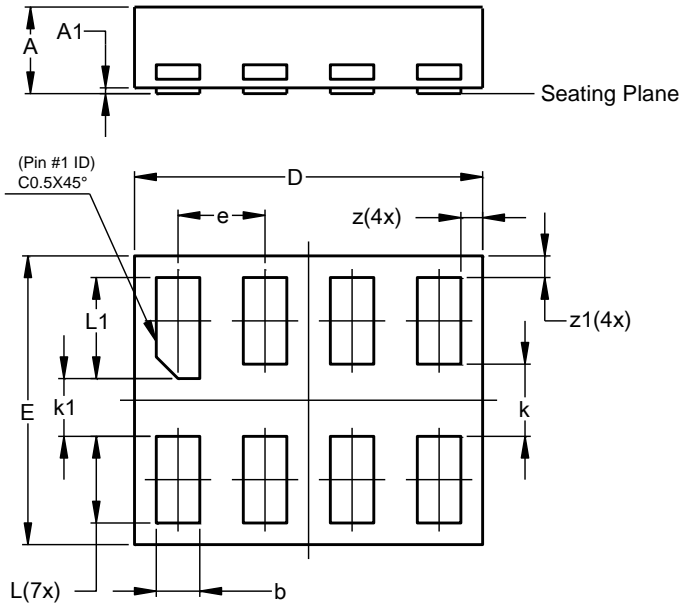

X2-DFN1210-8			
Dim	Min	Max	Typ
A	-	0.35	0.30
A1	0	0.03	0.02
b	0.10	0.20	0.15
D	1.15	1.25	1.20
E	0.95	1.05	1.00
e	-	-	0.30
k	-	-	0.25
k1	-	-	0.20
L	0.25	0.35	0.30
L1	0.30	0.40	0.35
z	0.050	0.100	0.075
z1	0.050	0.100	0.075
All Dimensions in mm			

X2-DFN1410-8

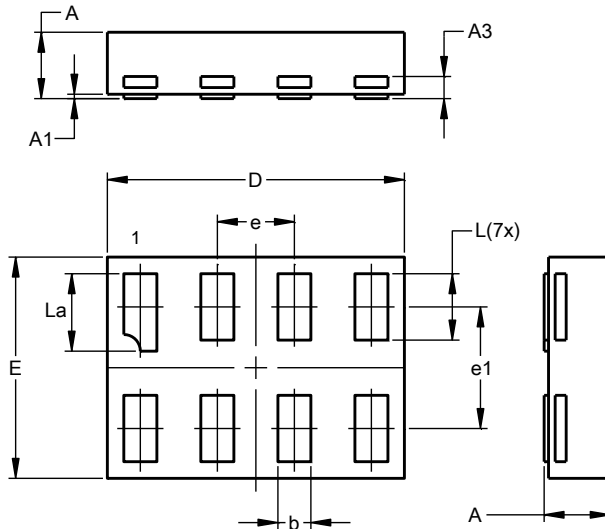

X2-DFN1410-8			
Dim	Min	Max	Typ
A	0.30	0.35	0.33
A1	0.00	0.03	0.02
A3	--	--	0.10
b	0.12	0.20	0.15
D	1.30	1.40	1.35
E	0.95	1.05	1.00
e	--	--	0.35
e1	--	--	0.55
L	0.27	0.35	0.30
L1	0.32	0.40	0.35
All Dimensions in mm			

Suggested Pad Layout

Please see <http://www.diodes.com/package-outlines.html> for the latest version.

X2-DFN1210-8

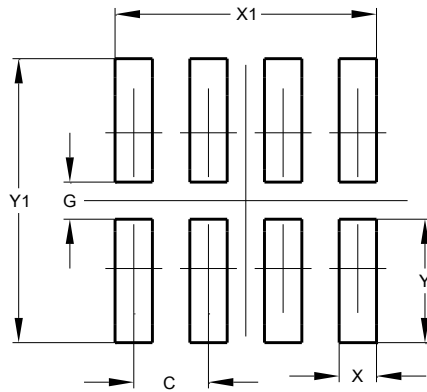

Dimensions	Value (in mm)
C	0.300
G	0.150
X	0.150
X1	1.050
Y	0.500
Y1	1.150

X2-DFN1410-8

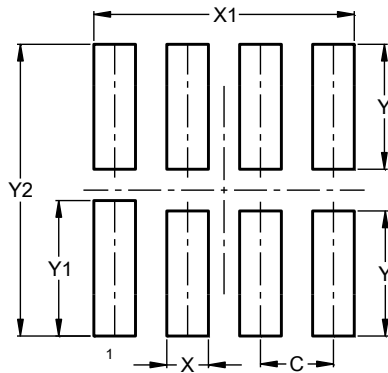

Dimensions	Value (in mm)
C	0.350
X	0.200
X1	1.250
Y	0.600
Y1	0.650
Y2	1.400

Mechanical Data

X2-DFN1210-8

- Moisture Sensitivity: Level 1 per J-STD-020
- Terminals: Finish - NiPdAu Nickel Palladium Gold, Solderable per MIL-STD-202, Method 208④
- Weight: 0.002 grams (Approximate)

X2-DFN1410-8

- Moisture Sensitivity: Level 1 per J-STD-020
- Terminals: Finish - NiPdAu Nickel Palladium Gold, Solderable per MIL-STD-202, Method 208④
- Weight: 0.002 grams (Approximate)