

Features

- High speed: $t_{PD} = 5.5 \text{ ns (typ.)}$ at $V_{CC} = 5 \text{ V}$
- Low power dissipation
 - $I_{CC} = 2 \mu\text{A (max.)}$ at $T_A = 25 \text{ }^\circ\text{C}$
- Typical hysteresis: $V_h = 1 \text{ V}$ at $V_{CC} = 4.5 \text{ V}$
- Power-down protection on inputs
 - Symmetrical output impedance
 $|I_{OH}| = I_{OL} = 8 \text{ mA (min.)}$
- Balanced propagation delay: $t_{PLH} \cong t_{PHL}$
- Operating voltage range
 - $V_{CC} \text{ (opr.)} = 2 \text{ V to } 5.5 \text{ V}$
- Pin and function compatible with 74 series 14
- Improved latch-up immunity
- Low noise
 - $V_{OLP} = 0.8 \text{ V (max.)}$
- ESD performance
 - HBM: 2000 V
 - MM: 200 V
 - CDM: 1000 V

Applications

- Automotive
- Industrial
- Computer
- Consumer



Description

The 74VHC14 device is an advanced high-speed CMOS hex Schmitt inverter manufactured with sub-micron silicon gate and double-layer metal wiring C^2 MOS technology. The internal circuit is composed of 3 stages including a buffer output, which provides high noise immunity and stable output.

Power-down protection is provided on all inputs and 0 to 7 V can be accepted on inputs regardless of the supply voltage. This device can be used to interface from 5 V to 3 V.

Pin configuration and function are the same as those of the 74VHC04 device but the 74VHC14 device has hysteresis.

This along with its Schmitt trigger function allows the device to be used on line receivers with slow rise/fall input signals.

All inputs and outputs are equipped with protection circuits against static discharge, giving them 2 kV ESD immunity and transient excess voltage.

Table 1. Device summary

Order code	Temperature range	Package	Packaging	Marking
74VHC14TTR	-55/+125 °C	TSSOP14	Tape and reel	VHC14
74VHC14YTTR ⁽¹⁾	-40/+125 °C	TSSOP14 (automotive grade)	Tape and reel	VHC14Y
74VHC14MTR	-55/+125 °C	SO-14	Tape and reel	74VHC14
74VHC14YMTR ⁽¹⁾	-40/+125 °C	SO-14 (automotive grade)	Tape and reel	74VHC14Y

1. Qualification and characterization according to AEC Q100 and Q003 or equivalent, advanced screening according to AEC Q001 and Q002 or equivalent.

Contents

- 1 Logic symbols and I/O equivalent circuit 3**

- 2 Pin settings 4**
 - 2.1 Pin connections 4
 - 2.2 Pin description 4
 - 2.3 Truth table 4

- 3 Maximum ratings 5**
 - Recommended operating conditions 5

- 4 Electrical characteristics 6**

- 5 Test circuit 8**

- 6 Waveform 9**

- 7 Package information 10**

- 8 Revision history 15**



1 Logic symbols and I/O equivalent circuit

Figure 1. IEC logic symbols

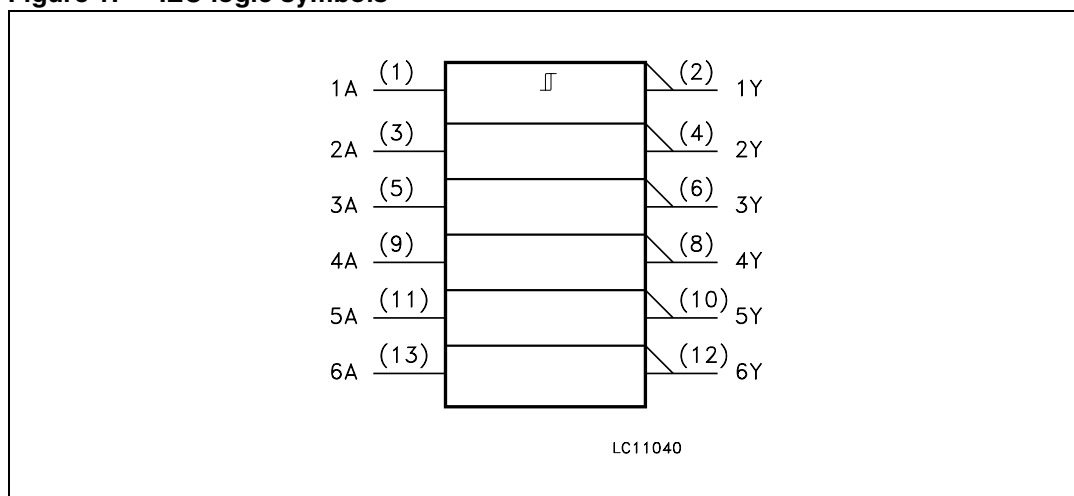
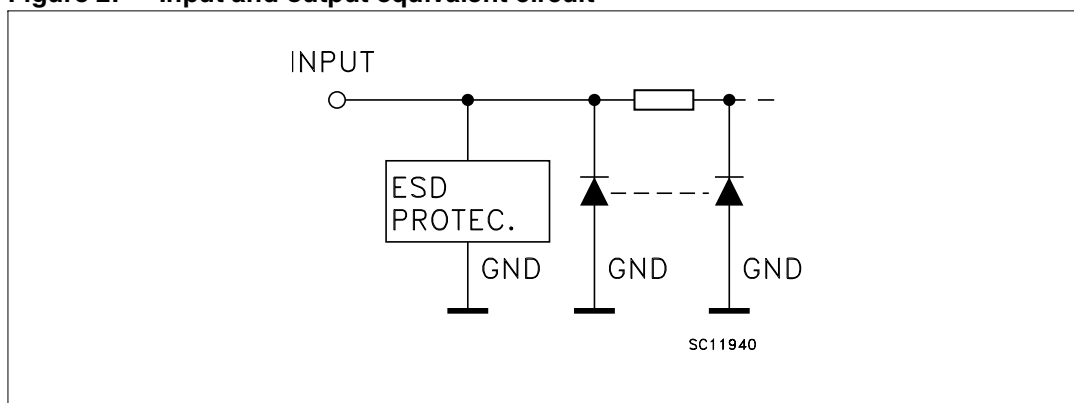

Figure 2. Input and output equivalent circuit



2 Pin settings

2.1 Pin connections

Figure 3. Pin connections (top through view)

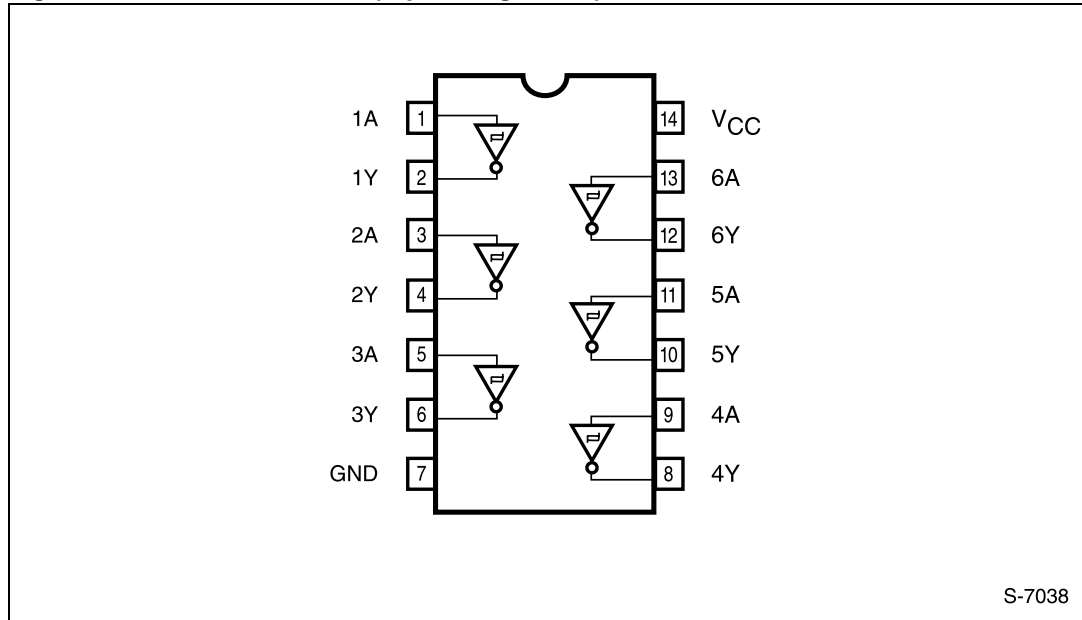

2.2 Pin description

Table 2. Pin description

Pin number	Symbol	Name and function
1, 3, 5, 9, 11, 13	1A to 6A	Data inputs
2, 4, 6, 8, 10, 12	1Y to 6Y	Data outputs
7	GND	Ground (0 V)
14	V _{CC}	Positive supply voltage

2.3 Truth table

Table 3. Truth table

Input	Output
A	Y
L	H
H	L

3 Maximum ratings

Stressing the device above the rating listed in [Table 4: Absolute maximum ratings](#) may cause permanent damage to the device. These are stress ratings only and operation of the device at these or any other conditions above those indicated in [Table 5: Recommended operating conditions](#) of this specification is not implied. Exposure to absolute maximum rating conditions for extended periods may affect device reliability.

Table 4. Absolute maximum ratings

Symbol	Parameter	Value	Unit
V_{CC}	Supply voltage	-0.5 to +7.0	V
V_I	DC input voltage	-0.5 to +7.0	V
V_O	DC output voltage	-0.5 to $V_{CC} + 0.5$	V
I_{IK}	DC input diode current	- 20	mA
I_{OK}	DC output diode current	± 20	mA
I_O	DC output current	± 25	mA
I_{CC}	DC supply current per supply pin	± 50	mA
I_{GND}	DC ground current per supply pin	± 50	mA
T_{stg}	Storage temperature	-65 to +150	°C
T_L	Lead temperature (10 sec.)	300	°C

Recommended operating conditions

Table 5. Recommended operating conditions

Symbol	Parameter	Value	Unit	
V_{CC}	Supply voltage	2 to 5.5	V	
V_I	Input voltage	0 to 5.5	V	
V_O	Output voltage	0 to V_{CC}	V	
T_{op}	Operating temperature	TSSOP14, SO-14	-55 to +125	°C
		TSSOP14 (automotive grade)	-40 to +125	°C

4 Electrical characteristics

Table 6. DC specifications

Symbol	Parameter	Test condition		Value						Unit	
		V _{CC} (V)		T _A = 25 °C			-40 to 85 °C		-55 to 125 °C		
				Min.	Typ.	Max.	Min.	Max.	Min.		Max.
V _{t+}	High level threshold voltage	3.0				2.2		2.2		2.2	V
		4.5				3.15		3.15		3.15	
		5.5				3.85		3.85		3.85	
V _{t-}	Low level threshold voltage	3.0		0.9			0.9		0.9		V
		4.5		1.35			1.35		1.35		
		5.5		1.65			1.65		1.65		
V _h	Hysteresis voltage	3.0		0.3		1.2	0.3	1.2	0.3	1.2	V
		4.5		0.4		1.4	0.4	1.4	0.4	1.4	
		5.5		0.5		1.6	0.5	1.6	0.5	1.6	
V _{OH}	High level output voltage	2.0	I _O = -50 μA	1.9	2.0		1.9		1.9		V
		3.0	I _O = -50 μA	2.9	3.0		2.9		2.9		
		4.5	I _O = -50 μA	4.4	4.5		4.4		4.4		
		3.0	I _O = -4 mA	2.58			2.48		2.4		
		4.5	I _O = -8 mA	3.94			3.8		3.7		
V _{OL}	Low level output voltage	2.0	I _O = 50 μA		0.0	0.1		0.1		0.1	V
		3.0	I _O = 50 μA		0.0	0.1		0.1		0.1	
		4.5	I _O = 50 μA		0.0	0.1		0.1		0.1	
		3.0	I _O = 4 mA			0.36		0.44		0.55	
		4.5	I _O = 8 mA			0.36		0.44		0.55	
I _I	Input leakage current	0 to 5.5	V _I = 5.5 V or GND			±0.1		±1		±1	μA
I _{CC}	Quiescent supply current	5.5	V _I = V _{CC} or GND			2		20		20	μA

Table 7. AC electrical characteristics (input $t_r = t_f = 3$ ns)

Symbol	Parameter	Test condition			Value						Unit	
		V_{CC} (V)	C_L (pF)		$T_A = 25\text{ °C}$			$-40\text{ to }85\text{ °C}$		$-55\text{ to }125\text{ °C}$		
					Min.	Typ.	Max.	Min.	Max.	Min.		Max.
t_{PLH} t_{PHL}	Propagation delay time	3.3 ⁽¹⁾	15			8.3	12.8	1.0	15.0	1.0	15.0	ns
		3.3 ⁽¹⁾	50			10.8	16.3	1.0	18.5	1.0	18.5	
		5.0 ⁽²⁾	15			5.5	8.6	1.0	10.0	1.0	10.0	
		5.0 ⁽²⁾	50			7.0	10.6	1.0	12.0	1.0	12.0	

1. Voltage range is $3.3\text{ V} \pm 0.3\text{ V}$.
2. Voltage range is $5.0\text{ V} \pm 0.5\text{ V}$.

Table 8. Capacitive characteristics

Symbol	Parameter	Test condition			Value						Unit	
					$T_A = 25\text{ °C}$			$-40\text{ to }85\text{ °C}$		$-55\text{ to }125\text{ °C}$		
					Min.	Typ.	Max.	Min.	Max.	Min.		Max.
C_{IN}	Input capacitance					6	10		10		10	pF
C_{PD}	Power dissipation capacitance ⁽¹⁾					14						pF

1. C_{PD} is defined as the value of the IC's internal equivalent capacitance which is calculated from the operating current consumption without load. (Refer to [Section 5: Test circuit](#)). Average operating current can be obtained by the following equation. $I_{CC(opr)} = C_{PD} \times V_{CC} \times f_{IN} + I_{CC}/6$ (per gate).

Table 9. Dynamic switching characteristics

Symbol	Parameter	Test condition		Value						Unit	
		V_{CC} (V)		$T_A = 25\text{ °C}$			$-40\text{ to }85\text{ °C}$		$-55\text{ to }125\text{ °C}$		
				Min.	Typ.	Max.	Min.	Max.	Min.		Max.
V_{OLP}	Dynamic low voltage quiet output ^{(1), (2)}	5.0	$C_L = 50\text{ pF}$		0.3	0.8					V
V_{OLV}				-0.8	-0.3						
V_{IHD}	Dynamic high voltage input ^{(1), (3)}	5.0		3.5						V	
V_{ILD}	Dynamic low voltage input ^{(1), (3)}	5.0				1.5					V

1. Worst case package.
2. Max number of outputs defined as (n). Data inputs are driven 0 V to 5.0 V, (n-1) outputs switching and one output at GND.
3. Max number of data inputs (n) switching. (n-1) switching 0 V to 5.0 V. Inputs under test switching: 5.0 V to threshold (V_{ILD}), 0 V to threshold (V_{IHD}), $f = 1\text{ MHz}$.

5 Test circuit

Figure 4. Test circuit

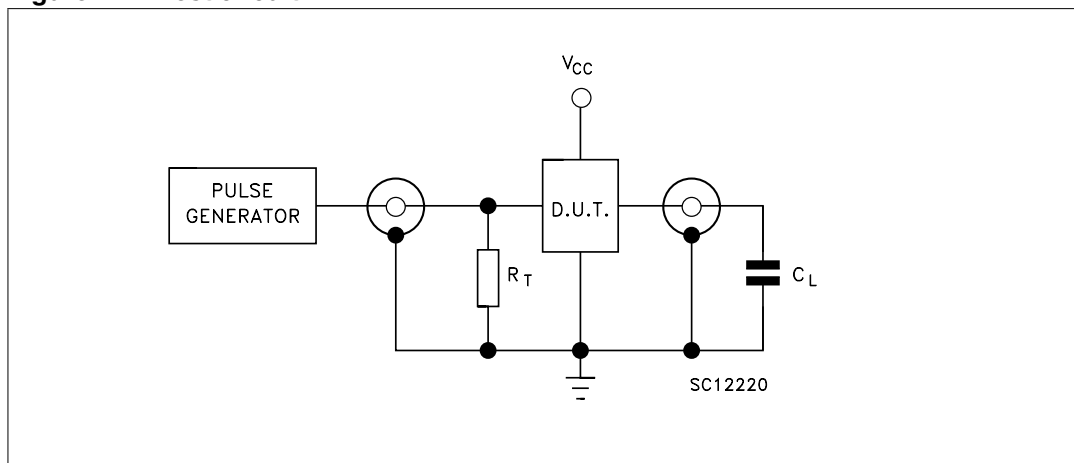

Note: $C_L = 15/50$ pF or equivalent (includes jig and probe capacitance)
 $R_T = Z_{OUT}$ of pulse generator (typically 50Ω).

6 Waveform

Figure 5. Waveform - propagation delay ($f = 1\text{ MHz}$; 50% duty cycle)

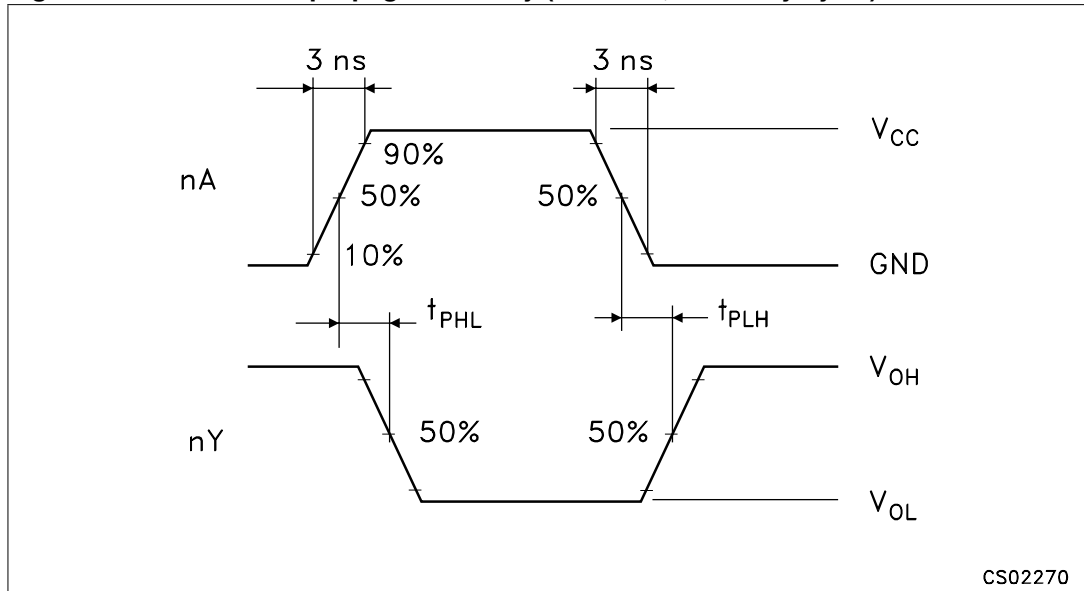

7 Package information

In order to meet environmental requirements, ST offers these devices in different grades of ECOPACK® packages, depending on their level of environmental compliance. ECOPACK specifications, grade definitions and product status are available at: www.st.com. ECOPACK is an ST trademark.

Figure 6. SO-14 package outline

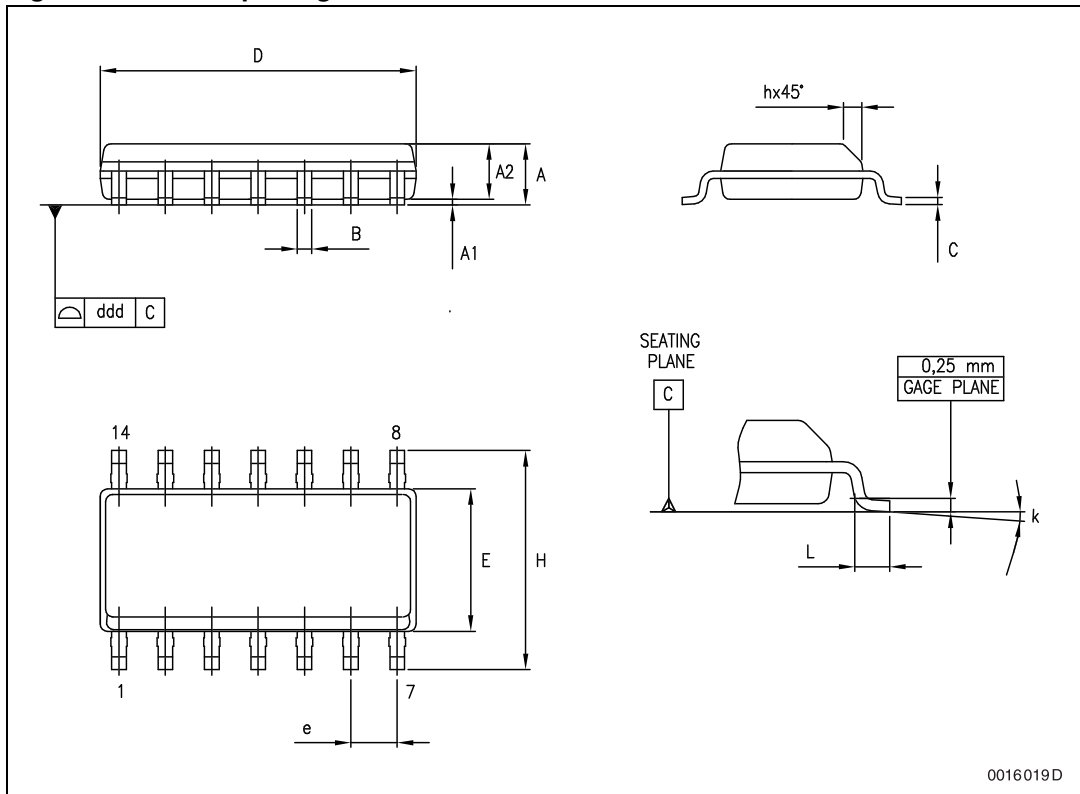

Table 10. SO-14 package mechanical data

Symbol	Dimensions					
	mm			inch		
	Min.	Typ.	Max.	Min.	Typ.	Max.
A	1.35		1.75	0.053		0.069
A1	0.1		0.25	0.004		0.010
A2	1.10		1.65	0.043		0.065
B	0.33		0.51	0.013		0.020
C	0.19		0.25	0.007		0.010
D	8.55		8.75	0.337		0.344
E	3.8		4.0	0.150		0.157
e		1.27			0.050	
H	5.8		6.2	0.228		0.244
h	0.25		0.50	0.010		0.020
L	0.4		1.27	0.016		0.050
k	0°		8°	0°		8°
ddd			0.100			0.004

Figure 7. TSSOP14 package outline

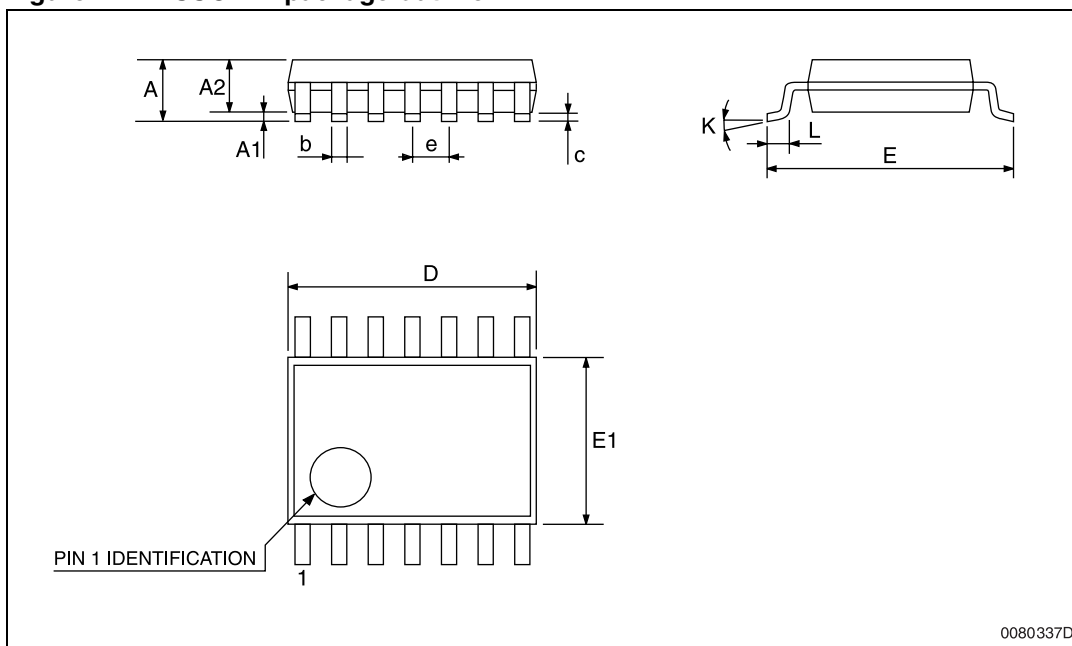
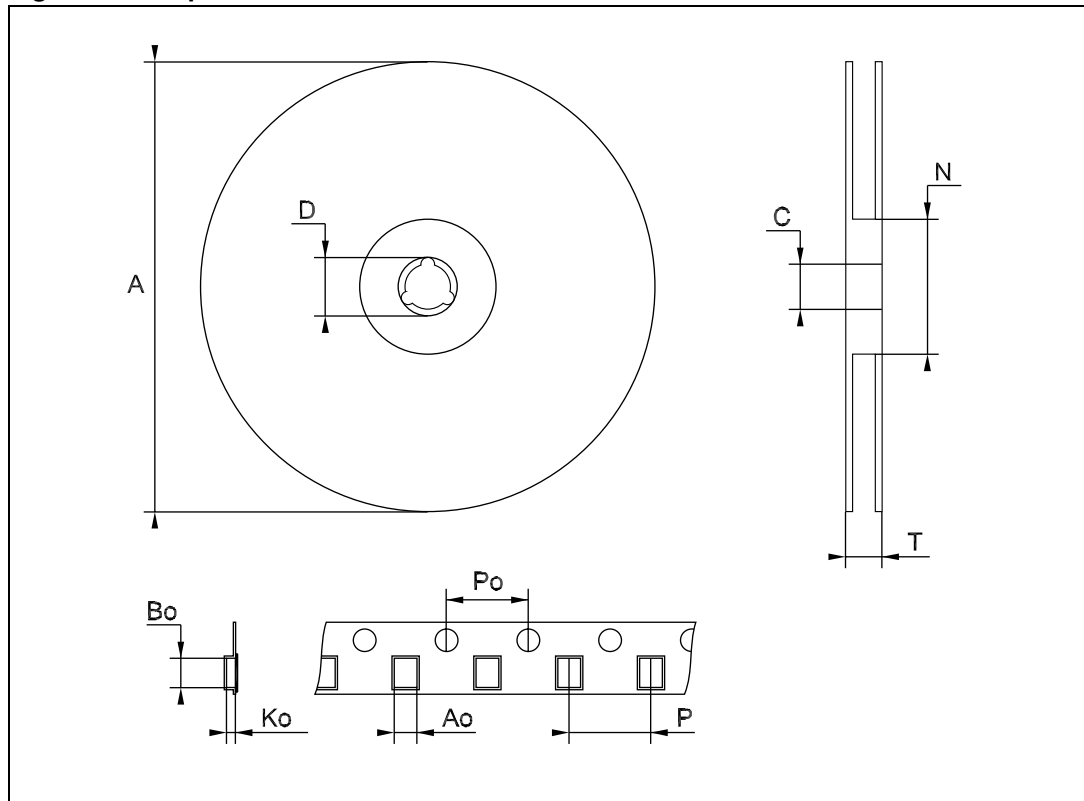

Table 11. TSSOP14 package mechanical data

Symbol	Dimensions					
	mm			inch		
	Min.	Typ.	Max.	Min.	Typ.	Max.
A			1.2			0.047
A1	0.05		0.15	0.002	0.004	0.006
A2	0.8	1	1.05	0.031	0.039	0.041
b	0.19		0.30	0.007		0.012
c	0.09		0.20	0.004		0.0089
D	4.9	5	5.1	0.193	0.197	0.201
E	6.2	6.4	6.6	0.244	0.252	0.260
E1	4.3	4.4	4.48	0.169	0.173	0.176
e		0.65 BSC			0.0256 BSC	
K	0°		8°	0°		8°
L	0.45	0.60	0.75	0.018	0.024	0.030

Figure 8. Tape and reel SO-14 outline



1. Drawing is not in scale.

Table 12. Tape and reel SO-14 mechanical data

Symbol	Dimensions					
	mm			inch		
	Min.	Typ.	Max.	Min.	Typ.	Max.
A			330			12.992
C	12.8		13.2	0.504		0.519
D	20.2			0.795		
N	60			2.362		
T			22.4			0.882
Ao	6.4		6.6	0.252		0.260
Bo	9		9.2	0.354		0.362
Ko	2.1		2.3	0.082		0.090
Po	3.9		4.1	0.153		0.161
P	7.9		8.1	0.311		0.319

Figure 9. Tape and reel TSSOP14 outline

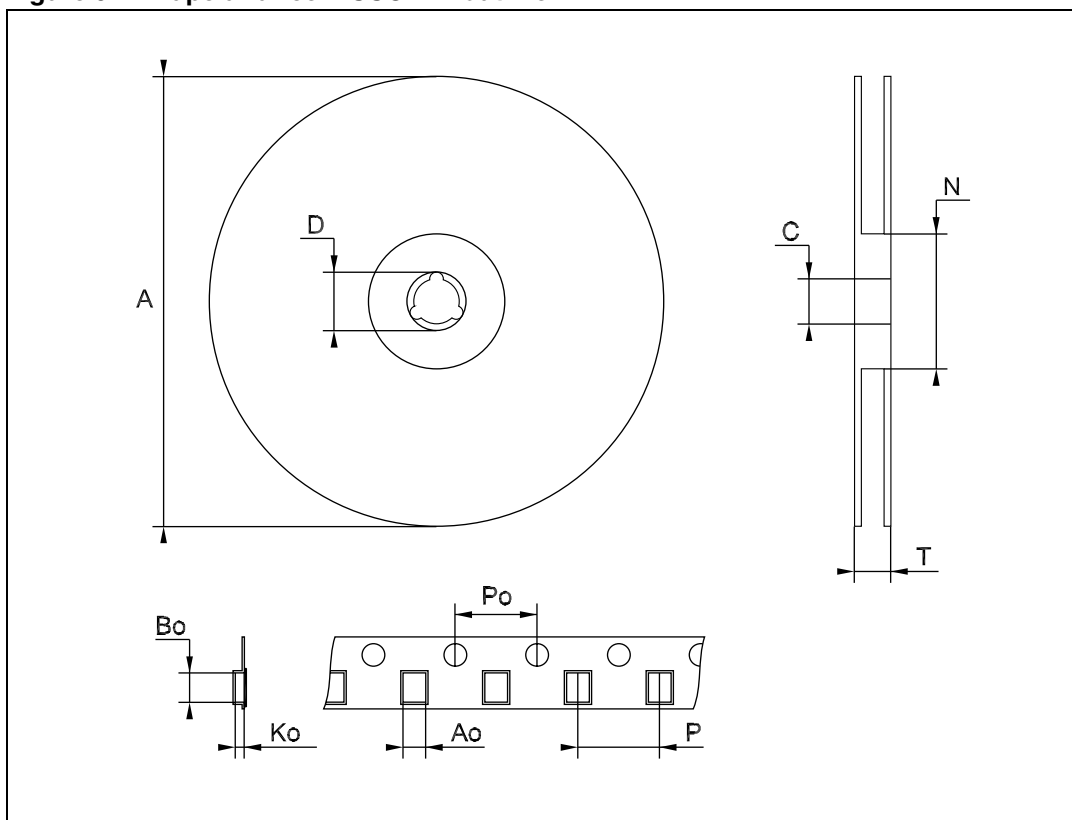

1. Drawing is not in scale.

Table 13. Tape and reel TSSOP14 mechanical data

Symbol	Dimensions					
	mm			inch		
	Min.	Typ.	Max.	Min.	Typ.	Max.
A			330			12.992
C	12.8		13.2	0.504		0.519
D	20.2			0.795		
N	60			2.362		
T			22.4			0.882
Ao	6.7		6.9	0.264		0.272
Bo	5.3		5.5	0.209		0.217
Ko	1.6		1.8	0.063		0.071
Po	3.9		4.1	0.153		0.161
P	7.9		8.1	0.311		0.319

8 Revision history

Table 14. Document revision history

Date	Revision	Changes
12-Nov-2004	6	Ordering codes revision - pag. 1
02-May-2007	7	Document reformatted, updated Table 6 on page 6
15-Jun-2012	8	Added Applications on page 1 Updated Table 1: Device summary on page 1 Updated T_{op} in Table 5: Recommended operating conditions Updated ECOPACK [®] text in Section 7: Package information Minor textual updates
03-Oct-2012	9	Added ESD performance into Features . Added 74VHC14YMTR device and "Marking" to Table 1 , updated note 1 below Table 1 . Updated Section 3: Maximum ratings (added cross-references) Reformatted Section 7: Package information . Minor corrections throughout document.