

DASH NO.	W CODE	MADE FROM
----------	--------	-----------

GSD

7772-1

REVISIONS	
ISSUE	CHANGES
3	ER 39013 DCT 3/1/4
4	CN 39245 C JLA 03/16/05
5	CN 39653 E HVN 10/04/06
6	CN 39772 C HVN 02/01/07

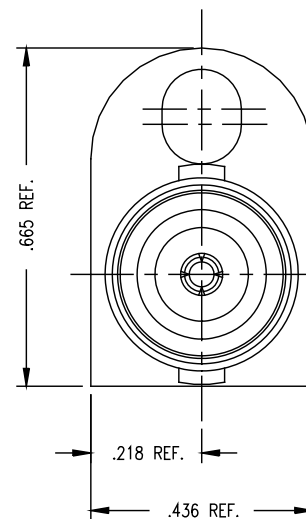
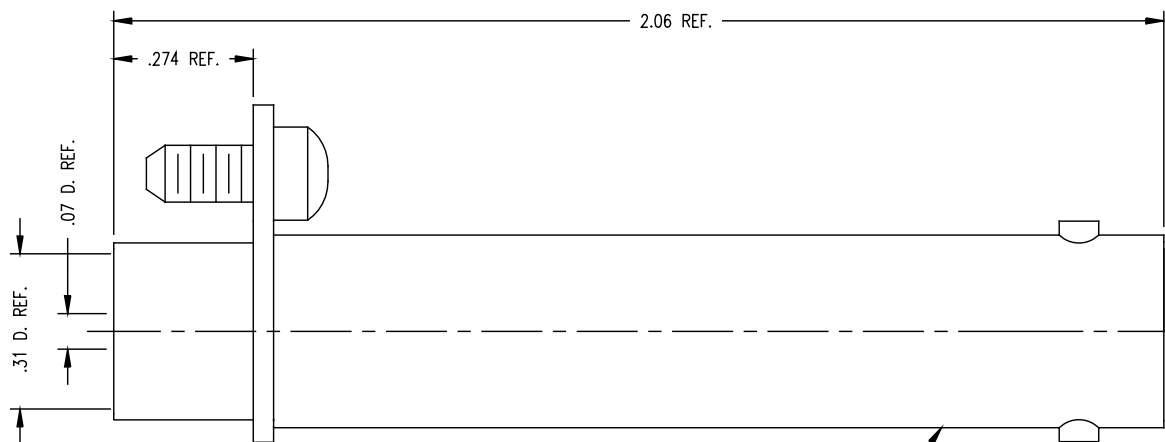

STAMP: KINGS 7772-1
YRWK (DATE CODE)

NOTES:

- BNC INTERFACE ES-17, FIG. 5.
- MATERIALS:
 - INSULATORS-MITSUI TPX, RT18 OR EQUIVALENT
 - SPRING CONTACT
 - BNC CONTACT F } BER. COP., ASTM-B-196
 - VIDEO CONTACT F }
 - HARDWARE-ZINC PLATED MACHINE SCREW
 - ALL OTHER METAL PARTS-BRASS, ASTM-B16
- FINISHES:
 - CENTER CONTACT-HARD GOLD PLATE PER MIL-G-45204
OVER NICKEL PLATE PER QQ-N-290
 - SPRING CONTACT-GOLD PLATE PER ASTM-B488
 - HARDWARE-PASSIVATE PER QQ-P-35
 - ALL OTHER METAL PARTS-KINGS TARNISH RESISTANT FINISH (TR-5)
- ELECTRIAL CHARACTERISTICS:
 - NOMINAL IMPEDANCE-75 OHMS
 - FREQUENCY RANGE- 2.4 GHZ

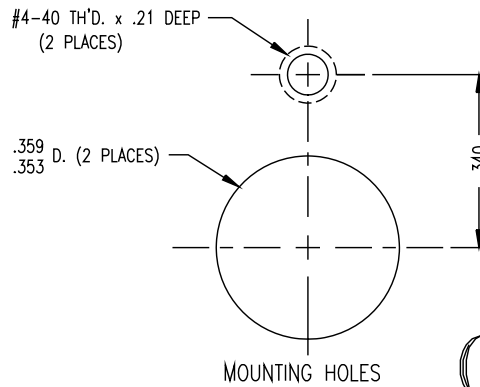

MOUNTING HOLES

GSD

7772-1 SD

SCALE	4:1		
APPROX SURFACE AREA			
WAS:	E-20178		
USED ON			
REF:	EQR 448		
ADAPTER, F-F, PANEL, MINIATURE, BNC TO VIDEO			
DRAWN	DCT	DATE	2/7/4
DESIGN	DCT	DATE	9/5/3
APPR.		DATE	
 ROCK HILL, SOUTH CAROLINA 29730			
7772-1			