

ALL DIMENSIONS IN BRACKETS ARE IN MM AND ARE FOR REFERENCE PURPOSE ONLY

8027000K001-803-C

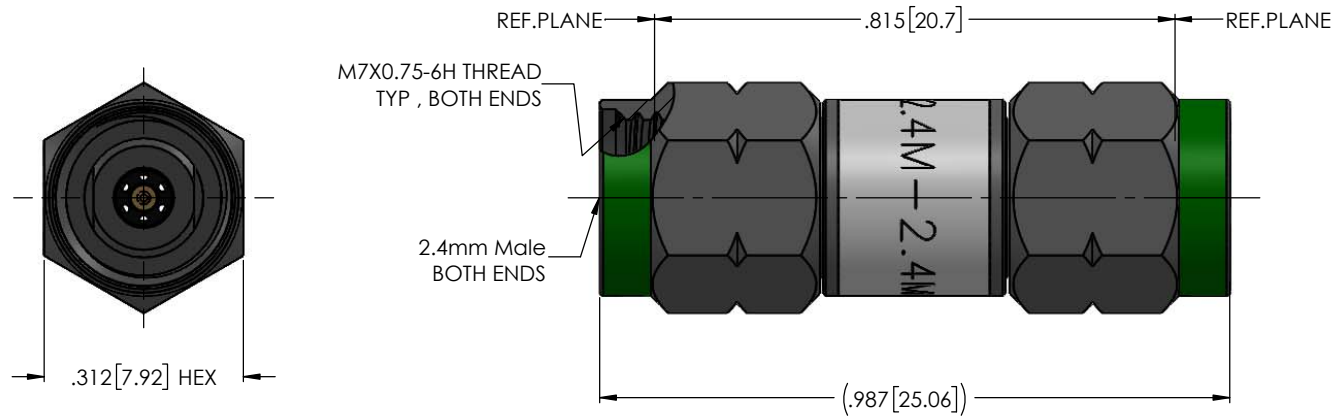

ELECTRICAL SPECIFICATIONS	
FREQUENCY RANGE	DC- 50GHz
VSWR	1.30 Max @ 50GHz
INSERTION LOSS	0.45dB Max@ 50GHz
WORKING VOLTAGE@SEA LEVEL	335 Vrms
DWV@SEA LEVEL	500 Vrms
INSULATION RESISTANCE	1000MΩ
MECHANICAL SPECIFICATIONS	
DURABILITY	500 CYCLES MIN
COUPLING NUT TORQUE - RECOMMENDED	7-10 IN.LBS[0.8 -1.1N.m]
CONTACT CAPTIVATION	≥4.5 LBS [20N]
ENVIRONMENTAL SPECIFICATIONS	
TEMP RANGE	-55° TO +125° C

NOTES:

- ASSEMBLED CONNECTOR INTERFACE IS DESIGNED IN ACCORDANCE WITH IEC61169-40(2.4mm).

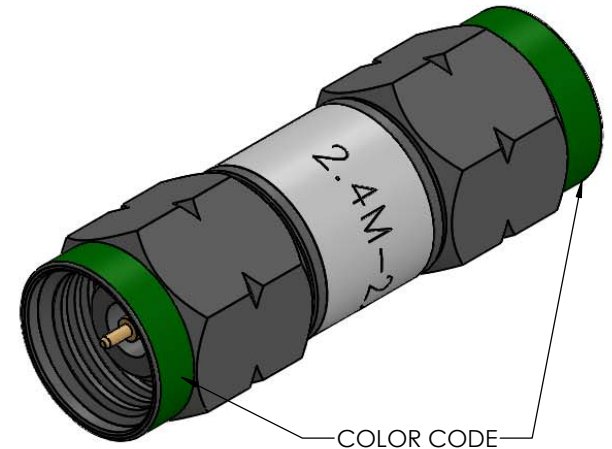

DESCRIPTION	MATERIAL	FINISH
CONTACT - HIGH FREQUENCY	BERYLLIUM COPPER PER ASTM B196, C17300, TEMPER TD04	GOLD PLATE PER ASTM B488
INSULATOR - HIGH FREQUENCY	NORYL EN265, POLYPHENYLENE OXIDE (PPO), PER ASTM D-4349 PPE220B50541 F13 G1106	N/A
BUSHING - HIGH FREQUENCY	BRASS PER ASTM B16, C36000 ALLOY, TEMPER H02	GOLD PLATE PER ASTM B488
LOCKING RING	BERYLLIUM COPPER PER ASTM B196, C17300, TEMPER TD04	N/A
COUPLING NUT	CORROSION RESISTANT STEEL PER ASTM 582, S30300, COND. A	PASSIVATE PER SAE-AMS-2700
BODY - HIGH FREQUENCY	CORROSION RESISTANT STEEL PER ASTM 582, S30300, COND. A	PASSIVATE PER SAE-AMS-2700

Table 1

UNLESS OTHERWISE SPECIFIED:		NAME	DATE	DELTA MICROWAVE ELECTRONICS (NANJING) CO., LTD	
DIMENSIONS ARE IN INCHES		DRAWN	VINCENT	8/12/2020	www.DeltaRF.com / Ph: 025-84195408/ Fax: 025-84195407
TOLERANCES:		CHECKED	JAMES	8/12/2020	
FRACTIONAL 1/64		ENG APPR.	JAMES	8/12/2020	
ANGULAR: MACH 1° BBHD 1°		COMMENTS:		TITLE:	
TWO PLACE DECIMAL .01				2.4mm MALE To 2.4mm MALE STRAIGHT ADAPTER	
THREE PLACE DECIMAL .005				SIZE	
MAX CORNER BREAK = .005				DWG. NO.	
MAX T.I.R. = .004				8027000K001-803-C	
SURFACE FINISH = A3 or BETTER				REV	
☒ DENOTES CRITICAL DIMENSION				-	
THIRD ANGLE PROJECTION				CODE ID - 00795	
MATERIAL				WEIGHT: 6.79g	
SEE TABLE				SHEET 1 OF 1	
FINISH					
SEE TABLE					
SCALE:					
FILE NAME: 8027000K001-8031-C					

PROPRIETARY AND CONFIDENTIAL  
 THE INFORMATION CONTAINED IN THIS DRAWING IS THE SOLE PROPERTY OF DELTA ELECTRONICS (NANJING) CO.LTD. ANY REPRODUCTION IN PART OR AS A WHOLE WITHOUT THE WRITTEN PERMISSION OF DELTA ELECTRONICS (NANJING) CO.LTD. IS PROHIBITED.