

MODEL 805 ACCELEROMETER



SPECIFICATIONS

- **TO-5 Series Accelerometer**
- **2-Wire IEPE Interface**
- **Low-Cost, Embedded Applications**
- **Wide Bandwidth to 12kHz**

The **Model 805** is a miniature adhesive mount IEPE accelerometer built on a 3-pin TO-5 header. It is available in $\pm 50g$ to $\pm 500g$ dynamic ranges and offers a flat frequency response to 12kHz. The accelerometer features a hermetic construction in a TO-5 header configuration. The model 805 incorporates a stable piezo-ceramic crystal and an integrated charge converter amplifier in a 100% shielded housing suitable for many embedded OEM applications.

The model 805 accelerometer is offered in two configurations; one for adhesive mounting and one for stud mounting. An isolating cover option is also included for the standard model.

FEATURES

- $\pm 50g$ to $\pm 500g$ Range
- Wide bandwidth up to 12kHz
- TO-5 Configuration
- Hermetically Sealed
- -40°C to $+100^{\circ}\text{C}$ Operating Range
- Case Grounded Design

APPLICATIONS

- Machine Monitoring
- Embedded Preventive Maintenance
- Low-Cost OEM Installation
- Permanent Structural Study
- Embedded Sensing Solution

PERFORMANCE SPECIFICATIONS

All values are typical at +24°C, 80Hz and 4mA excitation unless otherwise stated. TE Connectivity reserves the right to update and change these specifications without notice.

Parameters

DYNAMIC

				Notes
Range (g)	±50	±100	±500	
Sensitivity (mV/g)	100	50	10	±10% (see Note 1 for ±5% option)
Frequency Response (Hz)	1-8000	1-8000	1-8000	±1dB
Frequency Response (Hz)	0.3-10000	0.3-10000	0.3-12000	±3dB
Natural Frequency (Hz)	34000	34000	34000	
Non-Linearity (%FSO)	±1	±1	±1	
Transverse Sensitivity (%)	5	5	5	
Shock Limit (g)	5000	5000	5000	
Residual Noise (g RMS)	0.0004	0.0005	0.0009	Broadband 1Hz to 10kHz

ELECTRICAL

Compliance Voltage (Vdc)	18 to 30			
Excitation Current (mA)	2 to 10			
Bias Voltage (Vdc)	8 to 12			Room Temperature
Bias Voltage (Vdc)	6 to 13			-40 to +100°C
Output Impedance (Ω)	<100			
Full Scale Output Voltage (V)	±5			
Grounding	Case grounded to mounting surface			

ENVIRONMENTAL

Temperature Response (%)	±10			
Operating Temperature (°C)	-40 to +100			+120°C option, see Note 2
Storage Temperature (°C)	-54 to +125			

PHYSICAL

Sensing Element	Piezo-Ceramic			
Case Material	Stainless Steel			
Weight (grams)	5.0			
Mounting	Adhesive or Circuit Board (M3 Stud Mounting for -01 Option)			

¹ Contact factory for model number to order with ±5% sensitivity tolerance

² Contact factory for model number to order with +120°C operating temperature

Calibration supplied: CS-SENS-0100 NIST Traceable Amplitude Calibration at 80Hz

The information in this sheet has been carefully reviewed and is believed to be accurate; however, no responsibility is assumed for inaccuracies. Furthermore, this information does not convey to the purchaser of such devices any license under the patent rights to the manufacturer. TE Connectivity reserves the right to make changes without further notice to any product herein. TE Connectivity makes no warranty, representation or guarantee regarding the suitability of its product for any particular purpose, nor does TE Connectivity assume any liability arising out of the application or use of any product or circuit and specifically disclaims any and all liability, including without limitation consequential or incidental damages. Typical parameters can and do vary in different applications. All operating parameters must be validated for each customer application by customer's technical experts. TE Connectivity does not convey any license under its patent rights nor the rights of others.

MODEL 805 ACCELEROMETER

DIMENSIONS

Standard Model 805

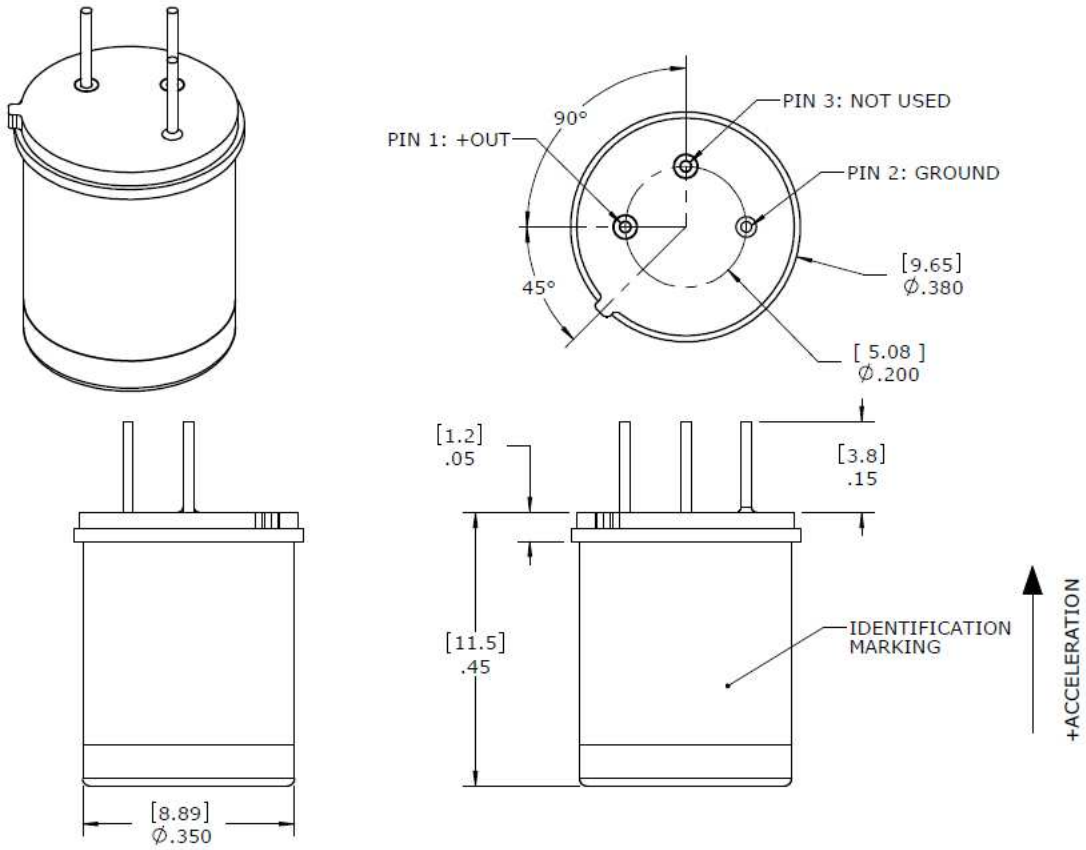

Model 805 with M3 Mounting Stud Option

