

ALL DIMENSIONS IN BRACKETS ARE IN MM AND ARE FOR REFERENCE PURPOSE ONLY

8128000K001-803-C

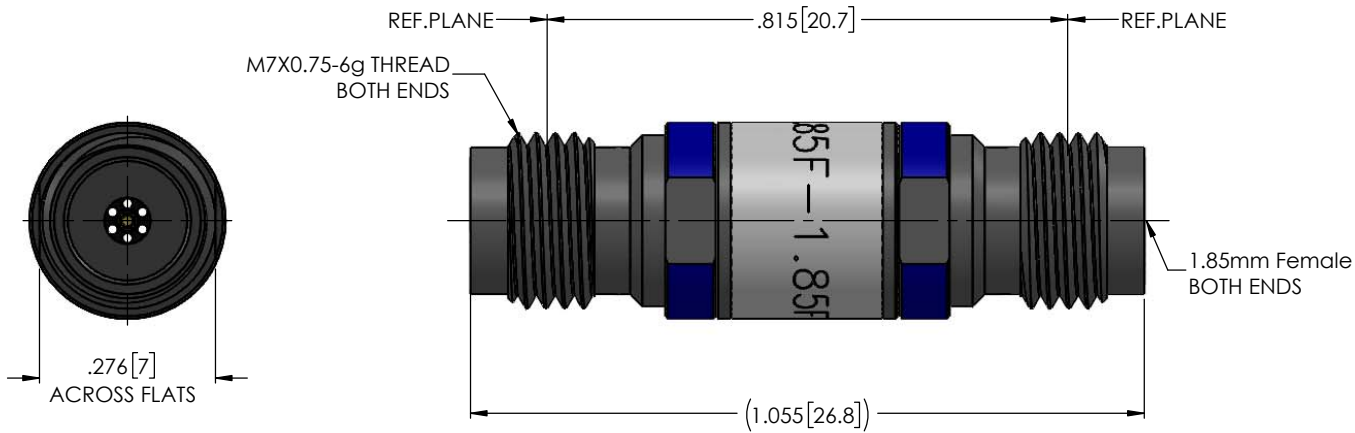

ELECTRICAL SPECIFICATIONS	
FREQUENCY RANGE	DC- 65GHz
VSWR	1.35 Max @ 65GHz
INSERTION LOSS	0.50dB Max@ 65GHz
WORKING VOLTAGE@SEA LEVEL	150 Vrms
DWV@SEA LEVEL	500 Vrms
INSULATION RESISTANCE	5000MΩ
MECHANICAL SPECIFICATIONS	
DURABILITY	500 CYCLES MIN
COUPLING NUT TORQUE - RECOMMENDED	7-10 IN.LBS[0.8 -1.1N.m]
CONTACT CAPTIVATION	≥4.5 LBS [20N]
ENVIRONMENTAL SPECIFICATIONS	
TEMP RANGE	-55° TO +125° C

NOTES:

- ASSEMBLED CONNECTOR INTERFACE IS DESIGNED IN ACCORDANCE WITH IEC61 169-32(1.85mm).

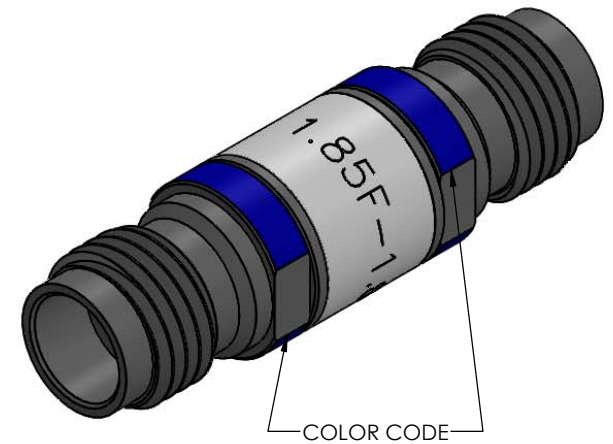

DESCRIPTION	MATERIAL	FINISH
INSULATOR - HIGH FREQUENCY	NORYL EN265, POLYPHENYLENE OXIDE (PPO), PER ASTM D-4349 PPE220B50541 F13 G1106	N/A
BUSHING - HIGH FREQUENCY	BRASS PER ASTM B16, C36000 ALLOY, TEMPER H02	GOLD PLATE PER ASTM B488
CONTACT - HIGH FREQUENCY	BERYLLIUM COPPER PER ASTM B196, C17300, TEMPER TD04	GOLD PLATE PER ASTM B488
BODY - HIGH FREQUENCY	CORROSION RESISTANT STEEL PER ASTM 582, S30300, COND. A	PASSIVATE PER SAE-AMS-2700

Table 1

**PROPRIETARY AND CONFIDENTIAL**  
 THE INFORMATION CONTAINED IN THIS DRAWING IS THE SOLE PROPERTY OF DELTA ELECTRONICS (NANJING) CO.LTD. ANY REPRODUCTION IN PART OR AS A WHOLE WITHOUT THE WRITTEN PERMISSION OF DELTA ELECTRONICS (NANJING) CO.LTD. IS PROHIBITED.  
 FILE NAME: 8128000K001-8031-C

UNLESS OTHERWISE SPECIFIED:		NAME	DATE	DELTA MICROWAVE ELECTRONICS (NANJING) CO., LTD		
DIMENSIONS ARE IN INCHES TOLERANCES: FRACTIONAL 1/64 ANGULAR: MACH 1° BBND 1° TWO PLACE DECIMAL .01 THREE PLACE DECIMAL .005 MAX CORNER BREAK = .005 MAX T.I.R. = .004 SURFACE FINISH = 63 or BETTER ☉ DENOTES CRITICAL DIMENSION		DRAWN	VINCENT	8/17/2020	www.DeltaRF.com / Ph: 025-84195408/ Fax: 025-84195407	
THIRD ANGLE PROJECTION		CHECKED	JAMES	8/17/2020	TITLE: 1.85mm FEMALE To 1.85mm FEMALE STRAIGHT ADAPTER	
MATERIAL		ENG APPR.	JAMES	8/17/2020	SIZE DWG. NO. REV	
FINISH		COMMENTS:		B 8128000K001-803-C -		
SCALE:				CODE ID- 00795 WEIGHT: 6.46g SHEET 1 OF 1		