

THIS DOCUMENT IS THE PROPERTY OF KEYSTONE ELECTRONICS CORP. AND SHALL NOT BE REPRODUCED, DISTRIBUTED OR USED AS A BASIS FOR MANUFACTURE WITHOUT PRIOR WRITTEN PERMISSION FROM KEYSTONE ELECTRONICS CORP.

REQUIRED SPACING FOR 'AAA' CLIP

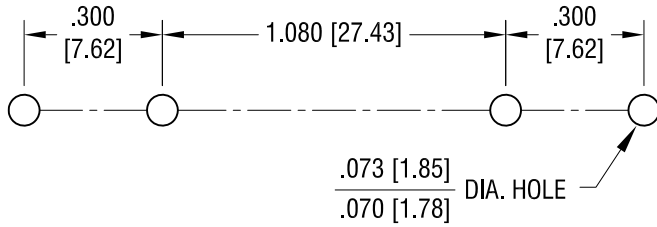

ACTUAL SIZE

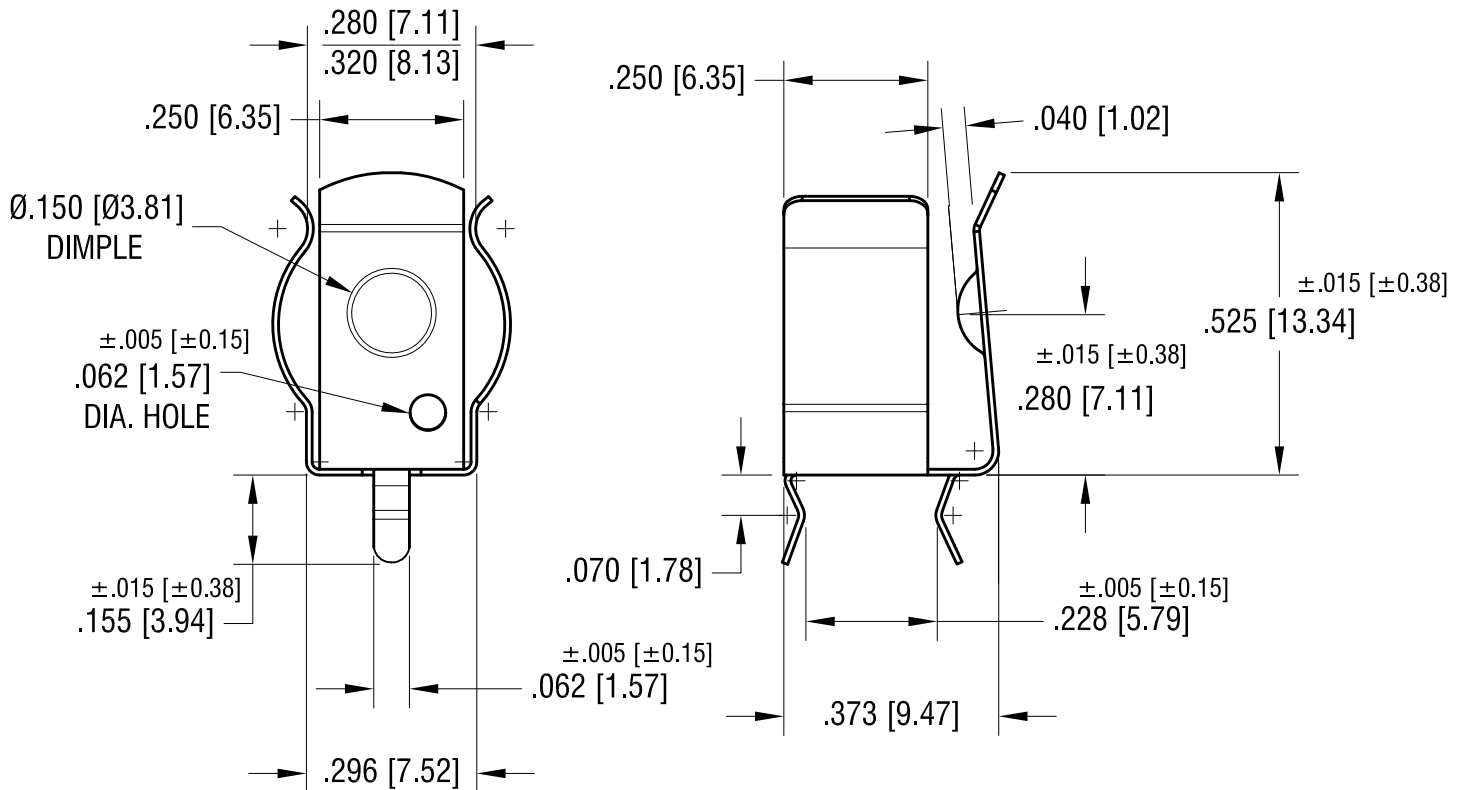
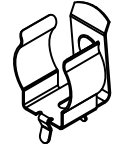

NOTE:

1. HEAT TREAT TO SPRING TEMPER.

DATE	DESCRIPTION	REV.
10.06.16	CHANGE AS PER ECR 16-063	R
10.05.15	CHANGE AS PER ECN15-112	P
7.17.14	CHANGE AS PER ECN14-069	N
6.28.13	CHANGE AS PER ECN 13-053	M
3.7.05	CHANGE AS PER ECN 05-015	L

KEYSTONE ELECTRONICS CORP.			
www.keyelco.com • ASTORIA, N.Y. 11105-2017 • Tel (718) 956-8900			
PART NAME		'AAA'-'N' PC BATTERY CLIP	
MATERIAL		.010 [.25] TH'K ANNEALED SPRING STEEL	
FINISH		DRN BY	DATE
TIN NICKEL PLATE		BOONE	2.3.98
		APP'D	SCALE
		LN	3X
TOLERANCES		CODE	
INCH [MM]		DWG NO.	
DECIMAL ±.010 [±0.25]		C	
ANGULAR ± 2°			
UNLESS OTHERWISE SPECIFIED			
		82	