

General Description

The 83PN15639 is a programmable LVPECL synthesizer that is “forward” footprint compatible with standard 5mm x 7mm oscillators. The device uses IDT’s fourth generation FemtoClock® NG technology for an optimum of high clock frequency and low phase noise performance. Forward footprint compatibility means that a board designed to accommodate the crystal oscillator interface and the optional control pins are also fully compatible with a canned oscillator footprint - the canned oscillator will drop onto the 10-VFQFN footprint for second sourcing purposes. This capability provides designers with programmability and lead time advantages of silicon/crystal based solutions while maintaining compatibility with industry standard 5mm x 7mm oscillator footprints for ease of supply chain management. Oscillator-level performance is maintained with IDT’s 4th Generation FemtoClock® NG PLL technology, which delivers sub 0.2ps RMS phase jitter.

The 83PN15639 defaults to 156.25MHz using a 25MHz crystal but can also be set to one of four different frequency multiplier settings to support a wide variety of applications. The table below shows some of the more common application settings.

Common Applications and Settings

FSEL1, FSEL0	XTAL (MHz)	Output Frequency (MHz)	Application(s)
00	25	100	PCI Express
01	25	125	Ethernet
10	25	150	SAS, Embedded Processor
11 (default)	25	156.25	10 Gigabit Ethernet (default)
11 (default)	25.000625	156.25390625	10 GbE, Frequency Margining (+25ppm)

Block Diagram

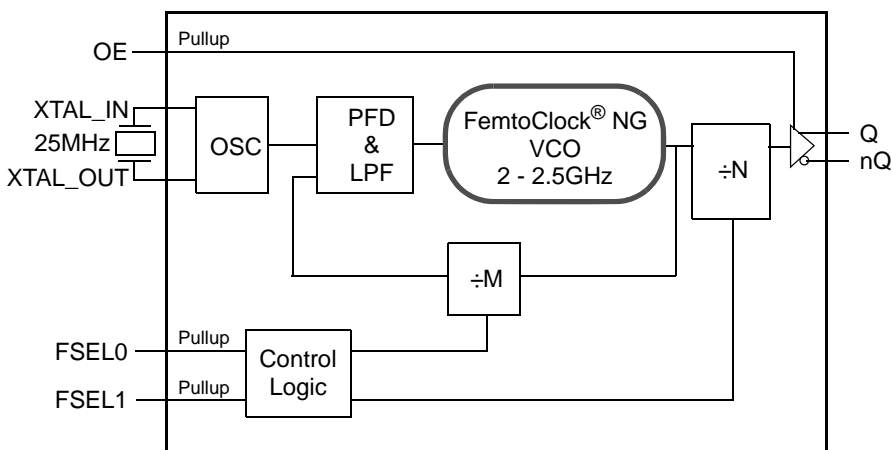

Features

- Fourth Generation FemtoClock® NG technology
- Footprint compatible with 5mm x 7mm differential oscillators
- One differential LVPECL output pair
- Crystal oscillator interface which can also be overdriven using a single-ended reference clock
- Output frequency: 100MHz - 156.25390625MHz
- Crystal/input frequency: 25MHz, 12pF parallel resonant crystal
- VCO range: 2GHz – 2.5GHz
- RMS phase jitter @ 156.25MHz, 10kHz – 1MHz: 0.179ps (typical)
- Full 3.3V or 2.5V operating supply
- -40°C to 85°C ambient operating temperature
- Lead-free (RoHS 6) packaging

Pin Assignment

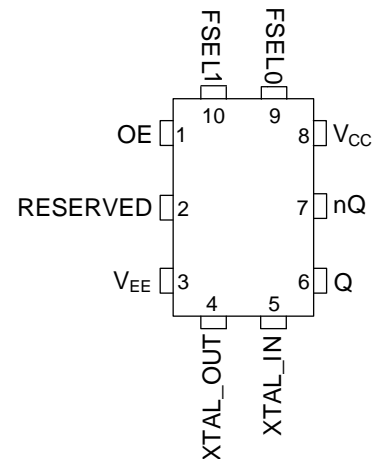

83PN15639
10-Lead VFQFN
5mm x 7mm x 1mm
package body
NR Package
Top View

Pin Descriptions and Characteristics

Table 1. Pin Descriptions

Number	Name	Type		Description
1	OE	Input	Pullup	Output enable. LVCMOS/LVTTL interface levels.
2	RESERVED	Reserve		Reserved pin. Do not connect.
3	V _{EE}	Power		Negative supply pin.
4, 5	XTAL_OUT XTAL_IN	Input		Crystal oscillator interface XTAL_IN is the input, XTAL_OUT is the output.
6, 7	Q, nQ	Output		Differential output pair. LVPECL interface levels.
8	V _{CC}	Power		Power supply pin.
9	FSEL0	Input	Pullup	Output divider control inputs. Sets the output divider value to one of four values. LVCMOS/LVTTL interface levels.
10	FSEL1	Input	Pullup	Output divider control inputs. Sets the output divider value to one of four values. LVCMOS/LVTTL interface levels.

NOTE: *Pullup* refers to internal input resistors. See Table 2, *Pin Characteristics*, for typical values.

Table 2. Pin Characteristics

Symbol	Parameter	Test Conditions	Minimum	Typical	Maximum	Units
C _{IN}	Input Capacitance	OE, FSEL0, FSEL1		3.5		pF
R _{PULLUP}	Input Pullup Resistor			51		kΩ

Absolute Maximum Ratings

NOTE: Stresses beyond those listed under *Absolute Maximum Ratings* may cause permanent damage to the device. These ratings are stress specifications only. Functional operation of product at these conditions or any conditions beyond those listed in the *DC Characteristics* or *AC Characteristics* is not implied. Exposure to absolute maximum rating conditions for extended periods may affect product reliability.

Item	Rating
Supply Voltage, V_{CC}	3.63V
Inputs, V_I XTAL_IN Other Inputs	0V to 2V -0.5V to $V_{CC} + 0.5V$
Outputs, I_O Continuous Current Surge Current	50mA 100mA
Package Thermal Impedance, θ_{JA}	36.8°C/W (0 mps)
Storage Temperature, T_{STG}	-65°C to 150°C

DC Electrical Characteristics

Table 4A. Power Supply DC Characteristics, $V_{CC} = 3.3V \pm 5\%$, $V_{EE} = 0V$, $T_A = -40^\circ C$ to $85^\circ C$

Symbol	Parameter	Test Conditions	Minimum	Typical	Maximum	Units
V_{CC}	Power Supply Voltage		3.135	3.3	3.465	V
I_{EE}	Power Supply Current			120	140	mA

Table 4B. Power Supply DC Characteristics, $V_{CC} = 2.5V \pm 5\%$, $V_{EE} = 0V$, $T_A = -40^\circ C$ to $85^\circ C$

Symbol	Parameter	Test Conditions	Minimum	Typical	Maximum	Units
V_{CC}	Power Supply Voltage		2.375	2.5	2.625	V
I_{EE}	Power Supply Current			117	135	mA

Table 4C. LVCMOS/LVTTL DC Characteristics, $V_{CC} = 3.3V \pm 5\%$ or $2.5V \pm 5\%$, $V_{EE} = 0V$, $T_A = -40^\circ C$ to $85^\circ C$

Symbol	Parameter	Test Conditions	Minimum	Typical	Maximum	Units
V_{IH}	Input High Voltage	$V_{CC} = 3.465V$	2		$V_{CC} + 0.3$	V
		$V_{CC} = 2.625V$	1.7		$V_{CC} + 0.3$	V
V_{IL}	Input Low Voltage	$V_{CC} = 3.465V$	-0.3		0.8	V
		$V_{CC} = 2.625V$	-0.3		0.7	V
I_{IH}	Input High Current	OE, FSEL[1:0] $V_{CC} = V_{IN} = 3.465V$ or $2.625V$			5	μA
I_{IL}	Input Low Current	OE, FSEL[1:0] $V_{CC} = 3.465V$ or $2.625V$, $V_{IN} = 0V$	-150			μA

Table 4D. LVPECL DC Characteristics, $V_{CC} = 3.3V \pm 5\%$ or $2.5V \pm 5\%$, $V_{EE} = 0V$, $T_A = -40^\circ C$ to $85^\circ C$

Symbol	Parameter	Test Conditions	Minimum	Typical	Maximum	Units
V_{OH}	Output High Voltage; NOTE 1		$V_{CC} - 1.3$		$V_{CC} - 0.8$	V
V_{OL}	Output Low Voltage; NOTE 1		$V_{CC} - 2.0$		$V_{CC} - 1.6$	V
V_{SWING}	Peak-to-Peak Output Voltage Swing		0.5		1.0	V

NOTE 1: Outputs termination with 50Ω to $V_{CC} - 2V$.

Table 5. Crystal Characteristics

Parameter	Test Conditions	Minimum	Typical	Maximum	Units
Mode of Oscillation		Fundamental			
Frequency			25		MHz
			25.000625		MHz
Equivalent Series Resistance (ESR)				50	Ω
Shunt Capacitance				7	pF

AC Electrical Characteristics

Table 6. AC Characteristics, $V_{CC} = 3.3V \pm 5\%$ or $2.5V \pm 5\%$, $V_{EE} = 0V$, $T_A = -40^{\circ}C$ to $85^{\circ}C$

Symbol	Parameter	Test Conditions	Minimum	Typical	Maximum	Units
f_{OUT}	Output Frequency		100		156.25390625	MHz
$f_{jit}(\emptyset)$	RMS Phase Jitter (Random); NOTE 1	156.25MHz, Integration Range: 10kHz – 1MHz		0.179	0.220	ps
		150MHz, Integration Range: 12kHz – 20MHz		0.249	0.316	ps
		125MHz, Integration Range: 12kHz – 20MHz		0.241	0.306	ps
		100MHz, Integration Range: 12kHz – 20MHz		0.249	0.316	ps
$f_{jit}(cc)$	Cycle-to-Cycle Jitter; NOTE 2				20	ps
t_R / t_F	Output Rise/Fall Time	20% to 80%	100		400	ps
odc	Output Duty Cycle		48		52	%

NOTE: Electrical parameters are guaranteed over the specified ambient operating temperature range, which is established when the device is mounted in a test socket with maintained transverse airflow greater than 500 lfm. The device will meet specifications after thermal equilibrium has been reached under these conditions.

NOTE: Characterized using a 25MHz, 12pF resonant crystal.

NOTE 1: Please refer to the Phase Noise plots.

NOTE 2: This parameter is defined in accordance with JEDEC Standard 65.

Parameter Measurement Information

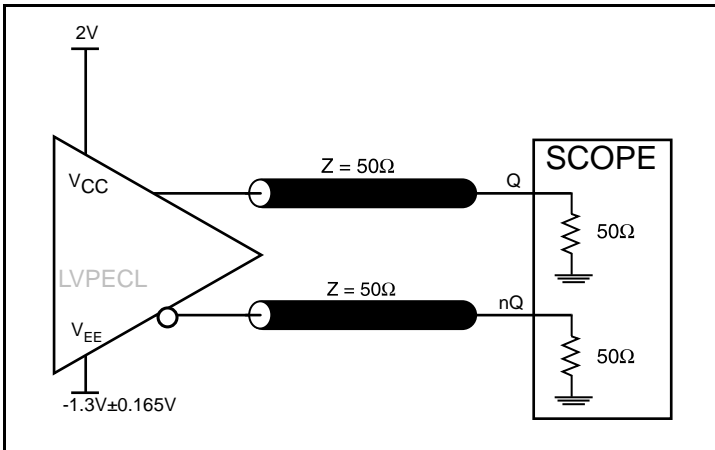

3.3V LVPECL Output Load AC Test Circuit

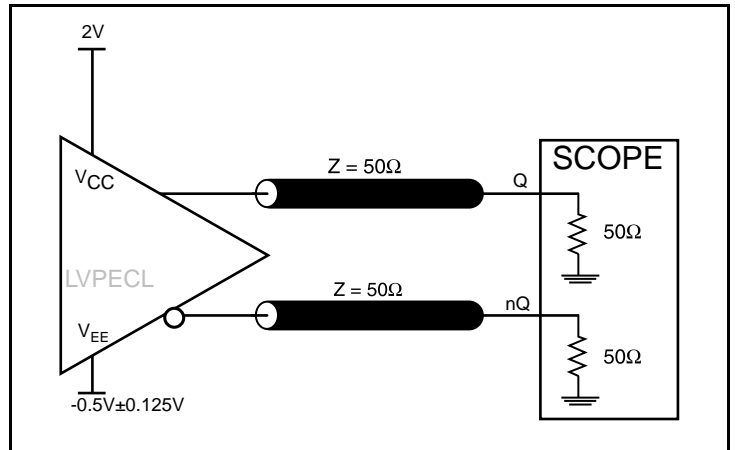

2.5V LVPECL Output Load AC Test Circuit

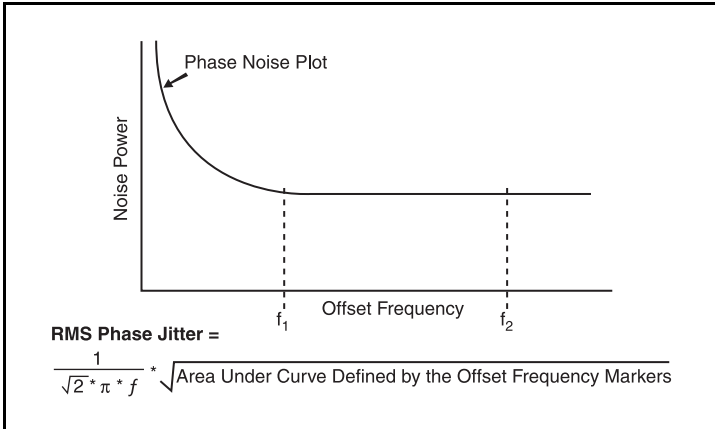

RMS Phase Jitter

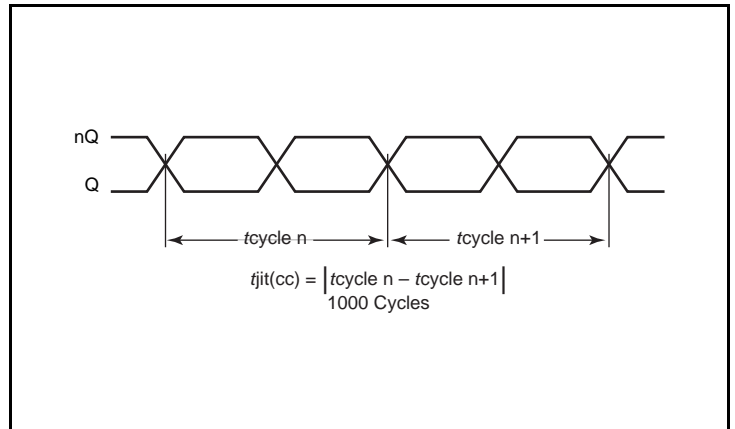

Cycle-to-Cycle Jitter

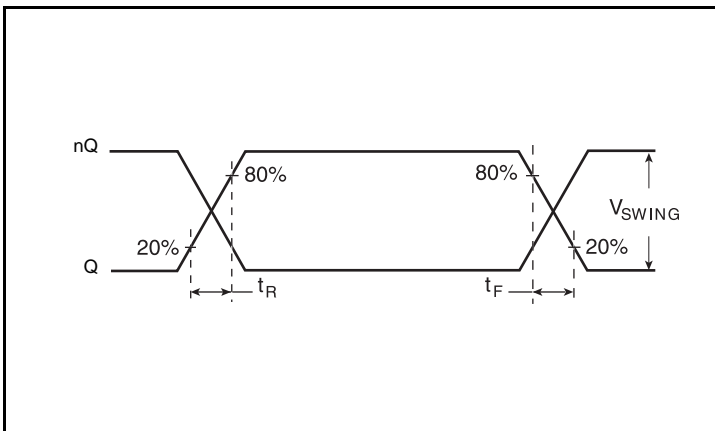

Output Rise/Fall Time

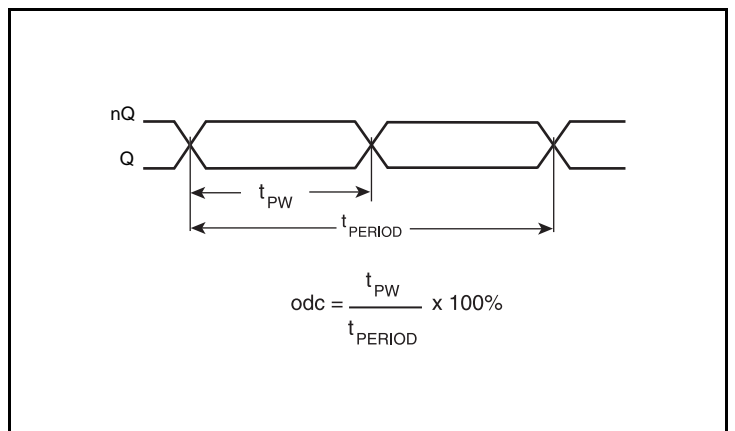

Output Duty Cycle/Pulse Width/Period

Applications Information

Recommendations for Unused Input Pins

Inputs:

LVC MOS Control Pins

All control pins have internal pullup resistor; additional resistance is not required but can be added for additional protection. A 1kΩ resistor can be used.

VFQFN EPAD Thermal Release Path

In order to maximize both the removal of heat from the package and the electrical performance, a land pattern must be incorporated on the Printed Circuit Board (PCB) within the footprint of the package corresponding to the exposed metal pad or exposed heat slug on the package, as shown in *Figure 1*. The solderable area on the PCB, as defined by the solder mask, should be at least the same size/shape as the exposed pad/slug area on the package to maximize the thermal/electrical performance. Sufficient clearance should be designed on the PCB between the outer edges of the land pattern and the inner edges of pad pattern for the leads to avoid any shorts.

While the land pattern on the PCB provides a means of heat transfer and electrical grounding from the package to the board through a solder joint, thermal vias are necessary to effectively conduct from the surface of the PCB to the ground plane(s). The land pattern must be connected to ground through these vias. The vias act as “heat pipes”. The number of vias (i.e. “heat pipes”) are application specific and dependent upon the package power dissipation as well as electrical conductivity requirements. Thus, thermal and electrical analysis and/or testing are recommended to determine the minimum number needed. Maximum thermal and electrical performance is achieved when an array of vias is incorporated in the land pattern. It is recommended to use as many vias connected to ground as possible. It is also recommended that the via diameter should be

12mils to 13mils (0.30mm to 0.33mm) with 1oz copper via barrel plating. This is desirable to avoid any solder wicking inside the via during the soldering process which may result in voids in solder between the exposed pad/slug and the thermal land. Precautions should be taken to eliminate any solder voids between the exposed heat slug and the land pattern. Note: These recommendations are to be used as a guideline only. For further information, please refer to the Application Note on the Surface Mount Assembly of Amkor’s Thermally/ Electrically Enhance Leadframe Base Package, Amkor Technology.

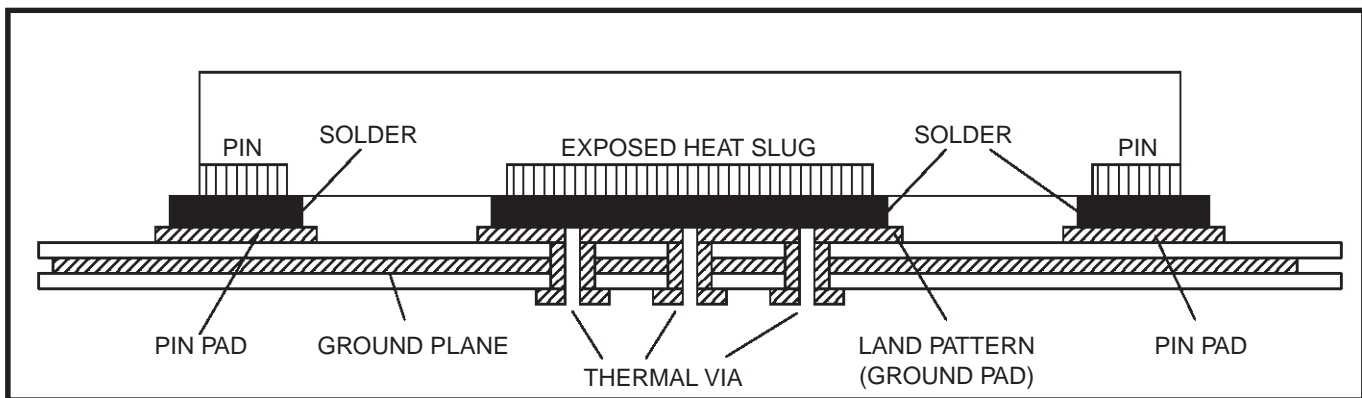

Figure 1. P.C. Assembly for Exposed Pad Thermal Release Path – Side View (drawing not to scale)

Overdriving the XTAL Interface

The XTAL_IN input can be overdriven by an LVCMOS driver or by one side of a differential driver through an AC coupling capacitor. The XTAL_OUT pin can be left floating. The amplitude of the input signal should be between 500mV and 1.8V and the slew rate should not be less than 0.2V/nS. For 3.3V LVCMOS inputs, the amplitude must be reduced from full swing to at least half the swing in order to prevent signal interference with the power rail and to reduce internal noise. *Figure 2A* shows an example of the interface diagram for a high speed 3.3V LVCMOS driver. This configuration requires that the sum of the output impedance of the driver (R_o) and the series resistance (R_s) equals the transmission line impedance. In addition, matched termination at the crystal input will attenuate the signal in half. This can be done in one of two ways. First, R_1 and R_2 in parallel should equal the transmission line impedance. For most 50Ω applications, R_1 and R_2 can be 100Ω. This can also be accomplished by removing R_1 and changing R_2 to 50Ω. The values of the resistors can be increased to reduce the loading for a slower and weaker LVCMOS driver. *Figure 2B* shows an example of the interface diagram for an LVPECL driver. This is a standard LVPECL termination with one side of the driver feeding the XTAL_IN input. It is recommended that all components in the schematics be placed in the layout. Though some components might not be used, they can be utilized for debugging purposes. The datasheet specifications are characterized and guaranteed by using a quartz crystal as the input.

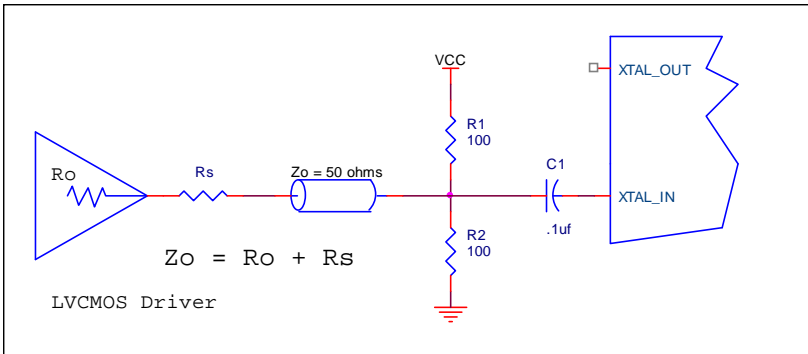

Figure 2A. General Diagram for LVCMOS Driver to XTAL Input Interface

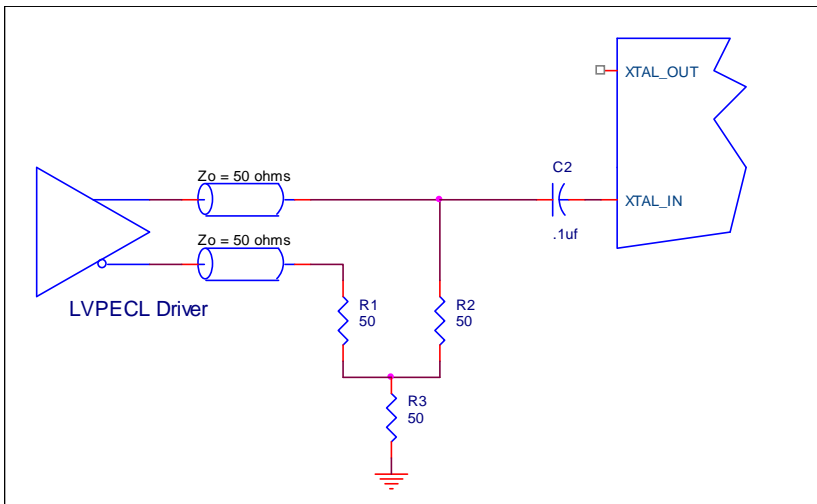

Figure 2B. General Diagram for LVPECL Driver to XTAL Input Interface

Termination for 3.3V LVPECL Outputs

The clock layout topology shown below is a typical termination for LVPECL outputs. The two different layouts mentioned are recommended only as guidelines.

The differential outputs are low impedance follower outputs that generate ECL/LVPECL compatible outputs. Therefore, terminating resistors (DC current path to ground) or current sources must be used for functionality. These outputs are designed to drive 50Ω transmission lines. Matched impedance techniques should be used to maximize operating frequency and minimize signal distortion. *Figures 3A and 3B* show two different layouts which are recommended only as guidelines. Other suitable clock layouts may exist and it would be recommended that the board designers simulate to guarantee compatibility across all printed circuit and clock component process variations.

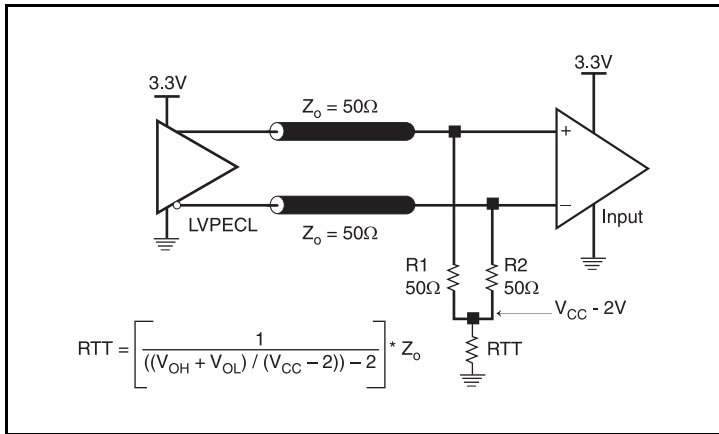

Figure 3A. 3.3V LVPECL Output Termination

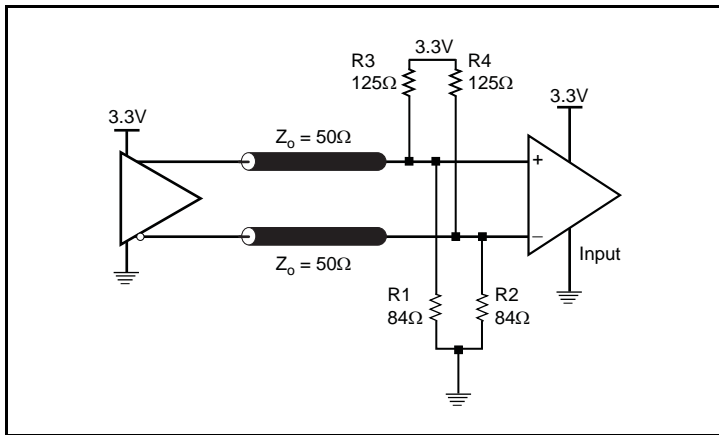

Figure 3B. 3.3V LVPECL Output Termination

Termination for 2.5V LVPECL Outputs

Figure 4A and Figure 4B show examples of termination for 2.5V LVPECL driver. These terminations are equivalent to terminating 50Ω to $V_{CC} - 2V$. For $V_{CC} = 2.5V$, the $V_{CC} - 2V$ is very close to ground level. The R3 in Figure 4B can be eliminated and the termination is shown in Figure 4C.

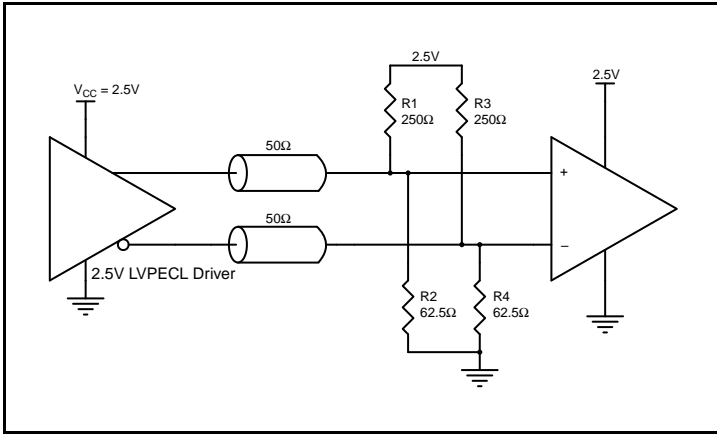

Figure 4A. 2.5V LVPECL Driver Termination Example

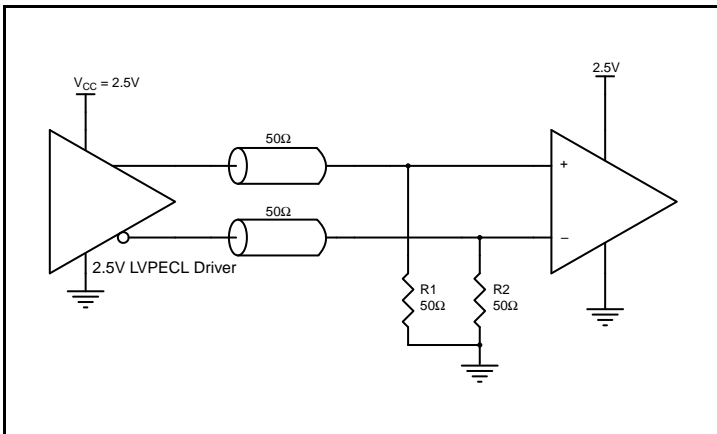

Figure 4C. 2.5V LVPECL Driver Termination Example

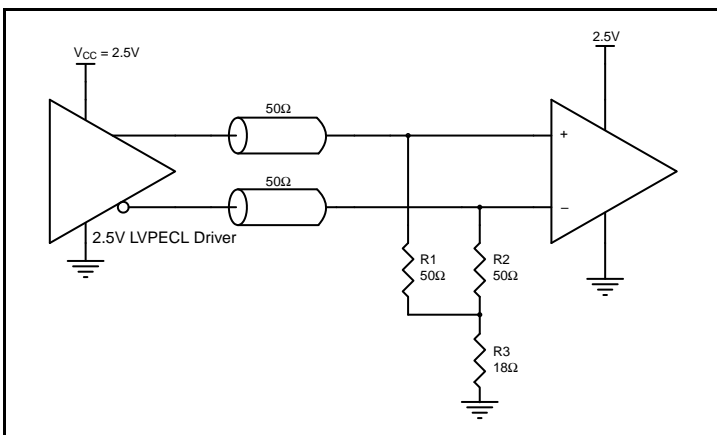

Figure 4B. 2.5V LVPECL Driver Termination Example

Schematic Example

Figure 5 shows an example 83PN15639 application schematic in which the device is operated at $V_{CC} = +3.3V$. The schematic example focuses on functional connections and is intended as an example only and may not represent the exact user configuration. Refer to the pin description and functional tables in the datasheet to ensure the logic control inputs are properly set. For example OE and FSEL[1:0] can be configured from an FPGA instead of set with pull up and pull down resistors as shown.

As with any high speed analog circuitry, the power supply pins are vulnerable to random noise, so to achieve optimum jitter performance isolation of the V_{CC} pin from power supply is required. In order to achieve the best possible filtering, it is recommended that the placement of the filter components be on the device side of the PCB as close to the power pins as possible. If space is limited, the $0.1\mu F$ capacitor on the V_{CC} pin must be placed on the device side with direct return to the ground plane through vias. The remaining filter components can be on the opposite side of the PCB.

Power supply filter component recommendations are a general guideline to be used for reducing external noise from coupling into the devices. The filter performance is designed for a wide range of noise frequencies. This low-pass filter starts to attenuate noise at approximately 10kHz. If a specific frequency noise component is known, such as switching power supplies frequencies, it is recommended that component values be adjusted and if required, additional filtering be added. Additionally, good general design practices for power plane voltage stability suggests adding bulk capacitance in the local area of all devices.

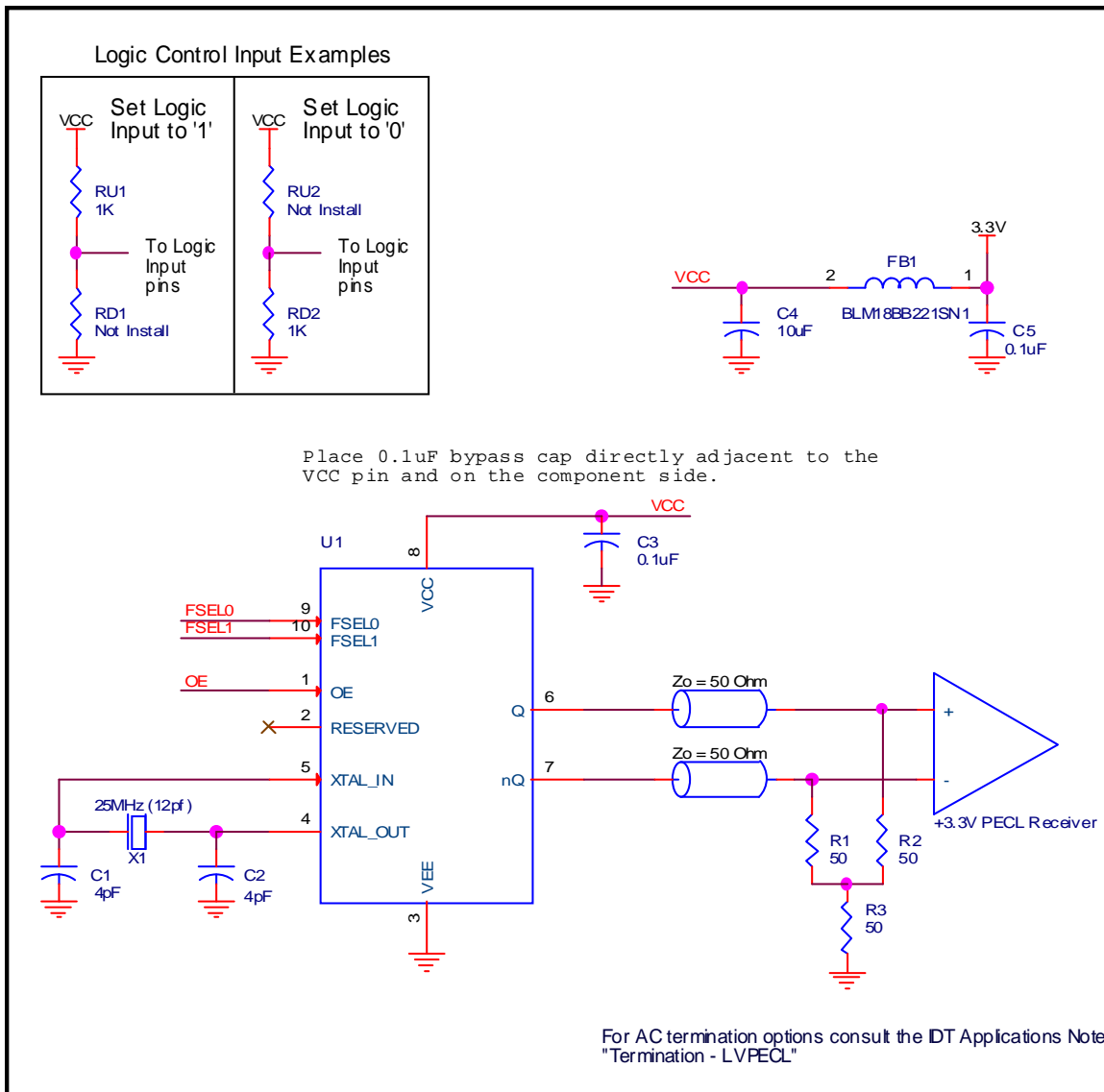

Figure 5. 83PN15639 Application Schematic

Power Considerations

This section provides information on power dissipation and junction temperature for the 83PN15639. Equations and example calculations are also provided.

1. Power Dissipation.

The total power dissipation for the 83PN15639 is the sum of the core power plus the power dissipation due to the load. The following is the power dissipation for $V_{CC} = 3.3V + 5\% = 3.465V$, which gives worst case results.

NOTE: Please refer to Section 3 for details on calculating power dissipation due to the load.

- Power (core)_{MAX} = $V_{CC_MAX} * I_{EE_MAX} = 3.465V * 140mA = \mathbf{485.1mW}$
- Power (outputs)_{MAX} = **32mW/Loaded Output pair**

Total Power_{MAX} (3.465V, with all outputs switching) = 485.1mW + 32mW = **517.1mW**

2. Junction Temperature.

Junction temperature, T_j , is the temperature at the junction of the bond wire and bond pad, and directly affects the reliability of the device. The maximum recommended junction temperature is 125°C. Limiting the internal transistor junction temperature, T_j , to 125°C ensures that the bond wire and bond pad temperature remains below 125°C.

The equation for T_j is as follows: $T_j = \theta_{JA} * Pd_total + T_A$

T_j = Junction Temperature

θ_{JA} = Junction-to-Ambient Thermal Resistance

Pd_total = Total Device Power Dissipation (example calculation is in section 1 above)

T_A = Ambient Temperature

In order to calculate junction temperature, the appropriate junction-to-ambient thermal resistance θ_{JA} must be used. Assuming no air flow and a multi-layer board, the appropriate value is 36.8°C/W per Table 7 below.

Therefore, T_j for an ambient temperature of 85°C with all outputs switching is:

$$85^\circ\text{C} + 0.517\text{W} * 36.8^\circ\text{C/W} = 104^\circ\text{C}. \text{ This is below the limit of } 125^\circ\text{C}.$$

This calculation is only an example. T_j will obviously vary depending on the number of loaded outputs, supply voltage, air flow and the type of board (multi-layer).

Table 7. Thermal Resistance θ_{JA} for 10-Lead VFQFN, Forced Convection

Meters per Second	θ_{JA} by Velocity		
	0	1	2
Multi-Layer PCB, JEDEC Standard Test Boards	36.8°C/W	31.7°C/W	30.1°C/W

3. Calculations and Equations.

The purpose of this section is to calculate the power dissipation for the LVPECL output pair.

The LVPECL output driver circuit and termination are shown in *Figure 6*.

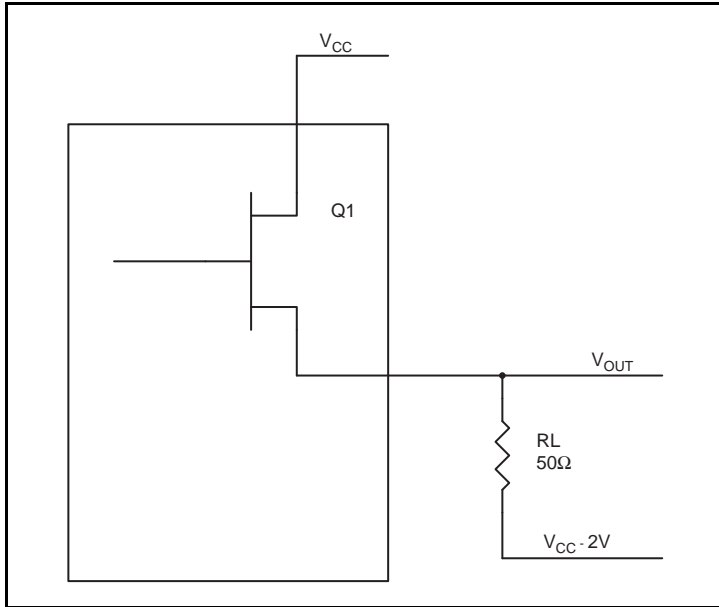

Figure 6. LVPECL Driver Circuit and Termination

To calculate power dissipation due to the load, use the following equations which assume a 50Ω load, and a termination voltage of $V_{CC} - 2V$.

- For logic high, $V_{OUT} = V_{OH_MAX} = V_{CC_MAX} - 0.8V$
 $(V_{CC_MAX} - V_{OH_MAX}) = 0.8V$
- For logic low, $V_{OUT} = V_{OL_MAX} = V_{CC_MAX} - 1.6V$
 $(V_{CC_MAX} - V_{OL_MAX}) = 1.6V$

Pd_H is power dissipation when the output drives high.

Pd_L is the power dissipation when the output drives low.

$$Pd_H = [(V_{OH_MAX} - (V_{CC_MAX} - 2V))/R_L] * (V_{CC_MAX} - V_{OH_MAX}) = [(2V - (V_{CC_MAX} - V_{OH_MAX}))/R_L] * (V_{CC_MAX} - V_{OH_MAX}) = [(2V - 0.8V)/50\Omega] * 0.8V = \mathbf{19.2mW}$$

$$Pd_L = [(V_{OL_MAX} - (V_{CC_MAX} - 2V))/R_L] * (V_{CC_MAX} - V_{OL_MAX}) = [(2V - (V_{CC_MAX} - V_{OL_MAX}))/R_L] * (V_{CC_MAX} - V_{OL_MAX}) = [(2V - 1.6V)/50\Omega] * 1.6V = \mathbf{12.8mW}$$

$$\text{Total Power Dissipation per output pair} = Pd_H + Pd_L = \mathbf{32mW}$$

Reliability Information

Table 8. θ_{JA} vs. Air Flow Table for a 10-Lead VFQFN

θ_{JA} vs. Air Flow			
Meters per Second	0	1	2
Multi-Layer PCB, JEDEC Standard Test Boards	36.8°C/W	31.7°C/W	30.1°C/W

Transistor Count

The transistor count for 83PN15639 is: 47,515

10-Lead VFQFN, NR Suffix Package Outline

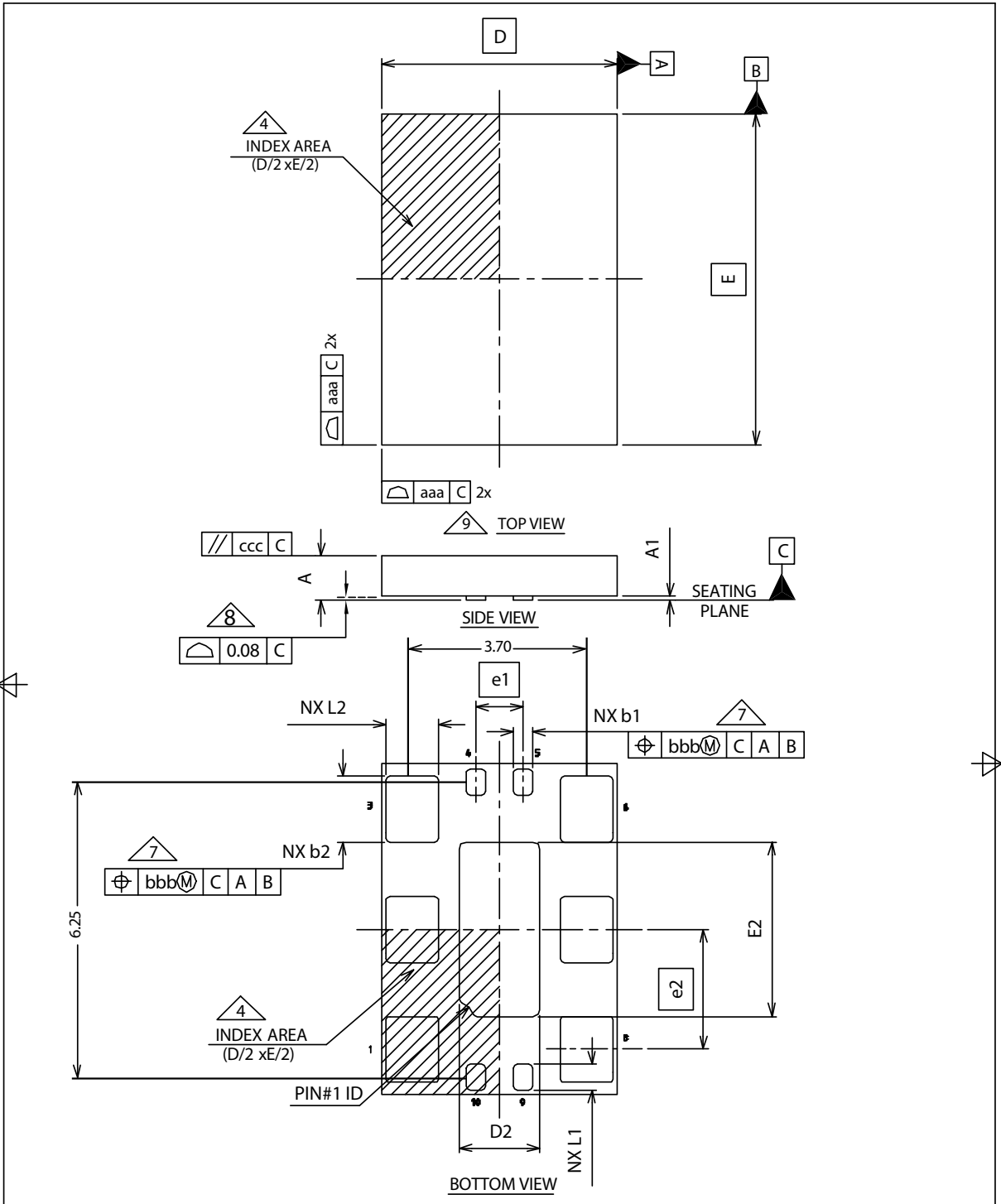

FOR REVISION UPDATE PLEASE REFER TO HISTORY OF CHANGES.

DRAFT 1	ORIGINATOR	ZAHRUL		DWG. NO : PKGML00305
	ENGINEERING MANAGER			MLP QUAD PACKAGE OUTLINE 5.00x7.00 MLPQ 10LD 1.00/2.54 Pitch
	TOOLING MANAGER	ARAVEN		
	TECH. SALES MANAGER	KANDA		
	DATE	2007-APR-18		
			Page 1 Of 4	

10-Lead VFQFN, NR Suffix Package Outline, continued

COMMON DIMENSION						
TOLERANCE OF FORM AND POSITION						
aaa	0.15					
bbb	0.10					
ccc	0.10					

COMMON DIMENSION			
SYMBOL	V : Very thin		
	MIN	NOM	MAX
A	0.80	0.90	1.00
A1	0.00	0.02	0.05
NOTES	1, 2	1, 2	1, 2



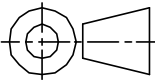

Summary Table				
Lead Pitch (e1 & e2)	Lead Count	Body Size	Very Very Thin Variation	Pin #1 ID
1.00/2.54	10	5.00X7.00	VNJR-1	R0.30

FOR REVISION UPDATE PLEASE REFER TO HISTORY OF CHANGES.

DRAFT 1	ORIGINATOR	ZAHRUL		DWG. NO : PKGML00305
	ENGINEERING MANAGER			MLP QUAD PACKAGE OUTLINE 5.00x7.00 MLPQ 10LD 1.00/2.54 Pitch
	TOOLING MANAGER	ARAVEN		
	TECH. SALES MANAGER	KANDA		
	DATE	2007-APR-18		
			PAGE: 2 of 4	

10-Lead VFQFN, NR Suffix Package Outline, continued

NOTE:

1. Dimensioning and tolerancing conform to ASME Y14.5M-1994.
2. All dimensions are in millimeters, angles are in degrees(°).
3. N is the total number of terminals.
4.  The location of the terminal #1 identifier and terminal numbering convention conforms to JEDEC publication 95 SPP-002.
5. ND and NE refer to the number of terminals on each D and E side respectively.
6. NJR refers to NON JEDEC REGISTERED
7.  Dimension b applies to metallized terminal and is measured between 0.10mm and 0.30mm from the terminal tip. If the terminal has the optional radius on the other end of the terminal, the dimension b should not be measured in that radius area.
8.  Coplanarity applies to the terminals and all other bottom surface metallization.
9.  Drawing shown are for illustration only.

FOR REVISION UPDATE PLEASE REFER TO HISTORY OF CHANGES.

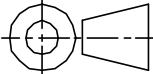
DRAFT 1	ORIGINATOR	ZAHROL		DWG. NO : PKGML00305
	ENGINEERING MANAGER			MLP QUAD PACKAGE OUTLINE
	TOOLING MANAGER	ARAVEN		5.00x7.00 MLPQ 10LD 1.00/2.54 Pitch
	TECH. SALES MANAGER	KANDA		
	DATE	2007-APR-18		PAGE: 3 of 4

10-Lead VFQFN, NR Suffix Package Outline, continued

Variation Symbol	VNJR-1									Note
D BSC	5.00									
E BSC	7.00									
b1	MIN	0.35								
	NOM	0.40								
	MAX	0.45								
b2	MIN	1.35								
	NOM	1.40								
	MAX	1.45								
D2	MIN	1.55								
	NOM	1.70								
	MAX	1.80								
E2	MIN	3.55								
	NOM	3.70								
	MAX	3.80								
L1	MIN	0.45								
	NOM	0.55								
	MAX	0.65								
L2	MIN	1.00								
	NOM	1.10								
	MAX	1.20								
N	10									
ND	2									
NE	3									
NOTES	-									
PAD DESIGN	-									

FOR REVISION UPDATE PLEASE REFER TO HISTORY OF CHANGES.

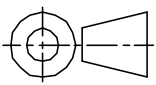
DRAFT 1	ORIGINATOR	ZAHRUL		DWG. NO : PKGML00305
	ENGINEERING MANAGER			MLP QUAD PACKAGE OUTLINE 5.00x7.00 MLPQ 10LD 1.00/2.54 Pitch
	TOOLING MANAGER	ARAVEN		
	TECH. SALES MANAGER	KANDA		
	DATE	2007-APR-18		PAGE: 4 of 4

Ordering Information

Table 9. Ordering Information

Part/Order Number	Marking	Package	Shipping Packaging	Temperature
83PN15639ANRGI	IDT83PN15639ANRGI	"Lead-Free" 10-Lead VFQFN	Tray	-40°C to 85°C
83PN15639ANRGI8	IDT83PN15639ANRGI	"Lead-Free" 10Lead VFQFN	Tape & Reel	-40°C to 85°C

Revision History]

Revision Date	Description of Change
August 16, 2016	▪ Added package dimensions to package outline.
	▪

