

THIS DOCUMENT IS THE PROPERTY OF KEYSTONE ELECTRONICS CORP. AND SHALL NOT BE REPRODUCED, DISTRIBUTED OR USED AS A BASIS FOR MANUFACTURE WITHOUT PRIOR WRITTEN PERMISSION FROM KEYSTONE ELECTRONICS CORP.

ACTUAL SIZE

P/N 8547

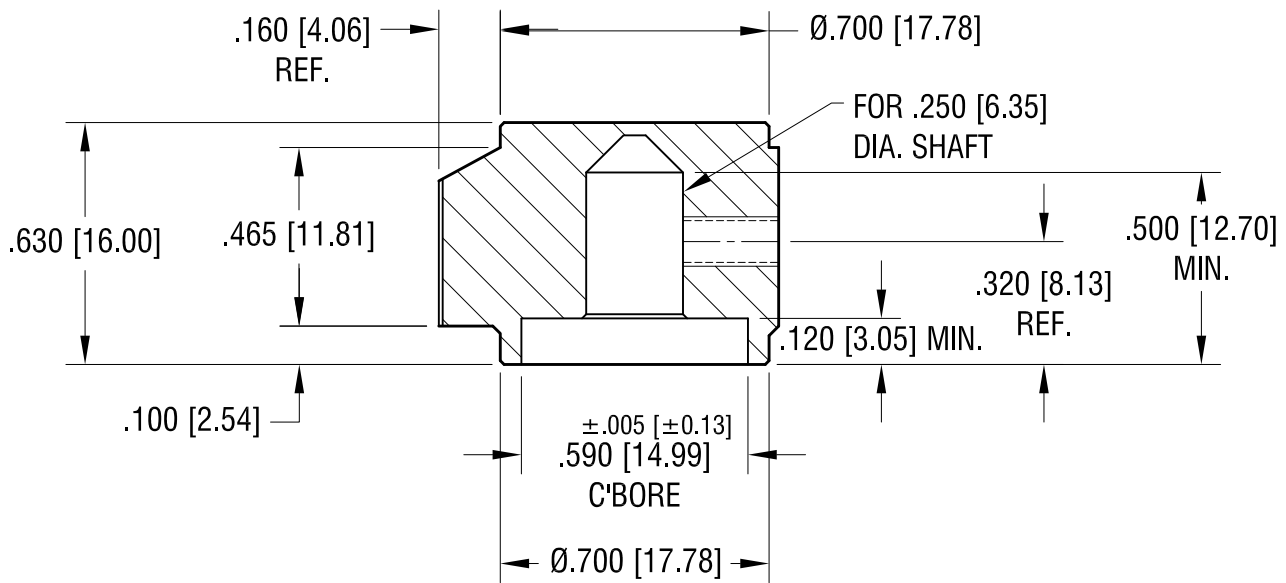
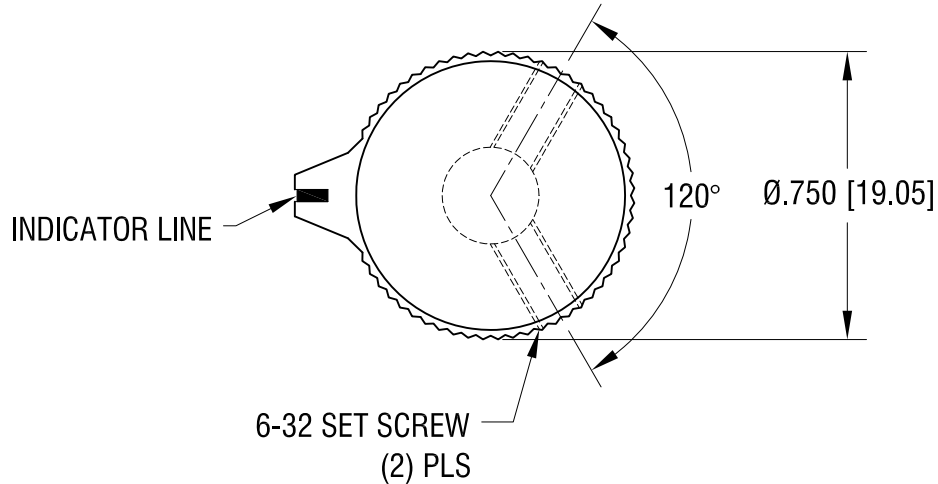
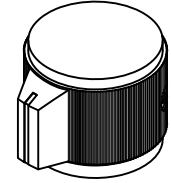

NOTES:

1. KNOB: MAT'L: ALUMINUM
FINISH: SEE CHART
2. INDICATOR PAINT LINE ON
TOP & SIDE OF KNOB,
SEE CHART FOR COLOR.

PART NUMBER	LINE COLOR (TOP & SIDE)	FINISH DESCRIPTION
8546	BLACK	CLEAR ANODIZED
8547	WHITE	BLACK ANODIZED

KEYSTONE ELECTRONICS CORP.

www.keyelco.com • NEW HYDE PARK, NY 11040 • Tel (516) 328-7500

PART NAME		KNOB	
MATERIAL		AS NOTED	
FINISH		DRN BY	DATE
AS NOTED		BOONE	1.2.07
		APP'D	SCALE
		RH	2.5X
TOLERANCES	INCH [MM]	CODE	DWG NO.
DECIMAL	± .015 [± 0.38]	C	8546 - 8547
ANGULAR	± 1°		
UNLESS OTHERWISE SPECIFIED			

DATE	DESCRIPTION	REV.
------	-------------	------