



(Image displays Absolute type)



86A

SPECIFICATIONS

- ◆ **316L SS Pressure Sensor**
- ◆ **Small Profile**
- ◆ **0.5 - 4.5V High Level Output**
- ◆ **Gage, Absolute**
- ◆ **ASIC Calibrated**

The 86A is a small profile, media compatible, piezoresistive silicon pressure sensor packaged in a 316L stainless steel housing. The 86A is designed for O-ring mounting. The sensing package utilizes silicone oil to transfer pressure from the 316L stainless steel diaphragm to the sensing element.

The 86A is designed for high performance, low pressure applications. A custom ASIC is used for temperature compensation, offset correction, and provides an amplified output of 0.5 to 4.5V.

For a similar sensor with a plastic threaded fitting, refer to the LM pressure transducer.

FEATURES

- ◆ O-Ring Mount
- ◆ -20°C to +85°C Operating Temperature Range
- ◆ ±1.0% Pressure Non Linearity
- ◆ Down to ±3.0% Total Error Band
- ◆ Solid State Reliability

APPLICATIONS

- ◆ Level Controls
- ◆ Tank Level Measurement
- ◆ OEM Equipment
- ◆ Corrosive Fluids and Gas Measurement Systems
- ◆ Sealed Systems
- ◆ Manifold Pressure Measurement
- ◆ Barometric Pressure Measurement
- ◆ Submersible Depth Monitoring

STANDARD RANGES

Range	psig	psia	Range	Barg	Bara
0 to 1	◆		0 to .07	◆	
0 to 2	◆		0 to .14	◆	
0 to 5	◆		0 to .35	◆	
0 to 15	◆	◆	0 to 1	◆	◆
0 to 30	◆	◆	0 to 2	◆	◆
0 to 50	◆	◆	0 to 5	◆	◆
0 to 100	◆	◆	0 to 7	◆	◆
0 to 150	◆	◆	0 to 10	◆	◆

*Intermediate ranges available, contact factory.

PERFORMANCE SPECIFICATIONS

Supply Voltage: 5.0Vdc

Ambient Temperature: 25°C (unless otherwise specified)

PARAMETERS	MIN	TYP	MAX	UNITS	NOTES
Full Scale Output Span		4.5		V	
Zero Pressure Output (Offset)		0.5		V	
Pressure Non Linearity	-1	±0.3	1	%Span	1
Pressure Hysteresis	-0.1		0.1	%Span	
Repeatability		±0.02		%Span	
Temperature Error – Span (0°C to 40°C)		1, 2psi and .07bar: ±2.0 ≥5psi or ≥.35bar: ±1.5		%Span	2
Temperature Error – Zero (0°C to 40°C)		1, 2psi and .07bar: ±2.0 ≥5psi or ≥.35bar: ±1.5		%Span	2
Accuracy (combined linearity, hysteresis & repeatability)		0.25		%Span	1
Total Error Band (includes calibration errors above & temperature effects over the compensated range)		1, 2psi and .07bar: ±7 5psi and .35bar: ±5 >5psi or .35bar: ±3		%Span	
Supply Voltage	4.75	5.00	5.25	V	3
Insulation Resistance (50Vdc)	50			MΩ	4
Pressure Overload			3X	Rated	
Compensated Temperature	0		+40	°C	
Operating Temperature	-20		+85	°C	
Media – Pressure Port	Liquids and Gases compatible with 316L Stainless Steel				

Notes

1. Best fit straight line.
2. Over the compensated temperature range with respect to 25°C.
3. Guarantees output/input ratiometricity.
4. Between case and sensing element.
5. The maximum pressure that can be applied to a transducer without rupture of either the sensing element or transducer.

DIMENSIONS

DIMENSIONS ARE IN INCHES [mm]

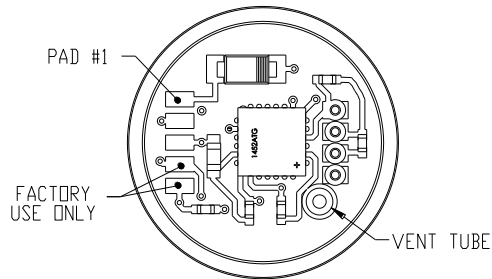
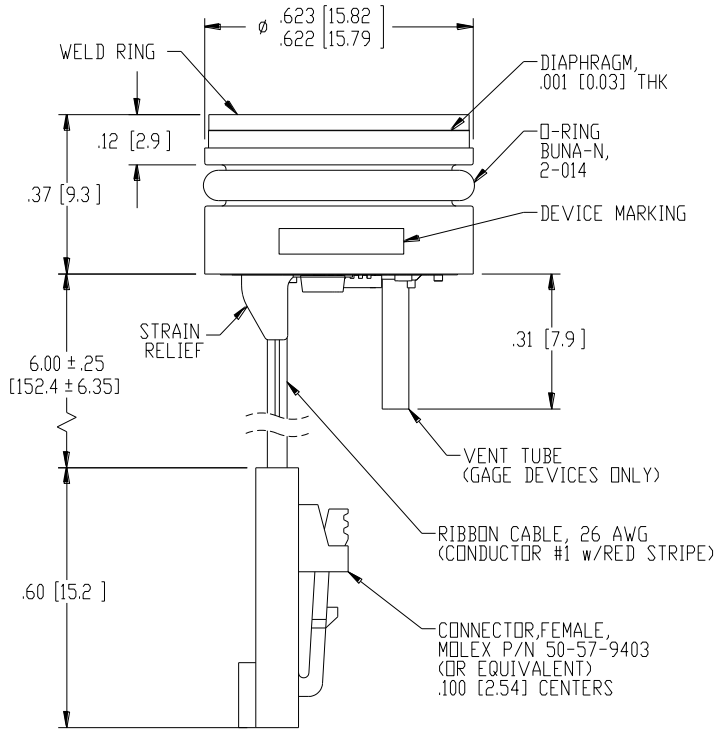

VIEW SHOWN w/o CABLE AND CONNECTOR FOR CLARITY

PAD/WIRE NO	FUNCTION
1	+Vin
2	GND
3	+Vout

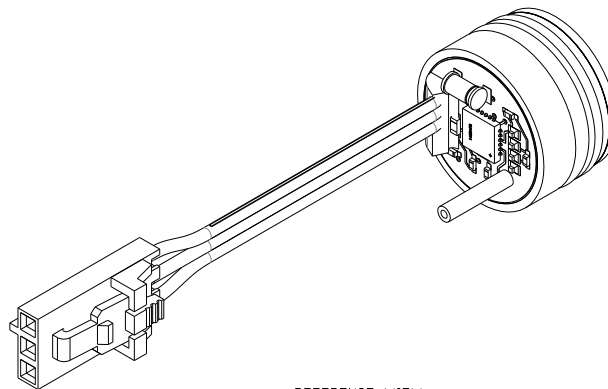

REFERENCE VIEW (GAGE DEVICE SHOWN)

