

General Description

The 885137 is a high-performance Bulk Acoustic Wave (BAW) filter module designed to meet the strict LTE requirements for use in LTE from 699–2400 MHz and 2496–2690 MHz and WLAN requirements.

885137 is specifically designed to meet the high performance expectations of insertion loss and rejection for LTE and WLAN systems under all operating conditions. 885137 allows diplexing the Cellular path and a filtered WiFi path to one antenna port.

The 885137 uses common module packaging techniques to achieve the industry standard 1.7 x 1.3 x 0.46 mm footprint.

Functional Block Diagram

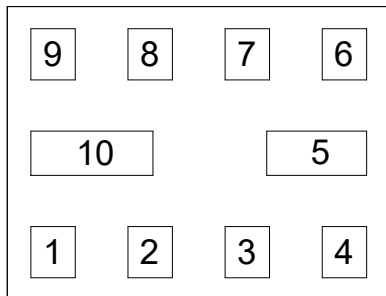

Top View

Pin Configuration - Single Ended

Pin No.	Label
1	RF3
4	RF2
6	SMD# 1 to RF2
7	SMD# 2 to RF1, SMD# 4 to Ground
9	RF1 (ANT)
2,3,5,8,10	Ground

*Note: See Evaluation Board section page 11 for details on optimal grounding

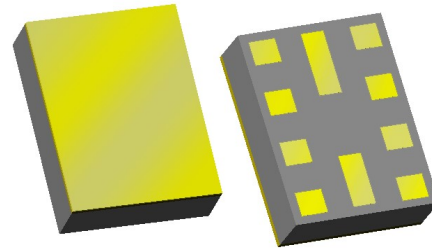

CSP-1713 package: 1.70 x 1.30 x 0.46 mm

Product Features

- Diplexer is formed with WiFi Bandpass and Band stop filters.
- Highly selective BAW filters achieving low insertion loss and high attenuation over full bandwidth and operating conditions
- Rejection in WLAN band of 10 dB minimum
- Single antenna port, diplexing
- Performance -40 to +95 °C
- RoHS compliant, Pb-free module package



Applications

- Usable Bandwidth of 79 MHz (CH1 – 13)
- For WLAN coexistence to B7, B38, B40 and B41 LTE applications
- LTE gateways, data cards and routers
- WiFi antenna extractor circuits.
- High-power WLAN Access Points and Small Cells
- 2.4 GHz ISM applications
- Wi-Fi Set Top Box, Gateways and Routers-

Ordering Information

Part No.	Description
885137	15,000 units/reel (standard)
885137-EVB	Evaluation board

Absolute Maximum Ratings

Parameter	Rating
Storage Temperature ⁽¹⁾	-55 to +150 °C
Operating Temperature ⁽²⁾	-20 to +85 °C
RF Input Power	
RF2 (Cell Port)	+25 dBm
RF3 (WiFi Port)	+20 dBm

Notes:

1. Operation of this device outside the parameter ranges given may cause permanent damage.
2. Specifications are not guaranteed over all operating conditions.
3. TD-SCDMA, LTE continuous; simultaneously TX power presence at RF2 and RF3.

Electrical Specifications ⁽¹⁾

Operating Temp = -40 to +95°C, Characteristic Impedance [Z0] = 50 Ω. (Unless otherwise noted)

RF1 to RF2 (Ant- Cell)(S12)

Parameter ⁽³⁾	Conditions	Min	Typ ⁽²⁾	Max	Units
Insertion Loss	699 – 960 MHz	-	1.3	2.3	dB
	1574 – 1615 MHz		0.8	0.9	
	1710 – 2170 MHz		1.0	1.3	
	2300 – 2370 MHz		1.9	3.2	
	2370 – 2377.5 MHz		2.5	4.7	
	2496 – 2510 MHz		2.0	3.7	
	2510 – 2570 MHz		1.0	1.5	
	2570 – 2690 MHz		1.0	1.4	
Amplitude Variation (within any 20 MHz)	2300 – 2370 MHz	-	0.4	1.3	dB p-p
	2496 – 2510 MHz		1.1	2.8	
	2510 – 2570 MHz		0.3	0.7	
VSWR (In/Out)	2300 – 2370 MHz	-	1.4	2.0	-
	2496 – 2510 MHz		1.9	3.1	
	2510 – 2570 MHz		1.4	2.4	
	2570 – 2690 MHz		1.4	2.0	

Notes:

1. All specifications are based on the Qorvo schematic for the reference design shown on page 11.
2. In production, devices will be tested at room temperature to a guardbanded specification to ensure electrical compliance over temperature.
3. Electrical margin has been built into design to account the variations due to temperature drift and manufacturing tolerances.

Electrical Specifications ⁽¹⁾

Operating Temp = -40 to +95°C, Characteristic Impedance [ZO] = 50 Ω. (Unless otherwise noted)

RF1 to RF2 (Ant- Cell) (S12)

Parameter ⁽³⁾	Conditions	Min	Typ ⁽²⁾	Max	Units
Attenuation ⁽⁶⁾	2402 – 2478.64 MHz ⁽⁴⁾	15	18		dB
	2478.64 – 2482 MHz ⁽⁴⁾	13	18		
	2402.5 – 2421.5 MHz (ISM Ch 1) ⁽⁵⁾	20	25		
	2407.5 – 2426.5 MHz (ISM Ch 2) ⁽⁵⁾	17	22		
	2412.5 – 2431.5 MHz (ISM Ch 3) ⁽⁵⁾	16	20		
	2417.5 – 2436.5 MHz (ISM Ch 4) ⁽⁵⁾	16	19		
	2422.5 – 2441.5 MHz (ISM Ch 5) ⁽⁵⁾	16	19		
	2427.5 – 2446.5 MHz (ISM Ch 6) ⁽⁵⁾	16	19	-	
	2432.5 – 2451.5 MHz (ISM Ch 7) ⁽⁵⁾	16	20		
	2437.5 – 2456.5 MHz (ISM Ch 8) ⁽⁵⁾	17	21		
	2442.5 – 2461.5 MHz (ISM Ch 9) ⁽⁵⁾	17	23		
	2447.5 – 2466.5 MHz (ISM Ch 10) ⁽⁵⁾	21	26		
	2452.5 – 2471.5 MHz (ISM Ch 11) ⁽⁵⁾	24	27		
	2457.5 – 2476.5 MHz (ISM Ch 12) ⁽⁵⁾	19	26		
2462.5 – 2481.5 MHz (ISM Ch 13) ⁽⁵⁾	17	22			

RF2 to RF3 Isolation (Cell - WiFi) (S23)

Attenuation ⁽⁶⁾	2300 – 2370 MHz	41	49		dB
	2402 – 2482 MHz ⁽⁴⁾	17	19		
	ISM CH 1 – 13 ⁽⁵⁾	17	20		
	2570 – 2690 MHz ⁽⁴⁾	42	45		
	2496 – 2500 MHz	13	28	-	
	2500 – 2510 MHz	25	44		
	2510 – 2570 MHz	49	53		
	2370 – 2400 MHz	12	16		

Notes:

1. All specifications are based on the Qorvo schematic for the reference design shown on page 11.
2. In production, devices will be tested at room temperature to a guardbanded specification to ensure electrical compliance over temperature.
3. Electrical margin has been built into design to account the variations due to temperature drift and manufacturing tolerances.
4. Data is the integrated value of the linear s-parameter over a 1 MHz range in the indicated band.
5. Data is the integrated value of the linear s-parameter over 19MHz range in the indicated band.
6. Reference to zero dB.

Electrical Specifications ⁽¹⁾

Operating Temp = -40 to +95°C, Characteristic Impedance [ZO] = 50 Ω. (Unless otherwise noted)

RF1 to RF3 (Ant- WiFi) (S13)

Parameter ⁽³⁾	Conditions	Min	Typ ⁽²⁾	Max	Units
Insertion Loss	2402 – 2480 MHz	-	2.6	4.2	dB
	2402 – 2475.81 MHz ⁽⁴⁾		2.4	3.4	
	2475.81 – 2480 MHz ⁽⁴⁾		2.4	4.3	
	ISM CH 1 – 12 ⁽⁵⁾		1.8	2.3	
	ISM CH 13 ⁽⁵⁾		1.8	2.7	
Amplitude Variation	2402 – 2480 MHz	-	1.5	3.1	dB p-p
	2402 – 2480 MHz (within any 20 MHz)		1.3	2.7	
Attenuation ⁽⁶⁾	10 – 1549 MHz	44	45	-	dB
	1549 – 1615 MHz	44	45		
	1710 – 1990 MHz	41	42		
	2110 – 2170 MHz	40	42		
	2300 – 2370 MHz	46	48		
	2496 – 2500 MHz	12	25		
	2500 – 2570 MHz	22	39		
	2570 – 2690 MHz	42	44		
VSWR (In/Out)	2402 – 2480 MHz	-	1.7	2.6	-

Notes:

1. All specifications are based on the Qorvo schematic for the reference design shown on page 11.
2. In production, devices will be tested at room temperature to a guardbanded specification to ensure electrical compliance over temperature.
3. Electrical margin has been built into design to account the variations due to temperature drift and manufacturing tolerances
4. Data is the integrated value of the linear s-parameter over a 1 MHz range in the indicated band.
5. Data is the integrated value of the linear s-parameter over 19MHz range in the indicated band.
6. Reference to zero dB.

Electrical Specifications ⁽¹⁾

Operating Temp = -30 to +85°C, Characteristic Impedance [Z0] = 50 Ω. (Unless otherwise noted)

RF1 to RF2 (Ant- Cell) (S12)

Parameter ⁽³⁾	Conditions	Min	Typ ⁽²⁾	Max	Units
Insertion Loss	699 – 960 MHz		1.3	2.3	dB
	1574 – 1615 MHz		0.8	0.9	
	1710 – 2170 MHz		1.0	1.2	
	2300 – 2370 MHz		1.9	3.1	
	2370 – 2377.5 MHz	-	2.5	4.6	
	2496 – 2510 MHz		2.0	3.6	
	2510 – 2570 MHz		1.0	1.5	
	2570 – 2690 MHz		1.0	1.4	
Amplitude Variation (within any 20 MHz)	2300 – 2370 MHz		0.4	1.3	dB p-p
	2496 – 2510 MHz		1.1	2.7	
	2510 – 2570 MHz	-	0.3	0.7	
VSWR (In/Out)	2300 – 2370 MHz		1.4	2.0	-
	2496 – 2510 MHz		1.9	3.0	
	2510 – 2570 MHz	-	1.4	2.3	
	2570 – 2690 MHz		1.4	2.0	

Notes:

1. All specifications are based on the Qorvo schematic for the reference design shown on page 11.
2. In production, devices will be tested at room temperature to a guardbanded specification to ensure electrical compliance over temperature.
3. Electrical margin has been built into design to account the variations due to temperature drift and manufacturing tolerances.

Electrical Specifications ⁽¹⁾

Operating Temp = -30 to +85°C, Characteristic Impedance [ZO] = 50 Ω. (Unless otherwise noted)

RF1 to RF2 (Ant- Cell) (S12)

Parameter ⁽³⁾	Conditions	Min	Typ ⁽²⁾	Max	Units
Attenuation ⁽⁶⁾	2402 – 2478.64 MHz ⁽⁴⁾	15	18		dB
	2478.64 – 2482 MHz ⁽⁴⁾	14	18		
	2402.5 – 2421.5 MHz (ISM Ch 1) ⁽⁵⁾	20	25		
	2407.5 – 2426.5 MHz (ISM Ch 2) ⁽⁵⁾	17	22		
	2412.5 – 2431.5 MHz (ISM Ch 3) ⁽⁵⁾	16	20		
	2417.5 – 2436.5 MHz (ISM Ch 4) ⁽⁵⁾	16	19		
	2422.5 – 2441.5 MHz (ISM Ch 5) ⁽⁵⁾	16	19		
	2427.5 – 2446.5 MHz (ISM Ch 6) ⁽⁵⁾	16	19	-	
	2432.5 – 2451.5 MHz (ISM Ch 7) ⁽⁵⁾	16	20		
	2437.5 – 2456.5 MHz (ISM Ch 8) ⁽⁵⁾	17	21		
	2442.5 – 2461.5 MHz (ISM Ch 9) ⁽⁵⁾	17	23		
	2447.5 – 2466.5 MHz (ISM Ch 10) ⁽⁵⁾	21	26		
	2452.5 – 2471.5 MHz (ISM Ch 11) ⁽⁵⁾	24	27		
2457.5 – 2476.5 MHz (ISM Ch 12) ⁽⁵⁾	19	26			
2462.5 – 2481.5 MHz (ISM Ch 13) ⁽⁵⁾	17	22			

RF2 to RF3 Isolation (Cell - WiFi) (S23)

Attenuation ⁽⁶⁾	2300 – 2370 MHz	41	49		dB
	2402 – 2482 MHz ⁽⁴⁾	17	19		
	ISM CH 1 – 13 ⁽⁵⁾	17	20		
	2570 – 2690 MHz ⁽⁴⁾	42	45		
	2496 – 2500 MHz	13	28	-	
	2500 – 2510 MHz	26	44		
	2510 – 2570 MHz	49	53		
	2370 – 2400 MHz	12	16		

Notes:

1. All specifications are based on the Qorvo schematic for the reference design shown on page 11.
2. In production, devices will be tested at room temperature to a guardbanded specification to ensure electrical compliance over temperature.
3. Electrical margin has been built into design to account the variations due to temperature drift and manufacturing tolerances.
4. Data is the integrated value of the linear s-parameter over a 1 MHz range in the indicated band.
5. Data is the integrated value of the linear s-parameter over 19 MHz range in the indicated band.
6. Reference to zero dB.

Electrical Specifications ⁽¹⁾

Operating Temp = -30 to +85°C, Characteristic Impedance [ZO] = 50 Ω. (Unless otherwise noted)

RF1 to RF3 (Ant- WiFi) (S13)

Parameter ⁽³⁾	Conditions	Min	Typ ⁽²⁾	Max	Units
Insertion Loss	2402 – 2480 MHz	-	2.6	4.0	dB
	2402 – 2475.81 MHz ⁽⁴⁾		2.4	3.4	
	2475.81 – 2480 MHz ⁽⁴⁾		2.4	4.1	
	ISM CH 1 – 12 ⁽⁵⁾		1.8	2.2	
	ISM CH 13 ⁽⁵⁾		1.8	2.6	
Amplitude Variation	2402 – 2480 MHz	-	1.5	2.9	dB p-p
	2402 – 2480 MHz (within any 20 MHz)		1.3	2.6	
Attenuation ⁽⁶⁾	10 – 1549 MHz	44	45	-	-
	1549 – 1615 MHz	44	45		
	1710 – 1990 MHz	41	42		
	2110 – 2170 MHz	40	42		
	2300 – 2370 MHz	46	48		
	2496 – 2500 MHz	12	25		
	2500 – 2570 MHz	23	39		
	2570 – 2690 MHz	42	44		
VSWR (In/Out)	2402 – 2480 MHz	-	1.7	2.5	-

Notes:

1. All specifications are based on the Qorvo schematic for the reference design shown on page 11.
2. In production, devices will be tested at room temperature to a guardbanded specification to ensure electrical compliance over temperature.
3. Electrical margin has been built into design to account the variations due to temperature drift and manufacturing tolerances.
4. Data is the integrated value of the linear s-parameter over a 1 MHz range in the indicated band.
5. Data is the integrated value of the linear s-parameter over 19 MHz range in the indicated band.
6. Reference to zero dB.

Electrical Specifications ⁽¹⁾

Operating Temp = 0 to +70 °C, Characteristic Impedance [Z0] = 50 Ω. (Unless otherwise noted)

RF1 to RF2 (Ant- Cell) (S12)

Parameter ⁽³⁾	Conditions	Min	Typ ⁽²⁾	Max	Units
Insertion Loss	699 – 960 MHz	-	1.3	2.3	dB
	1574 – 1615 MHz		0.8	0.9	
	1710 – 2170 MHz		1.0	1.2	
	2300 – 2370 MHz		1.9	3.0	
	2370 – 2377.5 MHz		2.5	4.4	
	2496 – 2510 MHz		2.0	3.3	
	2510 – 2570 MHz		1.0	1.5	
Amplitude Variation (within any 20 MHz)	2300 – 2370 MHz	-	0.4	1.2	dB p-p
	2496 – 2510 MHz		1.1	2.3	
	2510 – 2570 MHz		0.3	0.6	
VSWR (In/Out)	2300 – 2370 MHz	-	1.4	2.0	-
	2496 – 2510 MHz		1.9	2.9	
	2510 – 2570 MHz		1.4	2.3	
	2570 – 2690 MHz		1.4	2.0	

Notes:

1. All specifications are based on the Qorvo schematic for the reference design shown on page 11.
2. In production, devices will be tested at room temperature to a guardbanded specification to ensure electrical compliance over temperature.
3. Electrical margin has been built into design to account the variations due to temperature drift and manufacturing tolerances.

Electrical Specifications ⁽¹⁾

Operating Temp = 0 to +70 °C, Characteristic Impedance [ZO] = 50 Ω. (Unless otherwise noted)

RF1 to RF2 (Ant- Cell) (S12)

Parameter ⁽³⁾	Conditions	Min	Typ ⁽²⁾	Max	Units
Attenuation ⁽⁶⁾	2402 – 2478.64 MHz ⁽⁴⁾	15	18		dB
	2478.64 – 2482 MHz ⁽⁴⁾	14	18		
	2402.5 – 2421.5 MHz (ISM Ch 1) ⁽⁵⁾	21	25		
	2407.5 – 2426.5 MHz (ISM Ch 2) ⁽⁵⁾	17	22		
	2412.5 – 2431.5 MHz (ISM Ch 3) ⁽⁵⁾	16	20		
	2417.5 – 2436.5 MHz (ISM Ch 4) ⁽⁵⁾	16	19		
	2422.5 – 2441.5 MHz (ISM Ch 5) ⁽⁵⁾	16	19		
	2427.5 – 2446.5 MHz (ISM Ch 6) ⁽⁵⁾	16	19	-	
	2432.5 – 2451.5 MHz (ISM Ch 7) ⁽⁵⁾	16	20		
	2437.5 – 2456.5 MHz (ISM Ch 8) ⁽⁵⁾	17	21		
	2442.5 – 2461.5 MHz (ISM Ch 9) ⁽⁵⁾	18	23		
	2447.5 – 2466.5 MHz (ISM Ch 10) ⁽⁵⁾	22	26		
	2452.5 – 2471.5 MHz (ISM Ch 11) ⁽⁵⁾	24	27		
2457.5 – 2476.5 MHz (ISM Ch 12) ⁽⁵⁾	20	26			
2462.5 – 2481.5 MHz (ISM Ch 13) ⁽⁵⁾	17	22			

RF2 to RF3 Isolation (Cell - WiFi)(S23)

Attenuation ⁽⁶⁾	2300 – 2370 MHz	41	49		dB
	2402 – 2482 MHz ⁽⁴⁾	17	19		
	ISM CH 1 – 13 ⁽⁵⁾	17	20		
	2570 – 2690 MHz ⁽⁴⁾	42	45		
	2496 – 2500 MHz	14	28		
	2500 – 2510 MHz	27	44		
	2510 – 2570 MHz	49	53		
	2370 – 2400 MHz	12	16		

Notes:

1. All specifications are based on the Qorvo schematic for the reference design shown on page 11.
2. In production, devices will be tested at room temperature to a guardbanded specification to ensure electrical compliance over temperature.
3. Electrical margin has been built into design to account the variations due to temperature drift and manufacturing tolerances.
4. Data is the integrated value of the linear s-parameter over a 1 MHz range in the indicated band.
5. Data is the integrated value of the linear s-parameter over 19 MHz range in the indicated band.
6. Reference to zero dB.

Electrical Specifications ⁽¹⁾

Operating Temp = 0 to +70 °C, Characteristic Impedance [Z0] = 50 Ω. (Unless otherwise noted)

RF1 to RF3 (Ant- WiFi) (S13)

Parameter ⁽³⁾	Conditions	Min	Typ ⁽²⁾	Max	Units
Insertion Loss	2402 – 2480 MHz	-	2.6	3.8	dB
	2402 – 2475.81 MHz ⁽⁴⁾		2.4	3.3	
	2475.81 – 2480 MHz ⁽⁴⁾		2.4	3.8	
	ISM CH 1 – 12 ⁽⁵⁾		1.8	2.2	
	ISM CH 13 ⁽⁵⁾		1.8	2.5	
Amplitude Variation	2402 – 2480 MHz	-	1.5	2.7	dB p-p
	2402 – 2480 MHz (within any 20 MHz)		1.3	2.4	
Attenuation ⁽⁶⁾	10 – 1549 MHz	44	45	-	-
	1549 – 1615 MHz	44	45		
	1710 – 1990 MHz	41	42		
	2110 – 2170 MHz	41	42		
	2300 – 2370 MHz	46	48		
	2496 – 2500 MHz	12	25		
	2500 – 2570 MHz	26	39		
	2570 – 2690 MHz	42	44		
VSWR (In/Out)	2402 – 2480 MHz	1	1.7	2.4	-

Notes:

1. All specifications are based on the Qorvo schematic for the reference design shown on page 11.
2. In production, devices will be tested at room temperature to a guardbanded specification to ensure electrical compliance over temperature.
3. Electrical margin has been built into design to account the variations due to temperature drift and manufacturing tolerances.
4. Data is the integrated value of the linear s-parameter over a 1 MHz range in the indicated band.
5. Data is the integrated value of the linear s-parameter over 19 MHz range in the indicated band.
6. Reference to zero dB.

Evaluation Board

Schematic

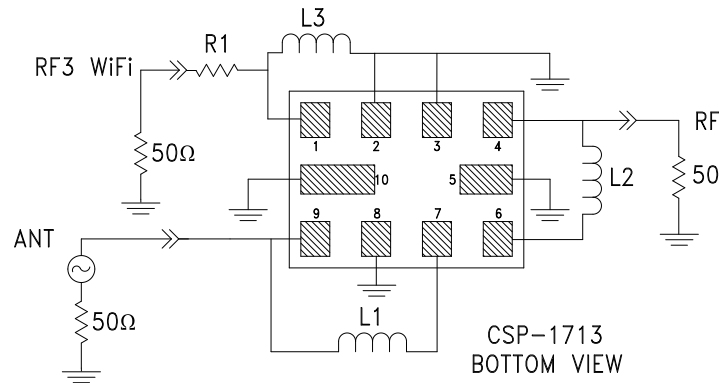
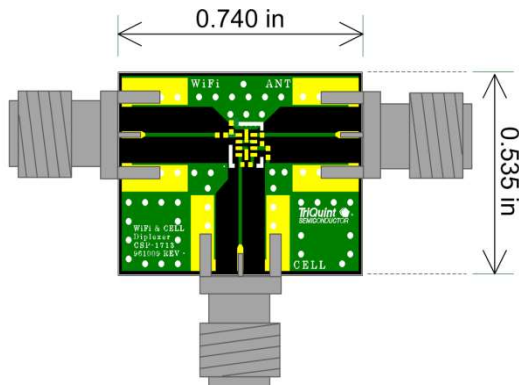

Notes:

- This is the optimum impedance in order to achieve the performance shown.
PCB: 0.75 x 0.75 x 0.063; Construction: 1 OZ Cu Top, Middle and Bottom Layers; Material in between middle and top layer: TLY-5A (.0075); Material in between mid-bottom layers: FR4. (Dimensions are in inches)

Bill of Material

Reference Des.	Value	Description	Manuf.	Part Number
U1	n/a	Diplexer	TriQuint	885137
L1	3.2 nH	3.2 nH ± 0.1 nH; 0201 SMD	Murata	LQP03TN3N2B02
L2	3.6 nH	3.6 nH ± 0.1 nH; 0201 SMD	Murata	LQP03TN3N6B02
L3	6.2 nH	6.2 nH ± 3 %; 0201 SMD	Murata	LQP03TN6N2H02
R1	0 Ω	0.0 Ohm 1/20 W jumper; 0201	Panasonic	ERJ1GN0R00C
SMA	N/A	SMA connector	Radiall	9602-1111-018
PCB	n/a	Printed Circuit Board	TriQuint	961009

PCB Mounting Pattern

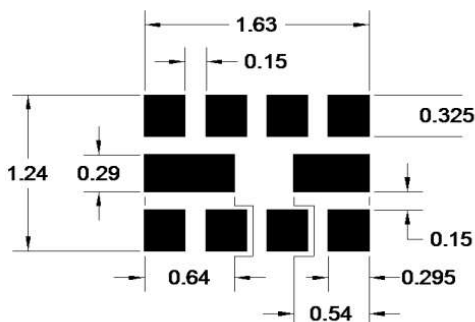

Notes:

- All dimensions are in millimeters. Angles are in degrees.
- This drawing specifies the mounting pattern used on the TriQuint evaluation board for this product. Some modification may be necessary to suit end user assembly materials and processes

Performance Plots – RF1 to RF3 (ANT-WiFi) (S13)

Test conditions unless otherwise noted: Temp= +25 °C

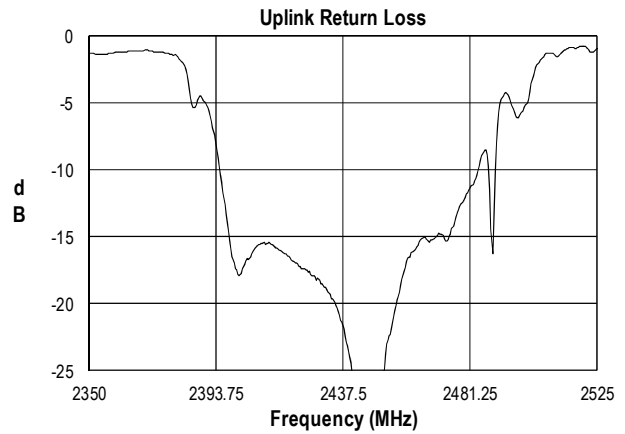
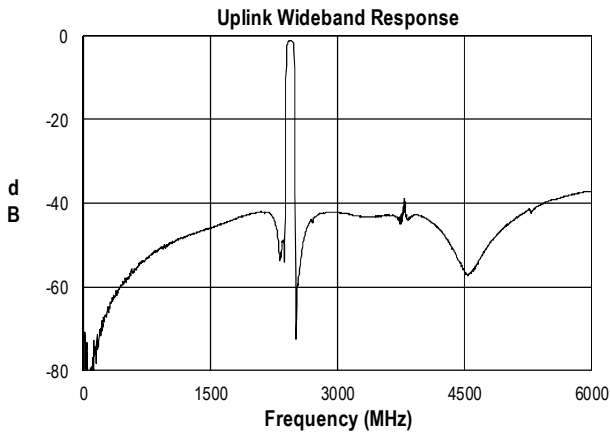
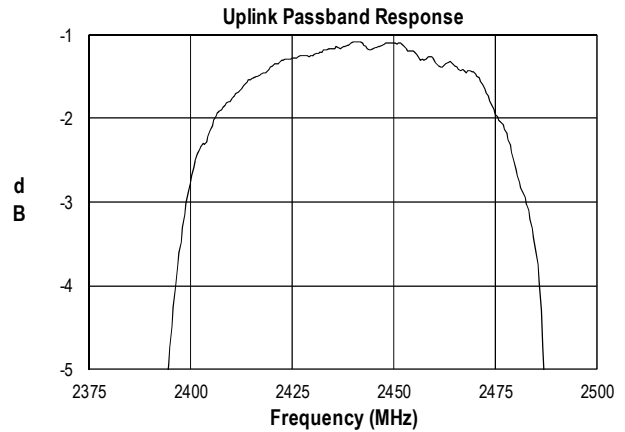
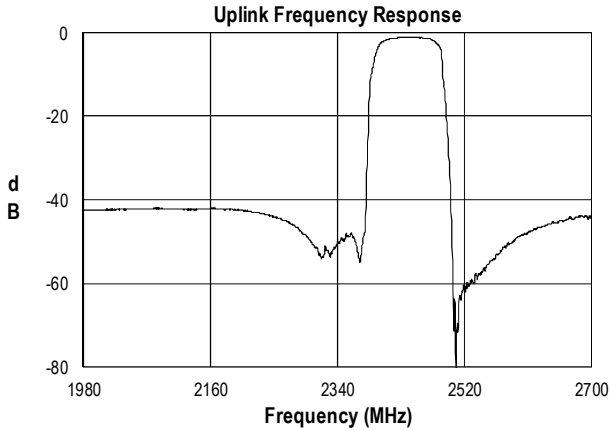

Uplink Path - Antenna Port Impedance

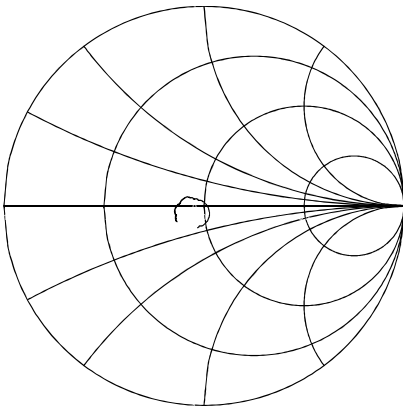

Uplink Port Impedance

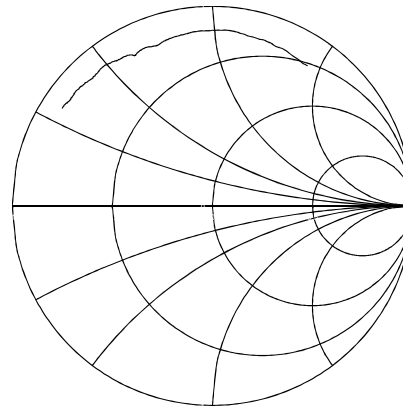

Performance Plots- RF1 to RF2 (ANT- Cell) (S12)

Test conditions unless otherwise noted: Temp= +25 °C

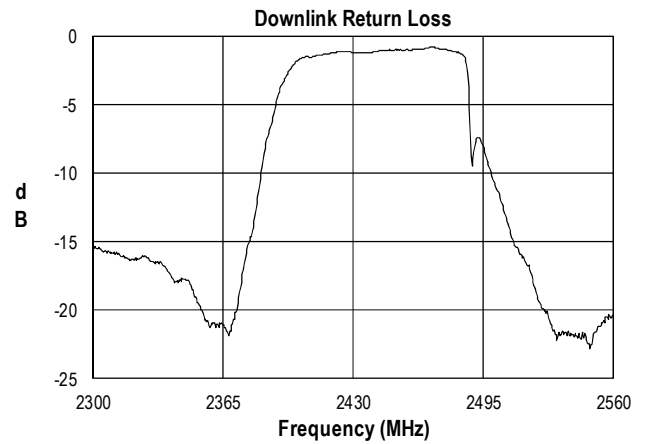
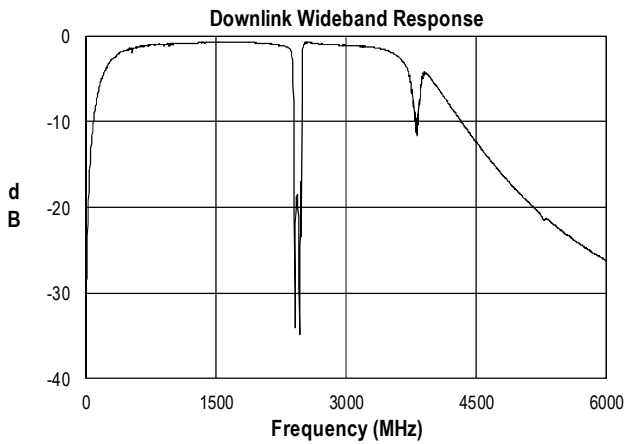
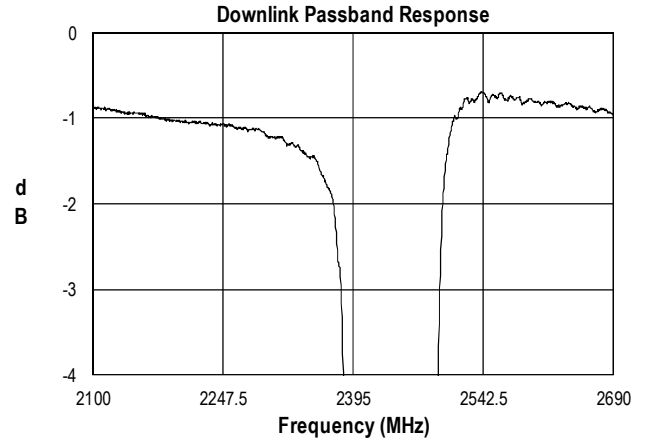
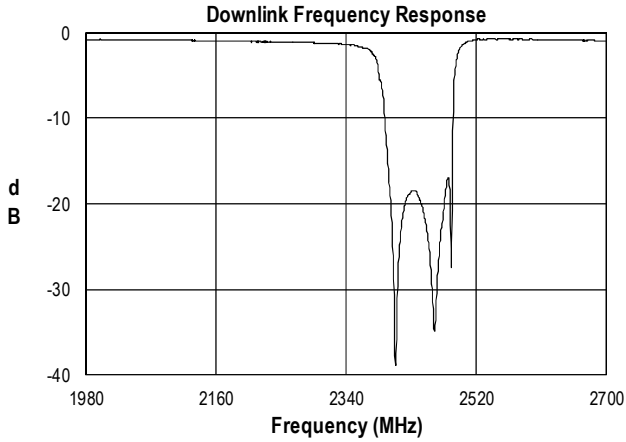

Downlink Path - Antenna Port Impedance

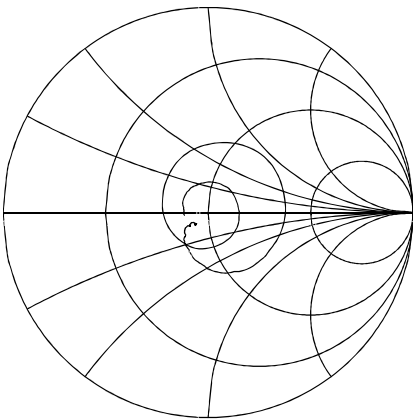

Downlink Port Impedance

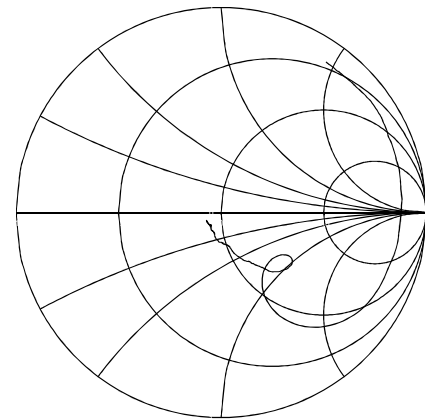

Performance Plots - RF2 to RF3 (Cell - WiFi) (S23)

Test conditions unless otherwise noted: Temp= +25 °C

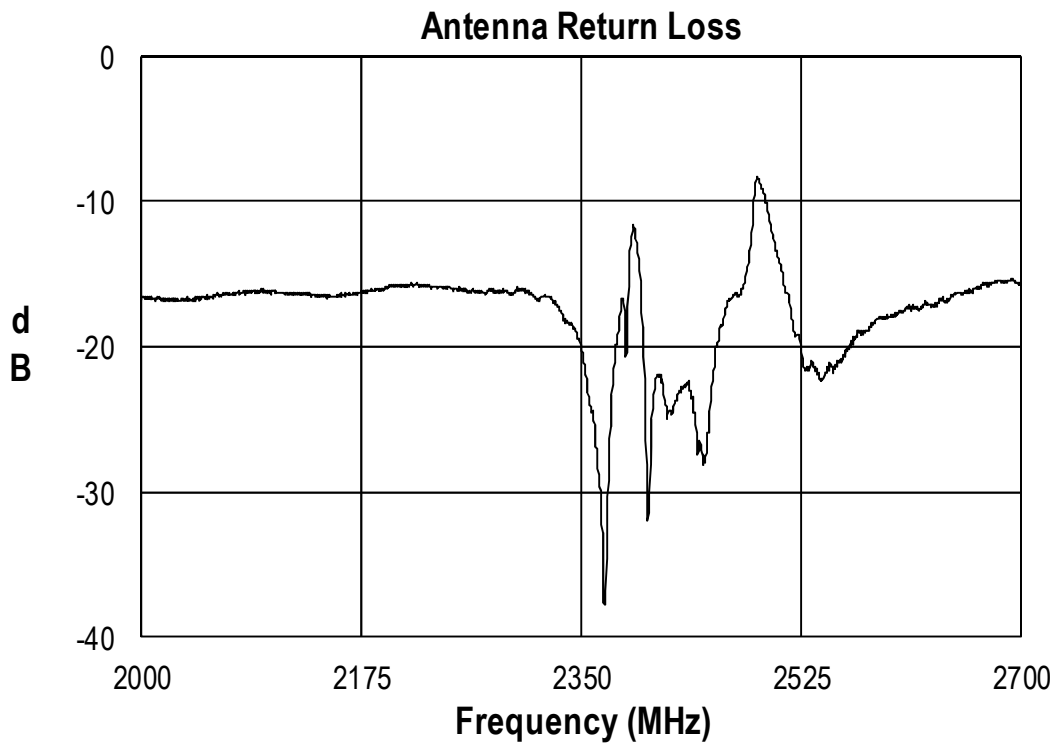
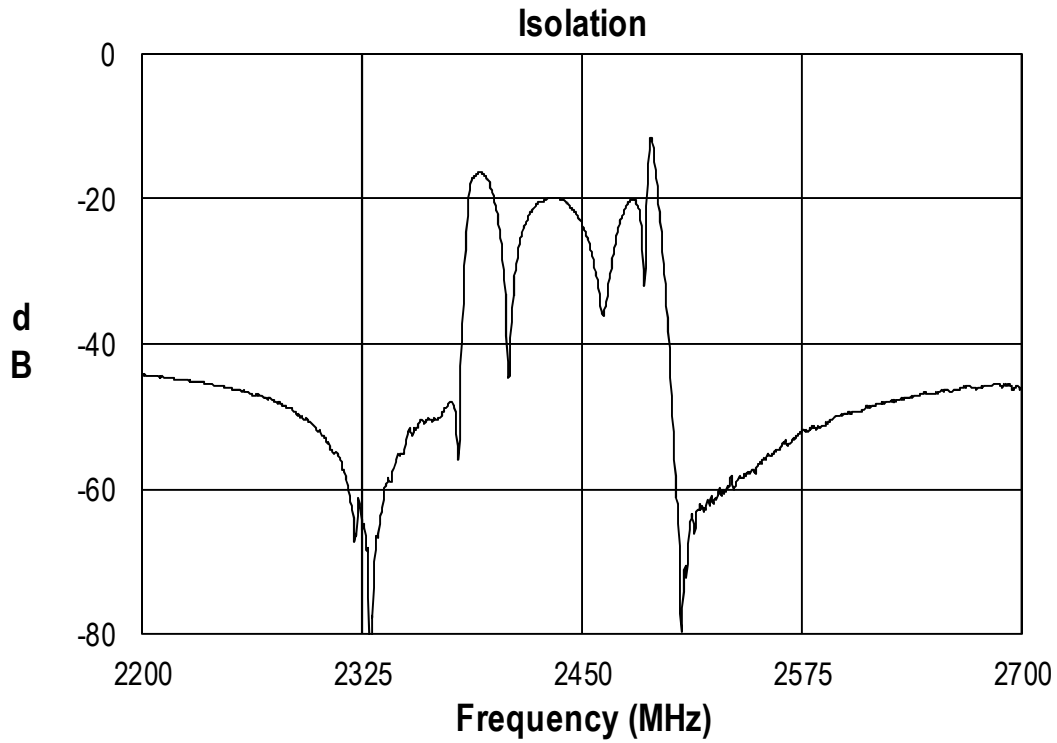

Package Information, Marking and Dimensions

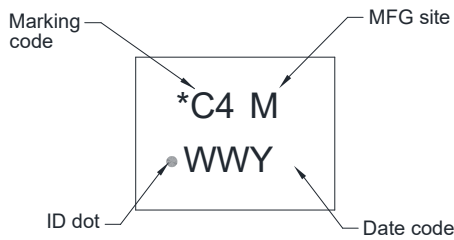

Package Style: CSP-1713
Dimensions: 1.7 x 1.3 x 0.50 mm

Package for Surface Mount Technology
Terminations: Au plating 0.5 - 1.0 μm, over a 2-6 μm Ni Plating
Approximate weight 3.96 mg

All dimensions shown are nominal in millimeters.
Unless otherwise specified all tolerances are ±0.05mm except length and width that are specified as ±0.1mm

The Marking Code is correlated with the Part Number
M=Manufacturing Site Code (Blank for Apopka, C for Costa Rica)
The Date Code consists of:
WW = 2 digit week
Y=The last digit of the year

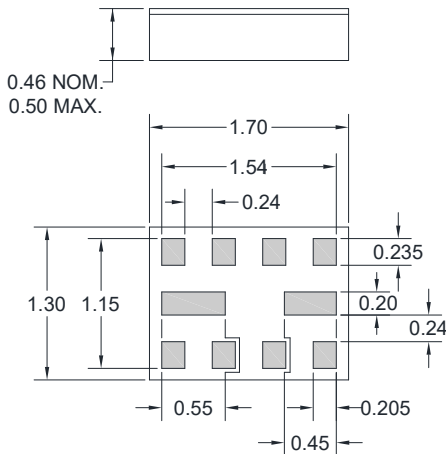

- Notes:
1. All dimensions shown are typical in millimeters
 2. An asterisk (*) in front of the marking code indicates prototype.

Tape and Reel information

Standard T/R size = 15,000 units/reel. All dimensions are in millimeters

