

Description

The 8SLVD1204 is a high-performance differential LVDS fanout buffer. The device is designed for the fanout of high-frequency, very low additive phase-noise clock and data signals. The 8SLVD1204 is characterized to operate from a 2.5V power supply. Guaranteed output-to-output and part-to-part skew characteristics make the 8SLVD1204 ideal for those clock distribution applications demanding well-defined performance and repeatability.

Two selectable differential inputs and four low skew outputs are available. The integrated bias voltage reference enables easy interfacing of single-ended signals to the device inputs. The device is optimized for low power consumption and low additive phase noise.

Features

- Four low skew, low additive jitter LVDS output pairs
- Two selectable differential clock input pairs
- Differential PCLK, nPCLK pairs can accept the following differential input levels: LVDS, LVPECL
- Maximum input clock frequency: 2GHz
- LVCMOS/LVTTL interface levels for the control input select pin
- Output skew: 20ps (maximum)
- Propagation delay: 300ps (maximum)
- Low additive phase jitter, RMS; $f_{REF} = 156.25\text{MHz}$, $V_{PP} = 1\text{V}$, 10kHz - 20MHz: 95fs (maximum)
- Full 2.5V supply voltage
- Lead-free (RoHS 6), 16-Lead VFQFPN packaging
- Supports case temperature $\leq 105^\circ\text{C}$ operations
- -40°C to 85°C ambient operating temperature

Block Diagram

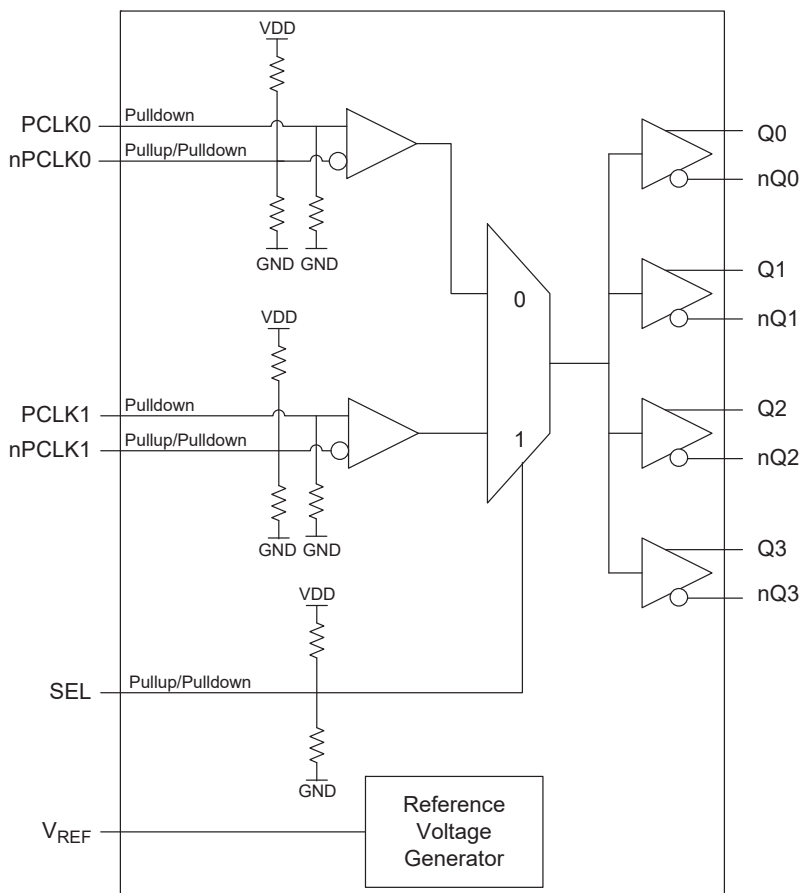

Pin Assignment

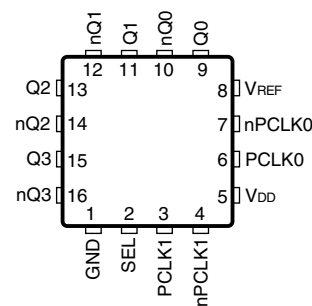

8SLVD1204
16 lead VFQFPN
3.0mm x 3.0mm x 0.9mm package body
1.7mm x 1.7mm ePad
NL Package
Top View

Pin Description and Pin Characteristic Tables

Table 1. Pin Descriptions

Number	Name	Type		Description
1	GND	Power		Power supply ground.
2	SEL	Input	Pullup/ Pulldown	Reference select control pin. See Table 3 for function. LVCMOS/LVTTL interface levels.
3	PCLK1	Input	Pulldown	Non-inverting differential clock/data input.
4	nPCLK1	Input	Pullup/ Pulldown	Inverting differential clock/data input. $V_{DD}/2$ default when left floating.
5	V_{DD}	Power		Power supply pin.
6	PCLK0	Input	Pulldown	Non-inverting differential clock/data input.
7	nPCLK0	Input	Pullup/ Pulldown	Inverting differential clock/data input. $V_{DD}/2$ default when left floating.
8	V_{REF}	Output		Bias voltage reference for the PCLK, nPCLK inputs.
9, 10	Q0, nQ0	Output		Differential output pair 0. LVDS interface levels.
11, 12	Q1, nQ1	Output		Differential output pair 1. LVDS interface levels.
13, 14	Q2, nQ2	Output		Differential output pair 2. LVDS interface levels.
15, 16	Q3, nQ3	Output		Differential output pair 3. LVDS interface levels.

NOTE: *Pulldown* and *Pullup* refer to internal input resistors. See Table 2, *Pin Characteristics*, for typical values.

Table 2. Pin Characteristics

Symbol	Parameter	Test Conditions	Minimum	Typical	Maximum	Units
C_{IN}	Input Capacitance			2		pF
$R_{PULLDOWN}$	Input Pulldown Resistor			51		$k\Omega$
R_{PULLUP}	Input Pullup Resistor			51		$k\Omega$

Function Table

Table 3. SEL Input Selection Function Table

Input	Operation
SEL	
0	PCLK0, nPCLK0 is the selected differential clock input.
1	PCLK1, nPCLK1 is the selected differential clock input.
Open (default)	Input buffers are disabled and outputs are static.

NOTE: SEL is an asynchronous control.

Absolute Maximum Ratings

Exposure to absolute maximum rating conditions for extended periods may affect product reliability. Stresses beyond those listed under *Absolute Maximum Ratings* may cause permanent damage to the device. These ratings are stress specifications only. Functional operation of product at these conditions or any conditions beyond those listed in the *DC Characteristics or AC Characteristics* is not implied.

Item	Rating
Supply Voltage, V_{DD}	4.6V
Inputs, V_I	-0.5V to $V_{DD} + 0.5V$
Outputs, I_O Continuous Current Surge Current	10mA 15mA
V_{REF} current Sink/Source, I_{REF}	$\pm 2mA$
Maximum Junction Temperature, $T_{J,MAX}$	150°C
Storage Temperature, T_{STG}	-65°C to 150°C
ESD - Human Body Model, NOTE 1	2000V
ESD - Charged Device Model, NOTE 1	1500V

NOTE 1: According to JEDEC/JESD JS-001-2012/22-C101E.

Recommended Operating Conditions

Symbol	Parameter	Minimum	Typical	Maximum	Units
T_A	Ambient air temperature	-40		85	°C
T_J	Junction temperature			125	°C

NOTE 1: It is the user's responsibility to ensure that device junction temperature remains below the maximum allowed.

NOTE 2: All conditions in the table must be met to guarantee device functionality.

NOTE 3: The device is verified to the maximum operating junction temperature through simulation.

Electrical Characteristics

Table 4A. Power Supply Characteristics, $V_{DD} = 2.5V \pm 5\%$, $T_A = -40^\circ C$ to $85^\circ C$

Symbol	Parameter	Test Conditions	Minimum	Typical	Maximum	Units
V_{DD}	Power Supply Voltage		2.375	2.5	2.625	V
I_{DD}	Power Supply Current	SEL = 0 or 1; $f_{REF} = 100MHz$; Q0 to Q3 terminated 100Ω between nQx, Qx		84	100	mA
		SEL = 0 or 1; $f_{REF} = 800MHz$; Q0 to Q3 terminated 100Ω between nQx, Qx		84	100	mA
		SEL = 0 or 1; $f_{REF} = 2GHz$; Q0 to Q3 terminated 100Ω between nQx, Qx		84	100	mA

Table 4B. LVCMOS/LVTTL DC Characteristics, $V_{DD} = 2.5V \pm 5\%$, $T_A = -40^{\circ}C$ to $85^{\circ}C$

Symbol	Parameter		Test Conditions	Minimum	Typical	Maximum	Units
V_{dI3}	Open-Pin Voltage (Default State)	SEL	Open		$V_{DD} / 2$		V
V_{IH}	Input High Voltage	SEL		$0.7 * V_{DD}$		$V_{DD} + 0.3$	V
V_{IL}	Input Low Voltage	SEL		-0.3		$0.2 * V_{DD}$	V
I_{IH}	Input High Current	SEL	$V_{DD} = V_{IN} = 2.625V$			150	μA
I_{IL}	Input Low Current	SEL	$V_{DD} = 2.625V, V_{IN} = 0V$	-150			μA

Table 4C. Differential Input DC Characteristics, $V_{DD} = 2.5V \pm 5\%$, $T_A = -40^{\circ}C$ to $85^{\circ}C$

Symbol	Parameter		Test Conditions	Minimum	Typical	Maximum	Units
I_{IH}	Input High Current	PCLK0, nPCLK1 PCLK1, nPCLK1	$V_{DD} = V_{IN} = 2.625V$			150	μA
I_{IL}	Input Low Current	PCLK0, PCLK1	$V_{DD} = 2.625V, V_{IN} = 0V$	-10			μA
		nPCLK0, nPCLK1	$V_{DD} = 2.625V, V_{IN} = 0V$	-150			μA
V_{REF}	Reference Voltage for Input Bias		$I_{REF} = \pm 1mA$	$V_{DD} - 1.50$	$V_{DD} - 1.35$	$V_{DD} - 1.15$	V
V_{PP}	Peak-to-Peak Voltage; NOTE 1		$f_{REF} < 1.5 GHz$	0.1		1.5	V
			$f_{REF} \geq 1.5 GHz$	0.2		1.5	V
V_{CMR}	Common Mode Input Voltage; NOTE 1, 2			1.0		$V_{DD} - 0.6$	V

NOTE 1: V_{IL} should not be less than -0.3V.

NOTE 2: Common mode input voltage is defined at the crosspoint.

Table 4D. LVDS DC Characteristics, $V_{DD} = 2.5V \pm 5\%$, $T_A = -40^{\circ}C$ to $85^{\circ}C$

Symbol	Parameter	Test Conditions	Minimum	Typical	Maximum	Units
V_{OD}	Differential Output Voltage		250		450	mV
ΔV_{OD}	V_{OD} Magnitude Change				50	mV
V_{OS}	Offset Voltage		1.15		1.45	V
ΔV_{OS}	V_{OS} Magnitude Change				50	mV

AC Electrical Characteristics

Table 5. AC Electrical Characteristics, $V_{DD} = 2.5V \pm 5\%$, $T_A = -40^\circ C$ to $85^\circ C$

Symbol	Parameter		Test Conditions	Minimum	Typical	Maximum	Units
f_{REF}	Input Frequency	PCLK[0:1], nPCLK[0:1]				2	GHz
$\Delta V/\Delta t$	Input Edge Rate	PCLK[0:1], nPCLK[0:1]		1.5			V/ns
t_{PD}	Propagation Delay; NOTE 1		PCLK[0:1], nPCLK[0:1] to any Qx, nQx for $V_{PP} = 0.1V$ or $0.3V$	120	210	300	ps
$t_{sk(o)}$	Output Skew; NOTE 2, 3					20	ps
$t_{sk(i)}$	Input Skew; NOTE 3					20	ps
$t_{sk(p)}$	Pulse Skew		$f_{REF} = 100MHz$			15	ps
$t_{sk(pp)}$	Part-to-Part Skew; NOTE 3, 4					230	ps
t_{JIT}	Buffer Additive Phase Jitter, RMS; refer to Additive Phase Jitter Section		$f_{REF} = 122.88MHz$ Square Wave, $V_{PP} = 1V$, Integration Range: 1kHz – 40MHz		138	205	fs
			$f_{REF} = 122.88MHz$ Square Wave, $V_{PP} = 1V$, Integration Range: 10kHz – 20MHz		92	135	fs
			$f_{REF} = 122.88MHz$ Square Wave, $V_{PP} = 1V$, Integration Range: 12kHz – 20MHz		92	135	fs
			$f_{REF} = 156.25MHz$ Square Wave, $V_{PP} = 1V$, Integration Range: 1kHz – 40MHz		89	130	fs
			$f_{REF} = 156.25MHz$ Square Wave, $V_{PP} = 1V$, Integration Range: 10kHz – 20MHz		65	95	fs
			$f_{REF} = 156.25MHz$ Square Wave, $V_{PP} = 1V$, Integration Range: 12kHz – 20MHz		65	95	fs
			$f_{REF} = 156.25MHz$ Square Wave, $V_{PP} = 0.5V$, Integration Range: 1kHz – 40MHz		87	130	fs
			$f_{REF} = 156.25MHz$ Square Wave, $V_{PP} = 0.5V$, Integration Range: 10kHz – 20MHz		64	95	fs
			$f_{REF} = 156.25MHz$ Square Wave, $V_{PP} = 0.5V$, Integration Range: 12kHz – 20MHz		64	95	fs
t_R / t_F	Output Rise/ Fall Time		20% to 80% outputs loaded with 100 Ω	40		250	ps
$MUX_{ISOLATION}$	Mux Isolation; NOTE 5		$f_{REF} = 100MHz$		72		dB

NOTE: Electrical parameters are guaranteed over the specified ambient operating temperature range, which is established when the device is mounted in a test socket with maintained transverse airflow greater than 500 lfm. The device will meet specifications after thermal equilibrium has been reached under these conditions.

NOTE 1: Measured from the differential input crosspoint to the differential output crosspoint.

NOTE 2: Defined as skew between outputs at the same supply voltage and with equal load conditions. Measured at the differential crosspoint.

NOTE 3: This parameter is defined in accordance with JEDEC Standard 65.

NOTE 4: Defined as skew between outputs on different devices operating at the same supply voltage, same frequency, same temperature and with equal load conditions. Using the same type of inputs on each device, the outputs are measured at the differential crosspoint.

NOTE 5: Qx, nQx outputs measured differentially. See *MUX Isolation diagram* in the *Parameter Measurement Information section*.

Additive Phase Jitter

The spectral purity in a band at a specific offset from the fundamental compared to the power of the fundamental is called the **dBc Phase Noise**. This value is normally expressed using a Phase noise plot and is most often the specified plot in many applications. Phase noise is defined as the ratio of the noise power present in a 1Hz band at a specified offset from the fundamental frequency to the power value of the fundamental. This ratio is expressed in decibels (dBm) or a ratio

of the power in the 1Hz band to the power in the fundamental. When the required offset is specified, the phase noise is called a **dBc** value, which simply means dBm at a specified offset from the fundamental. By investigating jitter in the frequency domain, we get a better understanding of its effects on the desired application over the entire time record of the signal. It is mathematically possible to calculate an expected bit error rate given a phase noise plot.

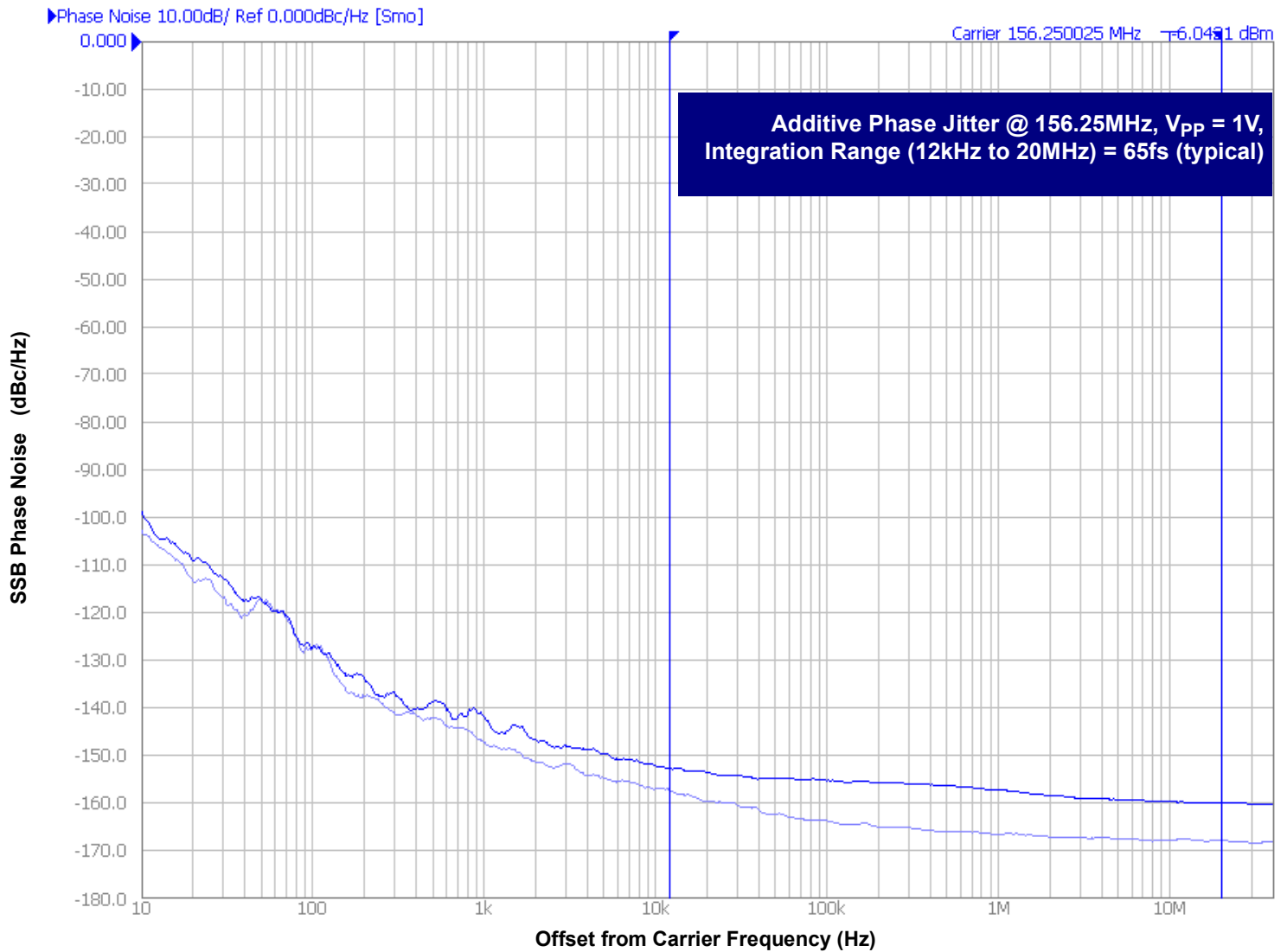

As with most timing specifications, phase noise measurements have issues relating to the limitations of the measurement equipment. The noise floor of the equipment can be higher or lower than the noise floor of the device. Additive phase noise is dependent on both the noise floor of the input source and measurement equipment.

Measured using a Wenzel 156.25MHz Oscillator as the input source.

Parameter Measurement Information

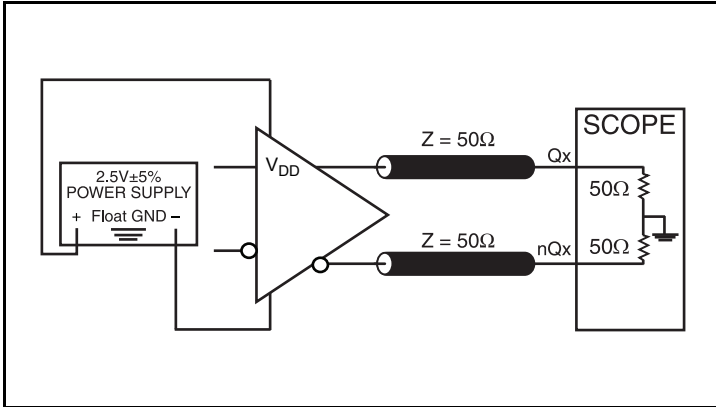

LVDS Output Load Test Circuit

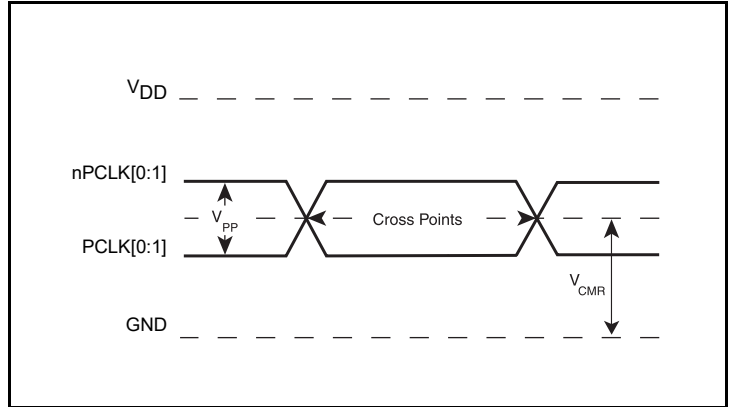

Differential Input Level

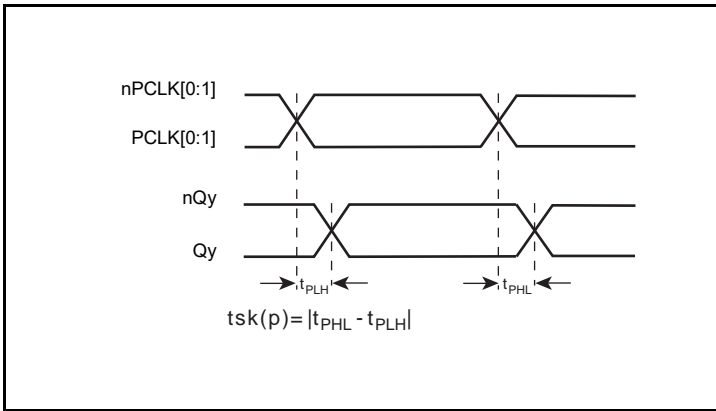

Pulse Skew

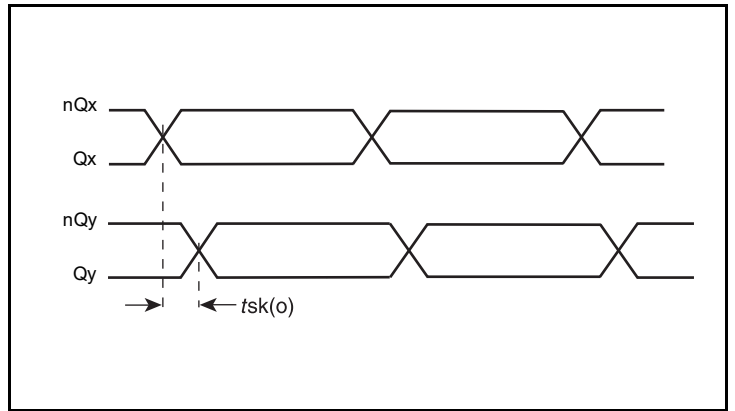

Output Skew

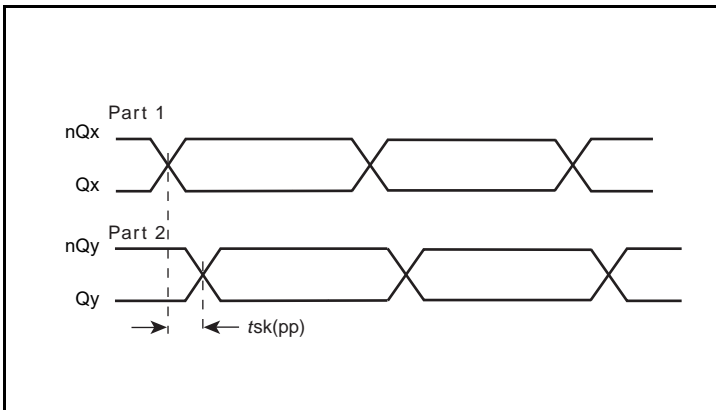

Part-to-Part Skew

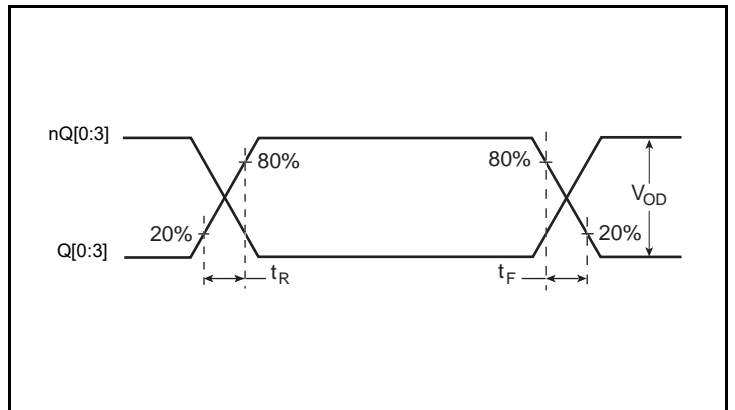

Output Rise/Fall Time

Parameter Measurement Information, continued

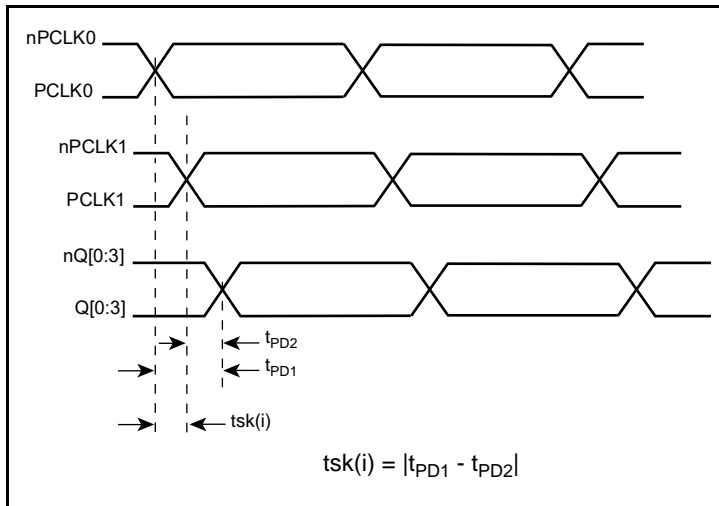

Input Skew

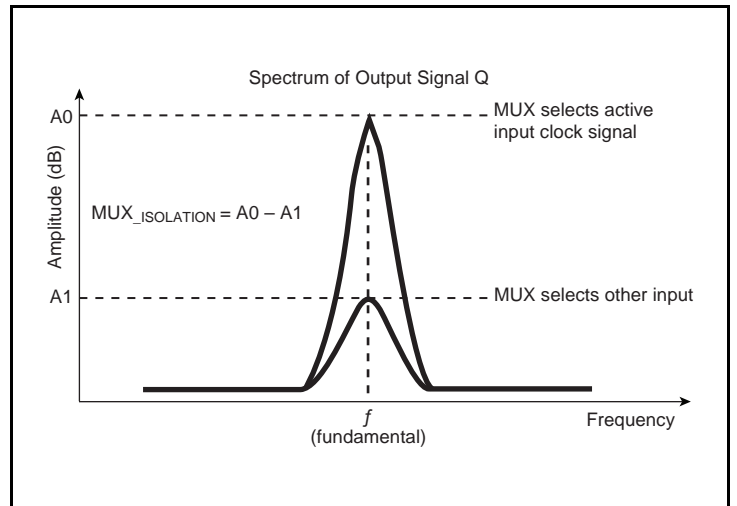

MUX Isolation

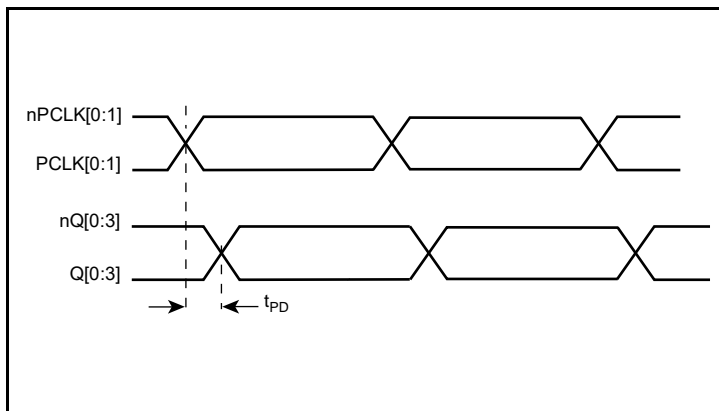

Propagation Delay

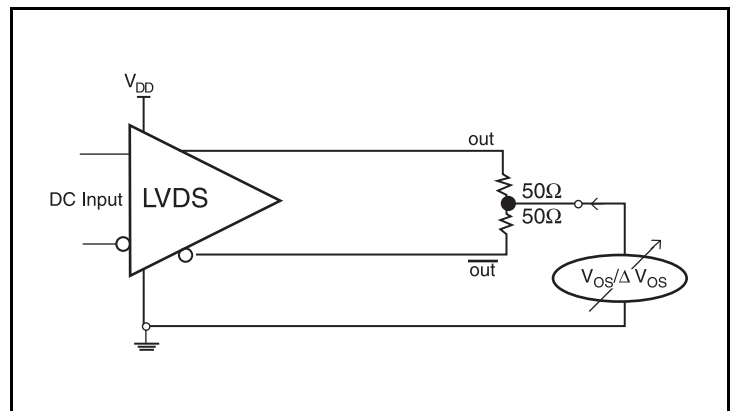

Offset Voltage Setup

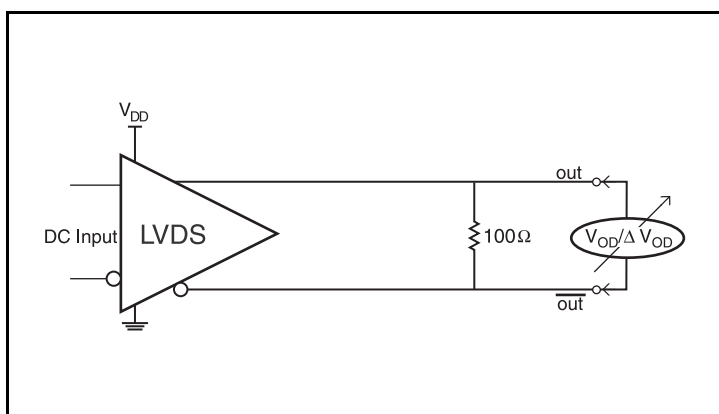

Differential Output Voltage Setup

Applications Information

Recommendations for Unused Input and Output Pins

Inputs:

PCLK/nPCLK Inputs

For applications not requiring the use of a differential input, both the PCLK and nPCLK pins can be left floating. Though not required, but for additional protection, a 1kΩ resistor can be tied from PCLK to ground.

Outputs:

LVDS Outputs

All unused LVDS output pairs can be either left floating or terminated with 100Ω across. If they are left floating, there should be no trace attached.

Wiring the Differential Input to Accept Single-Ended Levels

Figure 1 shows how a differential input can be wired to accept single ended levels. The reference voltage $V1 = V_{DD}/2$ is generated by the bias resistors R1 and R2. The bypass capacitor (C1) is used to help filter noise on the DC bias. This bias circuit should be located as close to the input pin as possible. The ratio of R1 and R2 might need to be adjusted to position the V1 in the center of the input voltage swing. For example, if the input clock swing is 2.5V and $V_{DD} = 2.5V$, R1 and R2 value should be adjusted to set V1 at 1.25V. The values below are for when both the single ended swing and V_{DD} are at the same voltage. This configuration requires that the sum of the output impedance of the driver (R_o) and the series resistance (R_s) equals the transmission line impedance. In addition, matched termination at the input will attenuate the signal in half. This can be done in one of two ways. First, R3 and R4 in parallel should equal the transmission

line impedance. For most 50Ω applications, R3 and R4 can be 100Ω. The values of the resistors can be increased to reduce the loading for slower and weaker LVCMOS driver. When using single-ended signaling, the noise rejection benefits of differential signaling are reduced. Even though the differential input can handle full rail LVCMOS signaling, it is recommended that the amplitude be reduced. The datasheet specifies a lower differential amplitude, however this only applies to differential signals. For single-ended applications, the swing can be larger, however V_{IL} cannot be less than -0.3V and V_{IH} cannot be more than $V_{DD} + 0.3V$. Though some of the recommended components might not be used, the pads should be placed in the layout. They can be utilized for debugging purposes. The datasheet specifications are characterized and guaranteed by using a differential signal.

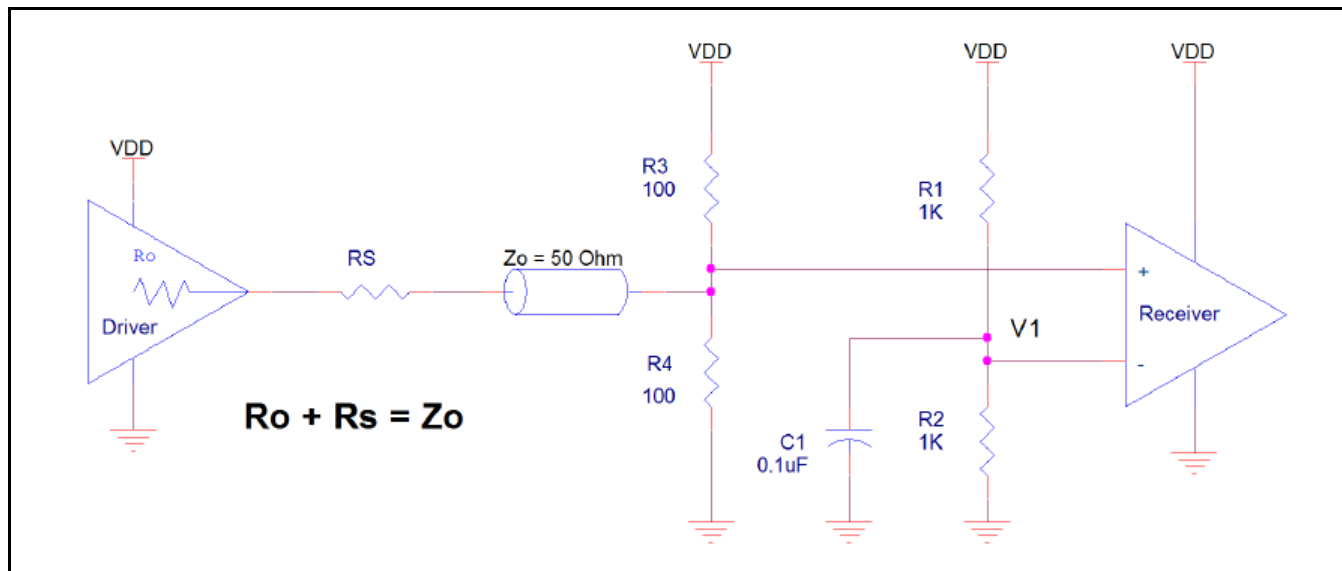

Figure 1. Recommended Schematic for Wiring a Differential Input to Accept Single-ended Levels

2.5V LVPECL Clock Input Interface

The PCLK /nPCLK accepts LVPECL, LVDS, and other differential signals. Both signals must meet the V_{PP} and V_{CMR} input requirements. *Figures 2A to 2C* show interface examples for the PCLK/ nPCLK input driven by the most common driver types. The

input interfaces suggested here are examples only. If the driver is from another vendor, use their termination recommendation. Please consult with the vendor of the driver component to confirm the driver termination requirements.

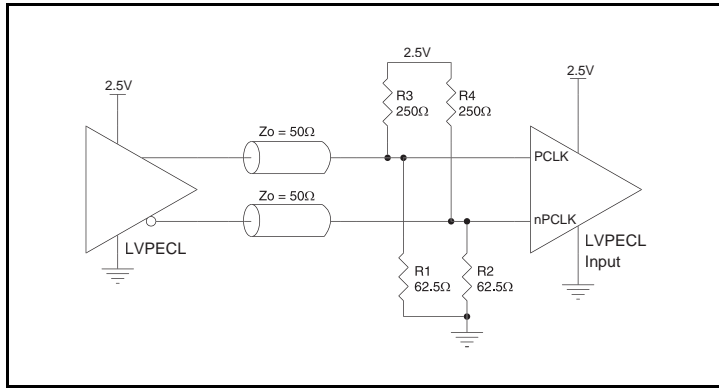

Figure 2A. PCLK/nPCLK Input Driven by a 2.5V LVPECL Driver

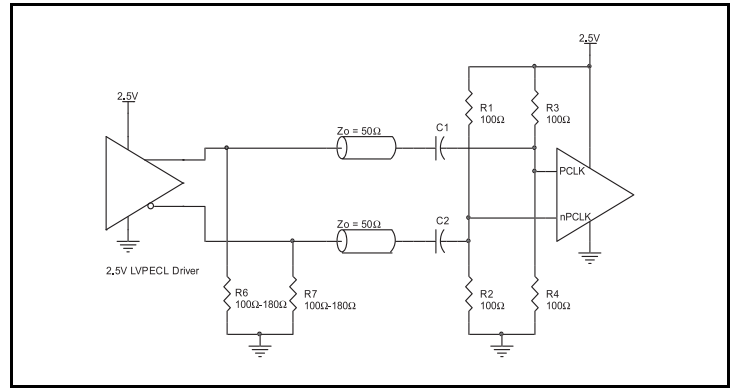

Figure 2B. PCLK/nPCLK Input Driven by a 2.5V LVPECL Driver with AC Couple

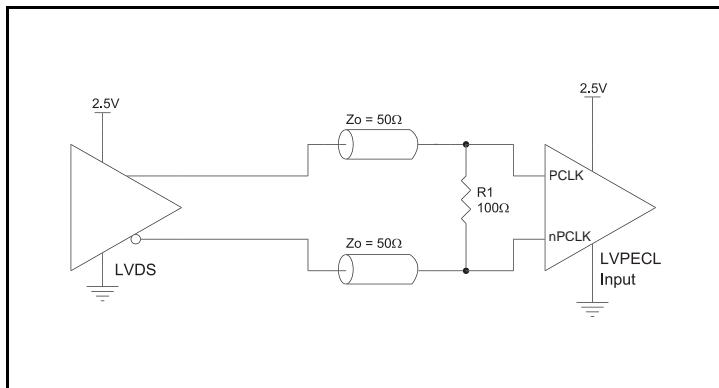
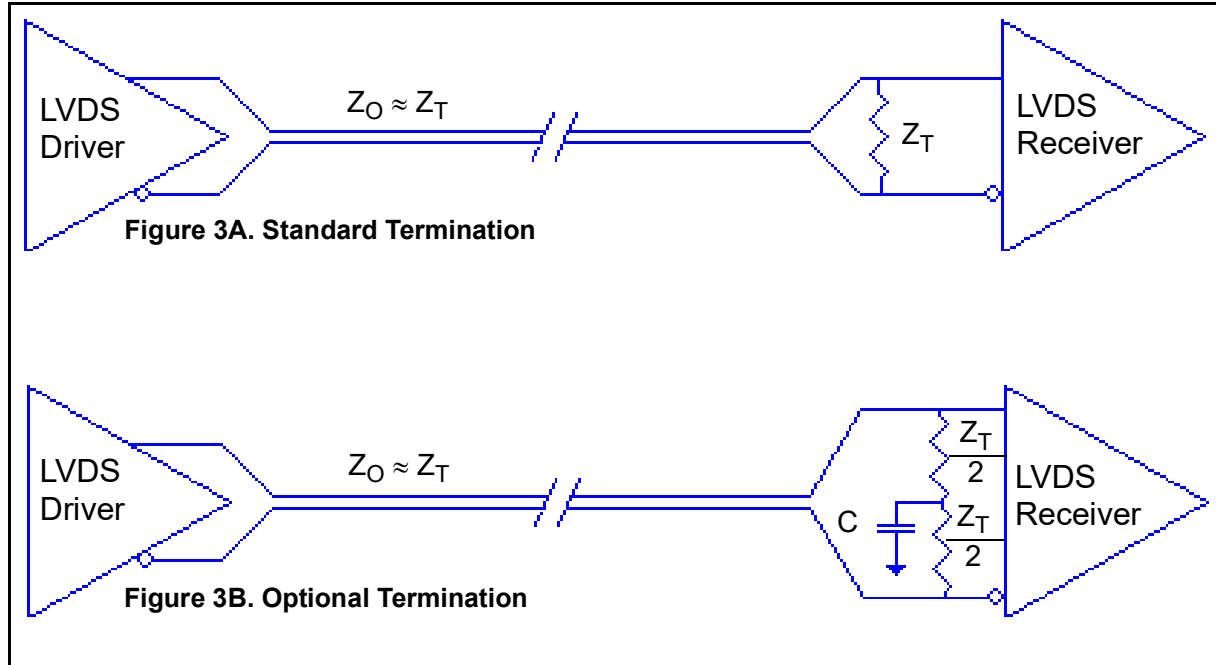

Figure 2C. PCLK/nPCLK Input Driven by a 2.5V LVDS Driver

LVDS Driver Termination

For a general LVDS interface, the recommended value for the termination impedance (Z_T) is between 90Ω and 132Ω . The actual value should be selected to match the differential impedance (Z_0) of your transmission line. A typical point-to-point LVDS design uses a 100Ω parallel resistor at the receiver and a 100Ω differential transmission-line environment. In order to avoid any transmission-line reflection issues, the components should be surface mounted and must be placed as close to the receiver as possible. Renesas offers a full line of LVDS compliant devices with two types of output structures: current source and voltage source.

The standard termination schematic as shown in *Figure 3A* can be used with either type of output structure. *Figure 3B*, which can also be used with both output types, is an optional termination with center tap capacitance to help filter common mode noise. The capacitor value should be approximately 50pF . If using a non-standard termination, it is recommended to contact Renesas and confirm if the output structure is current source or voltage source type. In addition, since these outputs are LVDS compatible, the input receiver's amplitude and common-mode input range should be verified for compatibility with the output.



LVDS Termination

VFQFPN EPAD Thermal Release Path

In order to maximize both the removal of heat from the package and the electrical performance, a land pattern must be incorporated on the Printed Circuit Board (PCB) within the footprint of the package corresponding to the exposed metal pad or exposed heat slug on the package, as shown in *Figure 4*. The solderable area on the PCB, as defined by the solder mask, should be at least the same size/shape as the exposed pad/slug area on the package to maximize the thermal/electrical performance. Sufficient clearance should be designed on the PCB between the outer edges of the land pattern and the inner edges of pad pattern for the leads to avoid any shorts.

While the land pattern on the PCB provides a means of heat transfer and electrical grounding from the package to the board through a solder joint, thermal vias are necessary to effectively conduct from the surface of the PCB to the ground plane(s). The land pattern must be connected to ground through these vias. The vias act as “heat pipes”. The number of vias (i.e. “heat pipes”) are application specific

and dependent upon the package power dissipation as well as electrical conductivity requirements. Thus, thermal and electrical analysis and/or testing are recommended to determine the minimum number needed. Maximum thermal and electrical performance is achieved when an array of vias is incorporated in the land pattern. It is recommended to use as many vias connected to ground as possible. It is also recommended that the via diameter should be 12 to 13mils (0.30 to 0.33mm) with 1oz copper via barrel plating. This is desirable to avoid any solder wicking inside the via during the soldering process which may result in voids in solder between the exposed pad/slug and the thermal land. Precautions should be taken to eliminate any solder voids between the exposed heat slug and the land pattern. Note: These recommendations are to be used as a guideline only. For further information, please refer to the Application Note on the Surface Mount Assembly of Amkor’s Thermally/Electrically Enhance Leadframe Base Package, Amkor Technology.

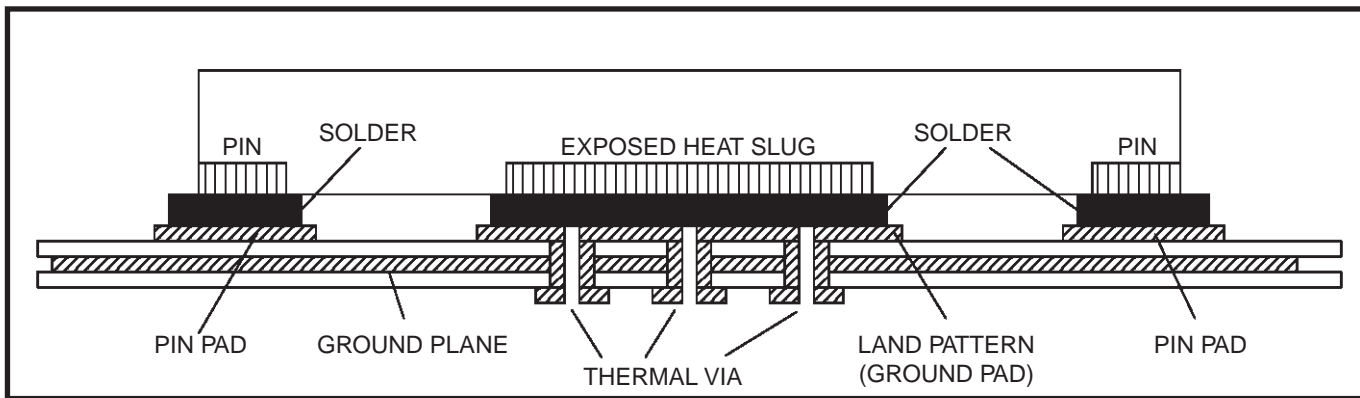

Figure 4. P.C. Assembly for Exposed Pad Thermal Release Path – Side View (drawing not to scale)

Power Considerations

This section provides information on power dissipation and junction temperature for the 8SLVD1204. Equations and example calculations are also provided.

1. Power Dissipation.

The total power dissipation for the 8SLVD1204 is the sum of the core power plus the output power dissipation due to the load. The following is the power dissipation for $V_{DD} = 2.5V + 5\% = 2.625V$, which gives worst case results.

- Total Power $_{(core)MAX} = V_{DD_MAX} * I_{DD_MAX} = 2.625V * 100mA = \mathbf{262.5mW}$

2. Junction Temperature.

Junction temperature, T_j , is the temperature at the junction of the bond wire and bond pad directly affects the reliability of the device. The maximum recommended junction temperature is 125°C. Limiting the internal transistor junction temperature, T_j , to 125°C ensures that the bond wire and bond pad temperature remains below 125°C.

The equation for T_j is as follows: $T_j = \theta_{JA} * Pd_total + T_A$

T_j = Junction Temperature

θ_{JA} = Junction-to-Ambient Thermal Resistance

Pd_total = Total Device Power Dissipation (example calculation is in section 1 above)

T_A = Ambient Temperature

In order to calculate junction temperature, the appropriate junction-to-ambient thermal resistance θ_{JA} must be used. Assuming no air flow and a multi-layer board, the appropriate value is 74.7°C/W per Table 6 below.

Therefore, T_j for an ambient temperature of 85°C with all outputs switching is:

$$85^\circ\text{C} + 0.263\text{W} * 74.7^\circ\text{C/W} = 104.6^\circ\text{C}. \text{ This is below the limit of } 125^\circ\text{C}.$$

This calculation is only an example. T_j will obviously vary depending on the number of loaded outputs, supply voltage, air flow and the type of board (multi-layer).

Table 6. Thermal Resistance θ_{JA} for 16-Lead VFQFPN, Forced Convection

θ_{JA} at 0 Air Flow			
Meters per Second	0	1	2.5
Multi-Layer PCB, JEDEC Standard Test Boards	74.7°C/W	65.3°C/W	58.5°C/W

Case Temperature Considerations

This device supports applications in a natural convection environment which does not have any thermal conductivity through ambient air. The printed circuit board (PCB) is typically in a sealed enclosure without any natural or forced air flow and is kept at or below a specific temperature. The device package design incorporates an exposed pad (ePad) with enhanced thermal parameters which is soldered to the PCB where most of the heat escapes from the bottom exposed pad. For this type of application, it is recommended to use the junction-to-board thermal characterization parameter Ψ_{JB} (Psi-JB) to calculate the junction temperature (T_J) and ensure it does not exceed the maximum allowed junction temperature in [Absolute Maximum Ratings](#).

The junction-to-board thermal characterization parameter, Ψ_{JB} , is calculated using the following equation:

$$T_J = T_{CB} + \Psi_{JB} \times P_d, \text{ where}$$

T_J = Junction temperature at steady state condition in ($^{\circ}\text{C}$).

T_{CB} = Case temperature (Bottom) at steady state condition in ($^{\circ}\text{C}$).

Ψ_{JB} = Thermal characterization parameter to report the difference between junction temperature and the temperature of the board measured at the top surface of the board.

P_d = Power dissipation (W) in desired operating configuration.

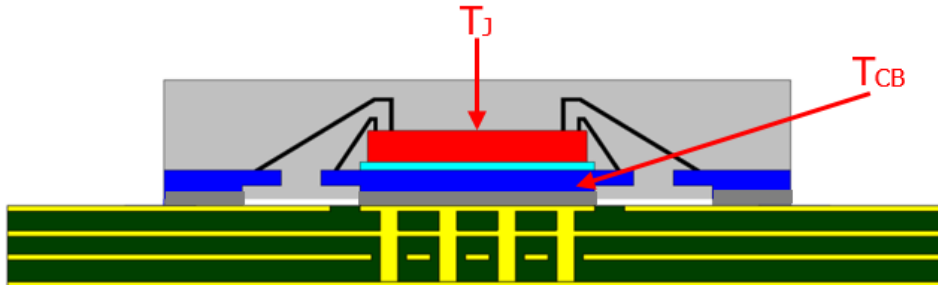

The ePad provides a low thermal resistance path for heat transfer to the PCB and represents the key pathway to transfer heat away from the IC to the PCB. Its critical that the connection of the exposed pad to the PCB is properly constructed to maintain the desired IC case temperature (T_{CB}). A good connection ensures that temperature at the exposed pad (T_{CB}) and the board temperature (T_B) are relatively the same. An improper connection can lead to increased junction temperature, increased power consumption, and decreased electrical performance. In addition, there could be long-term reliability issues and increased failure rate.

Example calculation for junction temperature (T_J): $T_J = T_{CB} + \Psi_{JB} \times P_d$

Package type:	16-Lead VFQFN
Ψ_{JB}	1.0 C/W
T_{CB}	105 $^{\circ}\text{C}$
P_d	0.263 W

For the variables above, the junction temperature is equal to 105.3 $^{\circ}\text{C}$. Since this is below the maximum junction temperature of 125 $^{\circ}\text{C}$, there are no long-term reliability concerns. In addition, since the junction temperature at which the device was characterized using forced convection is 104.6 $^{\circ}\text{C}$, this device can function without the degradation of the specified AC or DC parameters.

Reliability Information

Table 7. θ_{JA} vs. Air Flow Table for a 16-Lead VFQFPN

θ_{JA} at 0 Air Flow			
Meters per Second	0	1	2.5
Multi-Layer PCB, JEDEC Standard Test Boards	74.7°C/W	65.3°C/W	58.5°C/W

Transistor Count

The transistor count for the 8SLVD1204 is: 417

Package Outline Drawings

The package outline drawings are located at the end of this document and are accessible from the Renesas website (see Ordering Information for POD links). The package information is the most current data available and is subject to change without revision of this document.

Ordering Information

Table 8. Ordering Information

Part/Order Number	Marking	Package	Shipping Packaging	Temperature
8SLVD1204NLGI	1204I	3.0 × 3.0 × 0.9 mm 16-VFQFPN	Tray	-40°C to 85°C
8SLVD1204NLGI8	1204I	3.0 × 3.0 × 0.9 mm 16-VFQFPN	Tape & Reel, pin 1 orientation: EIA-481-C	-40°C to 85°C
8SLVD1204NLGI/W	1204I	3.0 × 3.0 × 0.9 mm 16-VFQFPN	Tape & Reel, pin 1 orientation: EIA-481-D	-40°C to 85°C

Table 9. Pin 1 Orientation in Tape and Reel Packaging

Part Number Suffix	Pin 1 Orientation	Illustration
8	Quadrant 1 (EIA-481-C)	
/W	Quadrant 2 (EIA-481-D)	

Revision History

Revision Date	Description of Change
May 11, 2021	<ul style="list-style-type: none"> Updated shipping packaging for 8SLVD1204NLGI from "Tube" to "Tray". Updated Package Outline Drawings section; added POD link to ordering information.
May 8, 2020	<ul style="list-style-type: none"> Added Case Temperature Considerations
November 29, 2018	<ul style="list-style-type: none"> Updated the description of Absolute Maximum Ratings Added Recommended Operating Conditions Updated the description of Package Outline Drawings
January 21, 2018	<ul style="list-style-type: none"> Updated the package outline drawings; however, no technical changes. Replaced the package term VFQFN with VFQFPN.
July 8, 2014	Corrected part number
February 26, 2014	Ordering Info: Changed Tray to Tube.

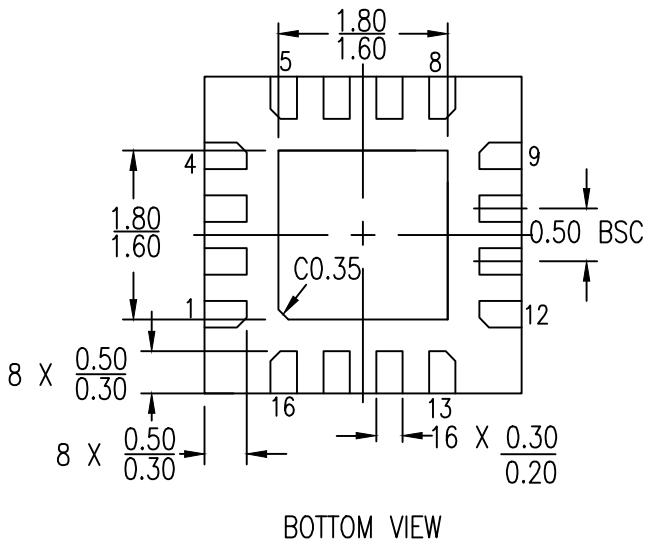
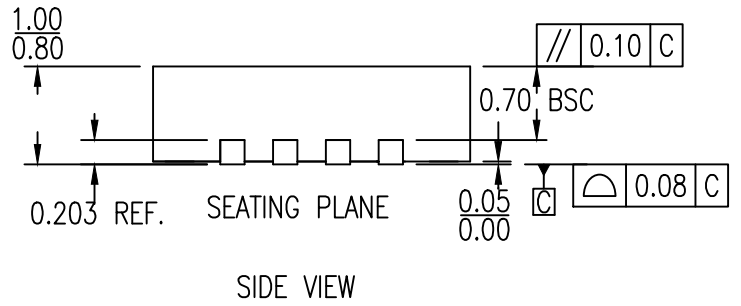
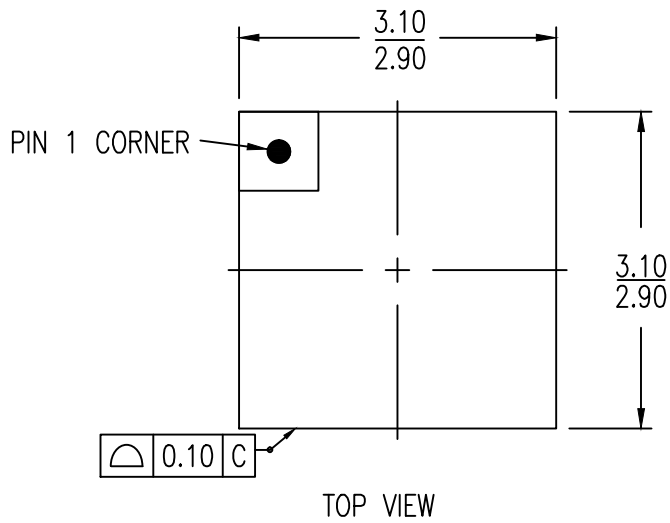

NOTES:
1. ALL DIMENSIONS ARE IN mm. ANGLES IN DEGREES

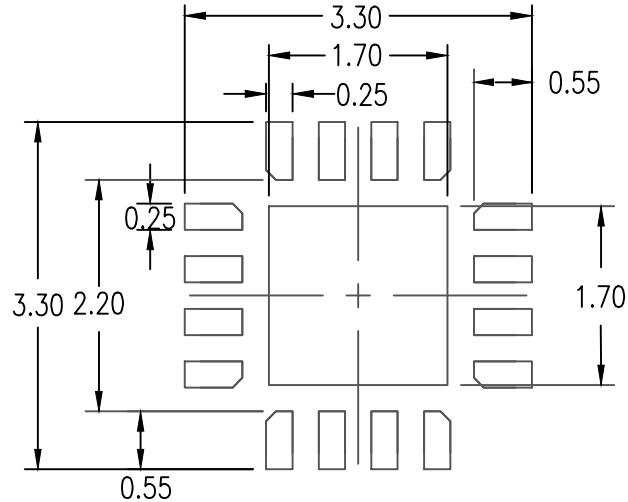

RECOMMENDED LAND PATTERN DIMENSION

NOTES:

1. ALL DIMENSIONS ARE IN mm. ANGLES IN DEGREES
2. TOP DOWN VIEW-AS VIEWED ON PCB
3. LAND PATTERN RECOMMENDATION IS PER IPC-7351B GENERIC REQUIREMENT FOR SURFACE MOUNT DESIGN AND LAND PATTERN

Package Revision History		
Date Created	Rev No.	Description
Oct 25, 2017	Rev 04	Remove Bookmak at Pdf Format & Update Thickness Tolerance
Jan 18, 2018	Rev 05	Change QFN to VFQFPN